



## CHAPTER OVERVIEW

---

**Operating Instructions** .....

**A**

.....

**B**

**Spare Parts Lists** .....

**C**

.....

**D**

**Attachment** .....

**E**

### Manufacturer in terms of 2014/68/EU

The full name and address of the manufacturer is:

Lenhardt & Wagner GmbH

An der Tuchbleiche 39

68623 Hüttenfeld / Germany

Phone: +49 (0) 62 56 - 85 88 0 - 0

Fax: +49 (0) 62 56 - 85 88 0 - 14

E-Mail: [service@lw-compressors.com](mailto:service@lw-compressors.com)

Internet: [www.lw-compressors.com](http://www.lw-compressors.com)



---



## SERVICE INFORMATION / WARRANTY

---

### Compressor information

\_\_\_\_\_

Type designation

\_\_\_\_\_

Serial number

\_\_\_\_\_

Date of construction

### Purchase information

\_\_\_\_\_

Purchase date

\_\_\_\_\_

First commissioned on

\_\_\_\_\_

Warranty period

\_\_\_\_\_

Dealer's stamp

### Warranty

L&W will uphold warranty claims made during a period of 12 months from the invoice date.

If the compressor was purchased from an official L&W dealer, the date on the dealer's invoice is valid. Warranty claims can only be made on presentation of the original invoice.

Should verifiably defective parts have been delivered, we will decide to either replace the parts or repair them. The resulting transport and assembly costs will be invoiced.

No reduction of the purchase price or changes to the contract can be made. The parts for which a claim is being made should be kept safe by the purchaser and, when requested, sent to us at their cost. Replaced parts become the property of L&W. If maintenance work is carried out without our knowledge or permission by the purchaser or a third party, we are absolved from any liability for warranty claims. As a matter of principle, warranty claims can only be made by the initial purchaser.

---



A

# Operating Instructions

Breathing Air Compressor

LW SC-600 E / LW SC-680 E / LW SC-750 E





## TABLE OF CONTENTS

---

### **General Information and Technical Data**

General Information / Description of Warning Symbols .....	4
Scope of Delivery .....	5
Technical Data .....	6
Unit Assembly .....	7
Switchboard .....	8
Flow chart .....	9

### **Safety Precautions**

Intended Use / Operators .....	11
Safety instructions on the unit .....	12
General Safety Precautions .....	13
Unit customised safety notices .....	14
Maintenance instructions .....	15
Transportation instructions / Safety regulations .....	16

### **Installation**

Installation in closed rooms .....	18
Dimensions .....	19
Minimum distances .....	20
Ventilation .....	21
Electrical Installation .....	22 - 23

### **Operation**

Important operation instructions .....	25
First commissioning .....	26 - 28
Daily commissioning .....	29
Filling procedure .....	30
Switch off the compressor .....	31

<b>Remedying faults</b> .....	32 - 36
-------------------------------	---------

### **Maintenance and Service**

Service, Repair and Maintenance .....	38
Maintenance Lists / Maintenance Intervals .....	39 - 42
Check V-belt tension / Tension V-belt .....	43
Compressor lubrication / Check oil level .....	44
Oil change .....	45
Oil sieve change .....	46
Final pressure switch .....	47

A



## TABLE OF CONTENTS

---

### **Maintenance and Service**

Automatic condensation dump system .....	48
Oil / water separators 1st, 2nd and 3rd stage - maintenance .....	49
Oil / water separator final stage - maintenance .....	50
Pneumatic condensate valve - maintenance .....	51
Filter housing / Filter cartridge .....	52
Filter cartridge change .....	53
Filter housing - Maintenance .....	54
Inlet filters / Inlet filter cartridge change .....	55
Cylinder heads and valves .....	56
Replace inlet and outlet valves 1st and 2nd stage .....	57 - 58
Replace inlet and outlet valves 3rd and 4th stage .....	59
Safety valves .....	60
Pressure maintaining / non return valve .....	61
Safety valve test .....	62
Leak test .....	63
Pressure gas vessel test .....	64

### **Maintenance records and Storage**

Maintenance records .....	66 - 70
Conservation / storage of the compressor / De-conservation, commissioning .....	71
Transportation instructions / Disposal .....	72

A

## GENERAL INFORMATION

---

### General Information

We strongly recommend reading this manual thoroughly prior to operation and follow all the safety precautions precisely. Damage resulting from any deviation from these instructions is excluded from warranty and liability for this product. Carry out other commissioning steps only if you have fully understood the following contents.

Before commissioning and using the unit, carry out all the essential preliminary work and measures concerning legal regulations and safety. These are described on the following pages of this operation manual.

A

### Description of marks and warning signs

The following warning signs are used in this document to identify the corresponding warning notes which require particular attention by the user. The warning signs are defined as follows:



#### Caution

Indicates an imminently hazardous situation which, if not avoided, could result in serious injury, physical injury or death.



#### Warning

Indicates a potentially hazardous situation which, if not avoided, could result in physical injury or damage to the product or environment.



#### Note

Indicates additional information on how to use the unit.



## DESCRIPTION

---

### Scope of Delivery

Compressors are provided in different equipped versions.

A

### Versions

#### Filling pressure versions:

- PN 225 bar
- PN 330 bar
- PN 225 / 330 bar

### Specifications

- Automatic condensate drain
- Automatic stop at final pressure
- Hour counter
- Operating panel c/w start/stop and condensate test buttons, as well as emergency stop switch
- 4x Filling hose c/w filling valve
- Motor protection switch
- Safety switch
- Pressure maintaining and non return valve
- All pistons c/w steel piston rings
- Low pressure oil pump and filter
- Oil- / Water separators in stainless steel
- Safety valves after each stage
- 4 concentric suction/pressure valves

### Options

- Auto start system
- 200 and 300 bar parallel filling pressures
- Oil pressure gauge
- Intermediate pressure gauges
- Oil pressure monitoring c/w auto shut down
- Cylinder head temperature monitoring with auto shut down
- Oil temperature display with auto shut down
- Puracon filter monitoring (Auto shut down also available)
- ECC control in remote control box
- Phase monitoring c/w shut down at wrong direction of rotation
- Additional high pressure outlet
- Power cable and plug
- Block heating device
- 420 bar Version

## DESCRIPTION

### Technical Data



A

Technical Data	LW SC-600 E	LW SC-680 E	LW SC-750 E
Charging Rate [l/min]:	600	680	750
Max. Operating Pressure [bar]:	350	350	350
RPM [min <sup>-1</sup> ]:	940	1060	1170
Number of Pressure Stages:	4	4	4
Cylinder Bore 1st Stage [mm]:	Ø 105	Ø 105	Ø 105
Cylinder Bore 2nd Stage [mm]:	Ø 50	Ø 50	Ø 50
Cylinder Bore 3rd Stage [mm]:	Ø 25	Ø 25	Ø 25
Cylinder Bore 4th Stage [mm]:	Ø 14	Ø 14	Ø 14
Medium:	Air / Breathing Air	Air / Breathing Air	Air / Breathing Air
Intake Pressure:	atmospheric	atmospheric	atmospheric
Oil Pressure (at operating temperature) [bar]:	+12.0(±0,1)	+12.0(±0,1)	+12.0(±0,1)
Oil Capacity [l]:	2.9	2.9	2.9
Intake Temperature [°C]:	0 < +45	0 < +45	0 < +45
Ambient Temperature [°C]:	+5 < +45	+5 < +45	+5 < +45
Cooling Air Volume [m <sup>3</sup> /h]:	> 4500	> 4500	> 4500
Standard Voltage:	400 V / 3 phase / 50 Hz	400 V / 3 phase / 50 Hz	400 V / 3 phase / 50 Hz
Protection Class Drive Motor:	IP 54	IP 54	IP 54
Drive Power [kW]:	15	15	15
RPM Motor [min <sup>-1</sup> ]:	2,890	2,890	2,890
Start:	Star/Delta	Star/Delta	Star/Delta
Noise level [dB(A)]:	83 from a distance of 1 m	83 from a distance of 1 m	83 from a distance of 1 m
Dimensions W x D x H [mm]:	1300 x 700 x 1000	1300 x 700 x 1000	1300 x 700 x 1000
Weight [kg]:	approx. 398	approx. 405	approx. 405
Content Volume Filter housing [l]:	1.7	2.3	2.3



## DESCRIPTION

### Unit Assembly

A



No.	Designation
1	Filling pressure gauge
2	Switchboard
3	Filling hoses (optional: without filling hoses)
4	Filling valves

## DESCRIPTION

### Switchboard

A



No.	Designation
1	Emergency shut-off switch
2	Hour counter
3	ON button
4	OFF button
5	Drain test button

## DESCRIPTION

A

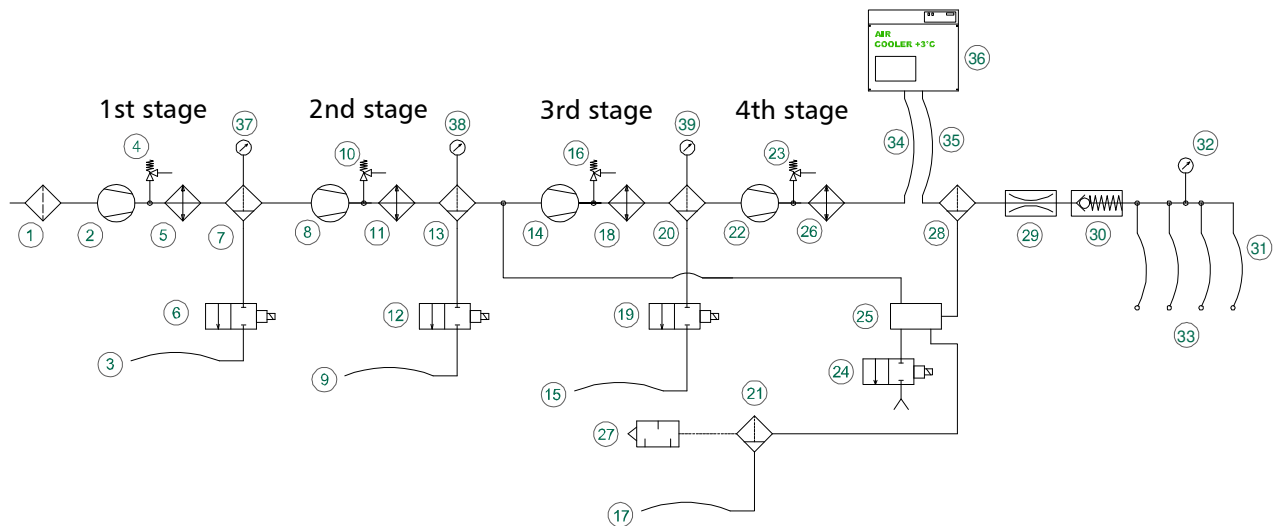

- |                                                         |                                                                    |
|---------------------------------------------------------|--------------------------------------------------------------------|
| 1. Ansaugfilter / Air Intake Filter                     | 21. Kondensatabscheider / Condensate Separator                     |
| 2. 1. Verdichterstufe / 1st Pressure Stage              | 22. 4. Verdichterstufe / 4th Pressure Stage                        |
| 3. Kondensatablaßschlauch / Condensate Release Hose     | 23. Sicherheitsventil 4. Stufe / Safety Valve 4th Stage            |
| 4. Sicherheitsventil 1. Stufe / Safety Valve 1st Stage  | 24. Kondensatventil / Condensate Valve                             |
| 5. Wärmetauscher / Heat Exchanger                       | 25. Pneumatisches Kondensatventil / Pneumatic Condensate Valve     |
| 6. Kondensatventil / Condensate Valve                   | 26. Wärmetauscher / Heat Exchanger                                 |
| 7. Öl-/Wasserabscheider / Oil-/Water Separator          | 27. Schalldämpfer Kondensatablaß / Silencer Condensate Release     |
| 8. 2. Verdichterstufe / 2nd Pressure Stage              | 28. Öl-/Wasserabscheider / Oil-/Water Separator                    |
| 9. Kondensatablaßschlauch / Condensate Release Hose     | 29. Druckhalteventil / Pressure Maintaining Valve                  |
| 10. Sicherheitsventil 2. Stufe / Safety Valve 2nd Stage | 30. Rückschlagventil / Non-Return Valve                            |
| 11. Wärmetauscher / Heat Exchanger                      | 31. Hochdruckschlauch / HP-Hose (Option on ES models)              |
| 12. Kondensatventil / Condensate Valve                  | 32. Druckmanometer (Fülldruck) / Pressure Gauge (Filling Pressure) |
| 13. Öl-/Wasserabscheider / Oil-/Water Separator         | 33. Füllanschlüsse / Filling Connection (Option on ES models)      |
| 14. 3. Verdichterstufe / 3rd Pressure Stage             | 34. Hochdruckschlauch / HP-Hose (Option)                           |
| 15. Kondensatablaßschlauch / Condensate Release Hose    | 35. Hochdruckschlauch / HP-Hose (Option)                           |
| 16. Sicherheitsventil 3. Stufe / Safety Valve 3rd Stage | 36. Air Cooler (Option)                                            |
| 17. Kondensatablaßschlauch / Condensate Release Hose    | 37. Druckmanometer (1. Stufe) / Pressure Gauge (1st Stage)         |
| 18. Wärmetauscher / Heat Exchanger                      | 38. Druckmanometer (2. Stufe) / Pressure Gauge (2nd Stage)         |
| 19. Kondensatventil / Condensate Valve                  | 39. Druckmanometer (3. Stufe) / Pressure Gauge (3rd Stage)         |
| 20. Öl-/Wasserabscheider / Oil-/Water Separator         |                                                                    |



A

# SAFETY PRECAUTIONS



## SAFETY PRECAUTIONS

---

### Intended Use

Only use the unit in perfect condition for its intended purpose, safety and intended use and observe the operating instructions! In particular disorders that may affect safety have to be eliminated immediately!

Use the unit exclusively for the determined medium (see "Technical Data"). Any other use that is not specified is not authorized. The manufacturer/supplier shall not be liable for any damages resulting from such use. Such risk lies entirely with the user. Authorization for use is also under the condition that the instruction manual is complied with and inspection and maintenance requirements are enforced.

No change and modification to the unit can be made without the written agreement of the manufacturer. The manufacturer is not liable for damage to persons or property resulting from unauthorised modifications.

### Operators

Target groups in these instructions;

#### Operators

Operators are persons who are authorized and briefed for the use of the compressor.

#### Qualified personnel

Qualified personnel are persons who are entitled to repair, service, modify and maintain the system.



#### Warning

Only trained personnel are permitted to work on the unit!



#### Warning

Work on the electrical equipment on / with the machine / unit may only be carried out by qualified electricians.

## **SAFETY PRECAUTIONS**

---

### **Safety instructions on the unit**

Importance of notes and warning signs that are affixed to the compressor according to the application or its equipment.

**A**



**Warning**  
High voltage!



**Note**  
Ensure correct direction of rotation!



## **SAFETY PRECAUTIONS**

---

### **General Safety Precautions**

- Read the Operating Instructions of this product carefully prior to use.
- Strictly follow the instructions. The user must fully understand and strictly observe the instructions. Use the product only for the purposes specified in the intended use section of this document.
- Do not dispose the operating instructions. Ensure that they are retained and appropriately used by the product user.
- Only trained and competent personnel are permitted to use this product.
- Comply with all local and national rules and regulations associated with this product.
- Only trained and competent personnel are permitted to inspect, repair and service the product.
- Only authentic L&W parts and accessories may be used for maintenance work. Otherwise, the proper functioning of the product may be impaired.
- Do not use faulty or incomplete products. Do not modify the product.
- Inform L&W in the event of any product or component fault or failure.
- The quality of the air supply must meet EN 12021 specifications for breathing air.
- Do not use the product in areas prone to explosion or in the presence of flammable gases. The product is not designed for these applications. An explosion might be the result if certain conditions apply.

**A**



## **SAFETY PRECAUTIONS**

---

### **Unit customised safety notices**

#### **Organisational measures**

- In addition to the instruction manual, observe and comply with universally valid legal and other obligatory regulations regarding accident prevention and environment protection.
- In addition to the instruction manual, provide supplementary instructions for supervision and monitoring duties taking into consideration exceptional factors e.g. with regard to organisation of work, production, personnel employed.
- Supervise personnel's work in accordance with the instruction manual, taking into account safety and danger factors.
- Observe all safety and danger notices on the compressor and check readability and completeness.

#### **Safety instructions operation**

- Take measures to ensure that the machine is only taken into operation under safe and functional conditions. Only operate the compressor if all protective and safety equipment, e.g. detachable protective equipment, are provided and in good working order.
- Check the compressor at least once per day for obvious damage and defects. Inform the responsible department / person immediately if anything is not as it should be (including operation performance). Shut down the machine immediately if necessary and lock it.
- In case of malfunction, stop the compressor immediately and lock it. Repair malfunctions immediately.
- If there is a failure in the electric energy supply, shut the machine / unit down immediately.
- Ensure safe and environmentally friendly disposal of consumables and old parts.
- The stipulated hearing protectors must be worn.
- Soundproofing equipment on the compressor has to be activated in safety function during operation.
- When handling with fats, oils and other chemical agents, observe the note for the product-related safety.

**A**





## SAFETY PRECAUTIONS

---

### Maintenance instructions

- Hoses have to be checked by the operator (pressure and visual inspection) at reasonable intervals, even if no safety-related defects have been detected.
- Immediately repair any damage. Escaping compressed air can cause injury.
- Depressurise system and pressure lines before beginning repair work.
- Pressurised air lines must be laid and mounted by qualified personnel. Connections must not be mixed up. Fittings, length and quality of the piping must correspond to requirements.
- Adjustment, maintenance and inspection activities and keep appointments, including information on replacement parts / equipment, prescribed in the operating instructions have to be respected.
- If the machine / equipment is completely off during maintenance and repair work, it must be protected against unexpected restart. Turn off main control device and remove the key and/or display a warning sign on the main switch.
- The machine and especially the connections and fittings should be cleaned from oil, fuel and maintenance products at the beginning of the maintenance / repair. Do not use aggressive cleaning agents. Use fibre-free cleaning cloths.
- Switch off compressor and clean with a slightly damp cloth. Remove dirt from cooling pipes by using a brush.
- After cleaning, examine all pipes for leaks, loose connections, chafing and damage. Immediately eliminate any faults.
- Always retighten any screw connections loosened for maintenance or repair work.
- If it is necessary to remove safety devices for maintenance and repair work, these must be replaced and checked immediately after completion of the maintenance or repair work.
- The electrical equipment of the compressor must be regularly checked. Defects, such as loose screw connections or burnt wires, must be immediately rectified by electrically skilled personnel.
- Only personnel with particular knowledge and experience with pneumatics may carry out work on pneumatic equipment.
- Only personnel with particular knowledge and experience in gas equipment may carry out work on gas equipment.

A



## **SAFETY PRECAUTIONS**

---

### **Transportation instructions**

- Parts which need to be dismantled for transport purposes must be carefully replaced and secured before taking into operation.
- The transport may only be carried out by trained personnel.
- For transportation, only use lifting devices and equipment with sufficient lifting power.
- Do not stand or work under suspended loads.
- Also separate from minor relocation machinery / system of any external energy supply. Before recommissioning, reconnect the machine to the mains according to regulations.
- When recommissioning, proceed according to the operating instructions..

### **Safety regulations**

- Inspections according to legal and local obligatory regulations regarding accident prevention are carried out by the manufacturer or by authorised expert personnel. No guarantees whatsoever are valid for damage caused or favoured by the non-consideration of these directions for use.

**A**



A

# INSTALLATION

## INSTALLATION

---

### Installation in closed rooms



#### **Danger**

No operation in explosion-hazard areas.

The unit is not approved for operation in areas prone to explosion.

#### **For installation in closed rooms, observe the following:**

- Install the unit horizontally and level. The floor must be vibration-free and capable of taking the load of the system weight.
- The compressor room must be clean, dry, dust free and as cool as possible. Avoid direct exposure to sunlight. If possible, install unit in such a manner that the compressor fan can intake fresh air from outside. Ensure adequate ventilation and exhaust air opening.
- When locating the compressor in rooms of less than 30 m<sup>3</sup> space where natural ventilation is not ensured or other systems having high radiation are operating in the same room, measures must be taken to provide artificial ventilation.
- Intake air must be free from noxious gas e.g. smoke, solvent vapours, exhaust fumes etc.
- Observe the specified operating temperature (see "Technical Data")!

A

# INSTALLATION

## Dimensions

A

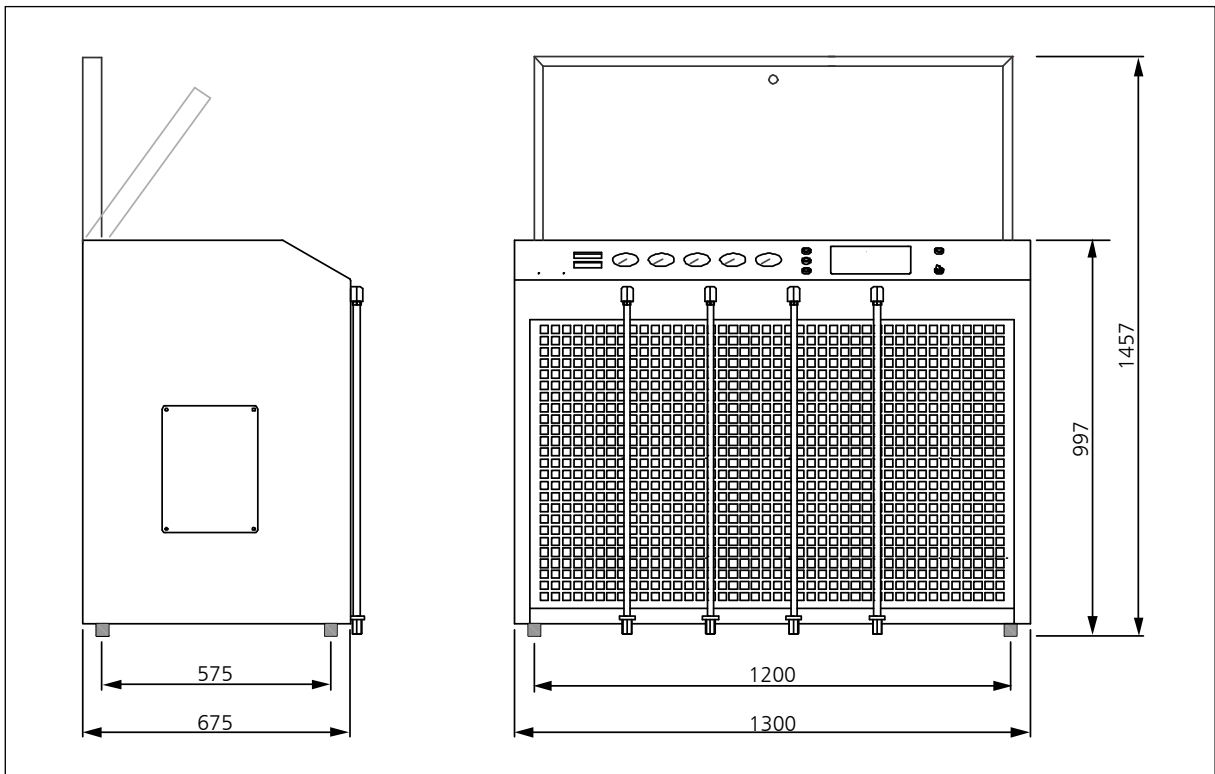

Fig. Dimensions

## INSTALLATION

### Minimum distances



#### Note

Minimum distances must be adhered!

- Make sure that the compressor always has a sufficient amount of fresh air available.
- To prevent serious damage, ensure that the cooling air flow can flow freely.
- The following minimum distances must be adhered:  
Front side min. 1500 mm, sides min. 500 mm, rear side min. 500 mm.  
Avoid anything in this area which can restrict the cooling air flow.

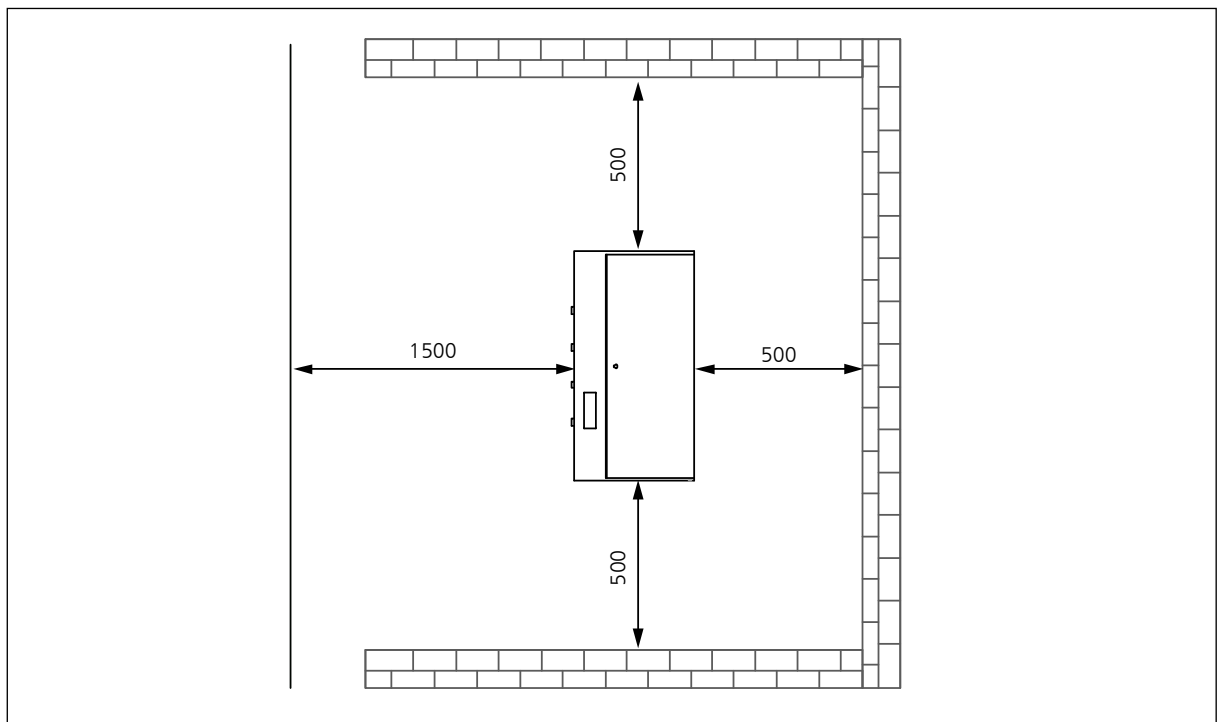

Fig. Minimum distances

## INSTALLATION

### Ventilation

- Make sure that the compressor always has a sufficient amount of fresh air available for cooling.
- To prevent serious damage, ensure that the cooling air flow can flow freely.
- The necessary cooling air flow can be calculated by using the following formula:  
 $300 \times \text{drive power [kW]} = \text{required cooling air flow [m}^3/\text{h]}$   
 Example 11kW motor:  $300 \times 11\text{kW} = 3300 \text{ m}^3/\text{h} = \text{required cooling air flow.}$
- The fan capacity for fresh air and warm air must meet at least the required cooling air flow.  
 The fans must have the same capacity.

A

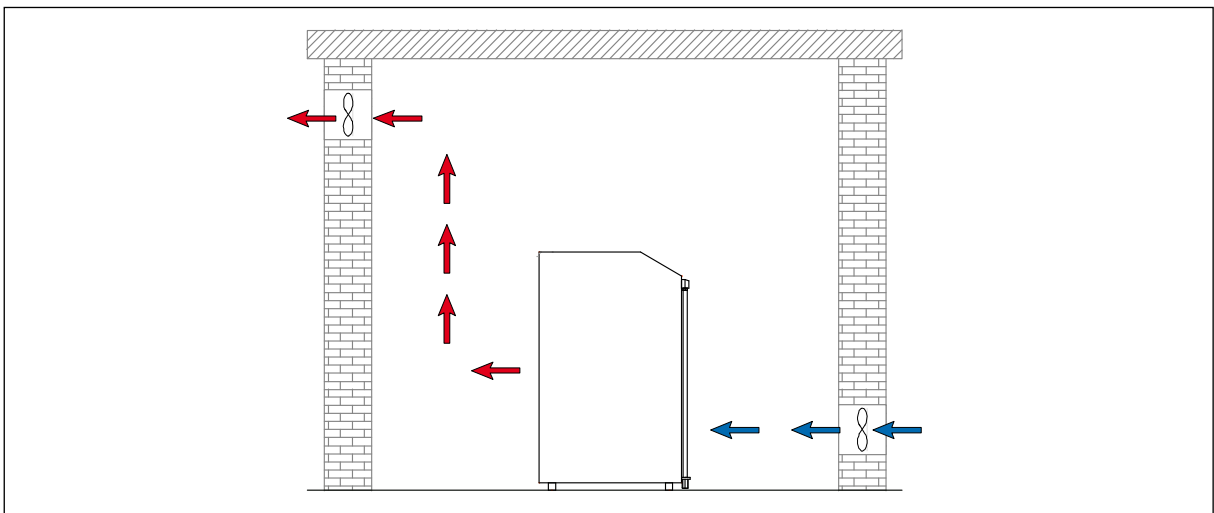

Fig. Ventilation through facade

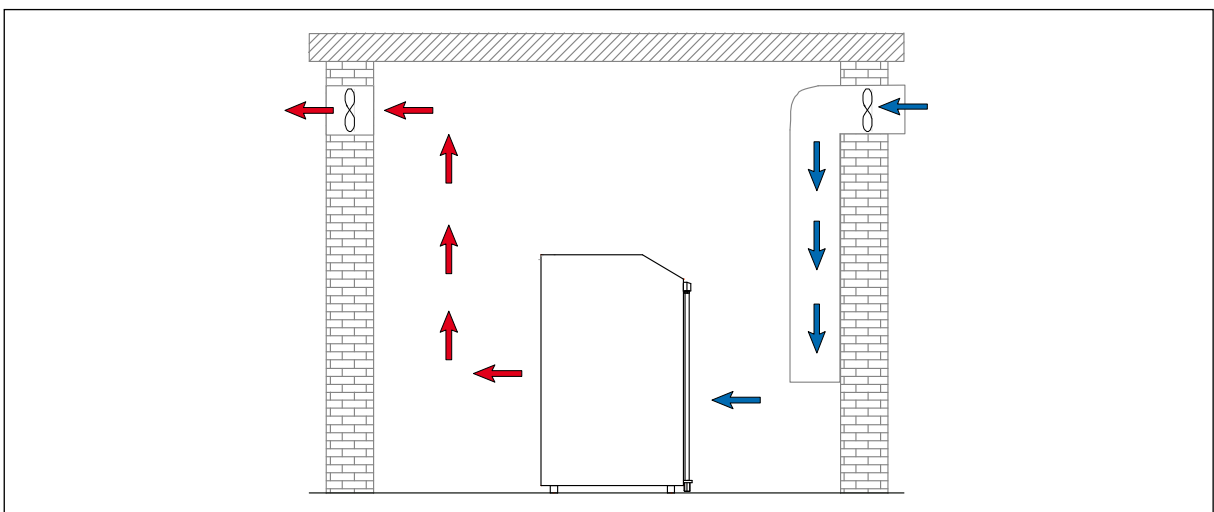

Fig. Ventilation via ventilation stack

## INSTALLATION

### Electrical Installation



#### Warning

Work on the electrical equipment on / with the machine / unit may only be carried out by qualified electricians.

For installation of electrical equipment, observe the following:

- If control devices are delivered by the factory, refer to the appropriate wiring diagram.
- Ensure correct installation of protective conductors.
- Check conformity of motor and control device tension and frequency with those of the electric network (see name plate on the compressor).
- The fusing should be done in accordance with the valid regulations of the responsible electricity supply company.
- When connecting the unit to the electrical supply, check the compressor direction of rotation (see chapter "Maintenance" -> Check turning direction).
- Fuse the motor correctly (see table; use slow-blow fuses).

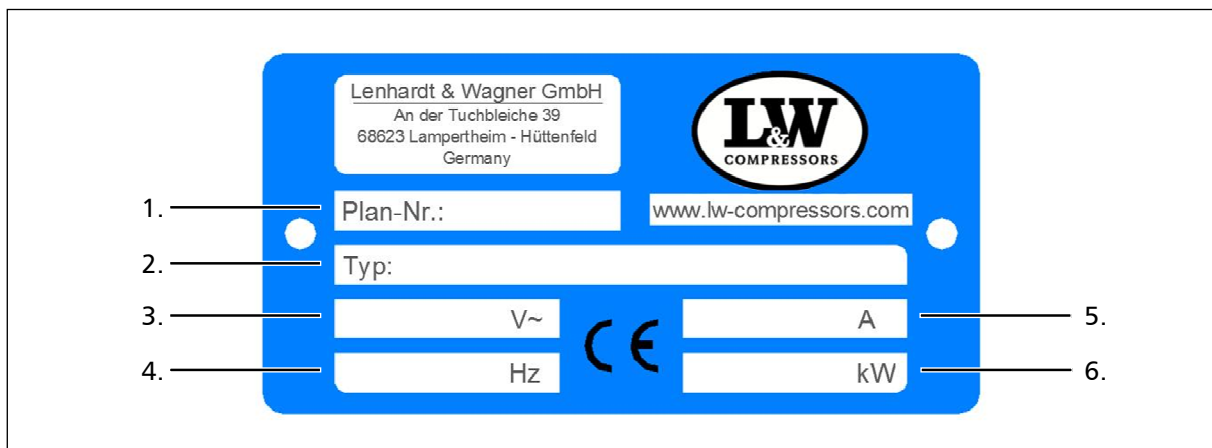

Fig. Compressor name plate

No.	Designation
1.	Circuit diagram number
2.	Compressor type
3.	Power supply
4.	Frequency
5.	Motor current consumption
6.	Nominal motor power



## INSTALLATION

### Electrical Installation

The standard compressor version is prepared for the connection to three phases (brown, black, grey), neutral conductor (blue) and protective earth conductor (green/yellow).

Fig. - Connection to the switch box

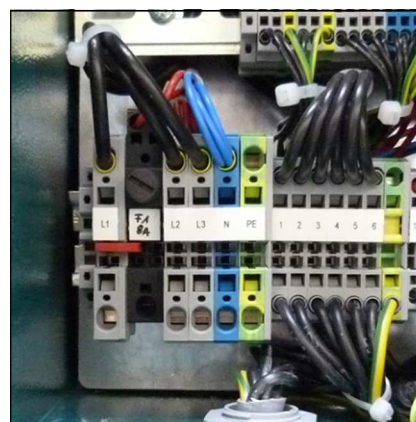

A

### Recommended fuses for 360 - 500 V operating voltage

Nominal motor power		Fusing start A		Connection in mm <sup>2</sup>	
[kw]	[A]	Direct	Star/Delta	Contactor supply	Motor S/D
2.2	5	10	-	1.5	1.5
4	8.5	20	-	2.5	1.5
5.5	11.3	25	20	2.5	1.5
7.5	15.2	30	25	2.5	1.5
11	21.7	-	35	4	2.5
15	29.9	-	35	6	4
18.5	36	-	50	6	4
22	41	-	50	10	4
30	55	-	63	10	6

### Recommended fuses for 220 - 240 V operating voltage

Nominal motor power		Fusing start A		Connection in mm <sup>2</sup>	
[kw]	[A]	Direct	Star/Delta	Contactor supply	Motor S/D
2.2	8.7	20	-	1.5	1.5
4	14.8	25	-	2.5	1.5
5.5	19.6	35	25	4	2.5
7.5	26.4	50	35	6	4
11	38	-	50	6	4
15	51	-	63	10	4
18.5	63	-	80	16	6
22	71	-	80	16	6
30	96	-	125	25	10



A

# OPERATION



## OPERATION

---

### Important operation instructions



#### Note

Ensure that all persons handling the compressor are familiar with function and operation of the unit.



#### Wear hearing protection

When working on a running machine, always wear hearing protection.

A

## FIRST COMMISSIONING

---

### Prior to first commissioning, observe the following:

Necessary steps are described on the next page.

- Ensure that cooling air can flow freely.
- Check compressor oil level by the oil sight glass (see next page).
- Check all connections and retighten if necessary.
- Check if the filter cartridge is in place (see "Service and Maintenance").
- Check the V-belt tension (see next page).
- Check if all filling valves are closed. Open one filling valve and hold tight manually!

### Start the compressor

1. Start the compressor by pushing the ON button.
2. Check turning direction - see the rotary direction arrow on the housing of the electric motor (see next pages). If the turning direction is wrong, immediately stop the compressor by pushing the OFF button and contact an authorised electrician.



#### Warning

Wrong impeller rotation direction!

Immediately after switching the compressor on, check the rotation direction. Depending on the place of installation, the phase sequence can influence the rotation direction.

3. Check oil pressure (if oil pressure gauge is installed).
4. Run the compressor for about 2 minutes.
5. Close the open filling valve carefully.
6. Run the compressor up to maximum pressure and check if the final pressure switch shuts off the compressor. If the final pressure switch does not shut off, switch off the compressor with the OFF button (see chapter "REMEDYING FAULTS").
7. Check the compressor unit for leaks (see "SERVICE AND MAINTENANCE")
8. Now check the condensate drain valves:
  - Fix the black condensate hoses
  - Drain test - press the test button
  - If correct, air escapes
9. Stop the compressor by pushing the OFF button.
10. Open all filling valves carefully to vent.

## FIRST COMMISSIONING

### Check oil level



#### Warning

Check oil level daily. Never start the compressor with a too low oil level. Risk of accidental loss, destruction or deterioration.

Check oil before each operation of the system!

The oil level should be between the middle and upper end of the oil sight glass. Never start the compressor with a too low oil level.

Refill new compressor oil at least when the oil level reached the middle of the indicated area.

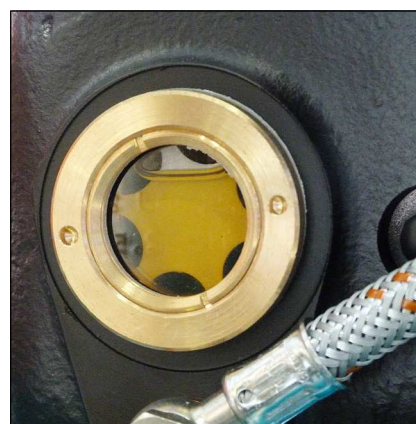

Oil sight glass

### Check V-belt tension

The V-belts could lose tension during transportation. Please check the V-belt tension before starting the compressor.

#### Tension V-belts

To tighten V-belt tension, loosen 4 mounting nuts of the drive motor. Use the tensioning screw to move the electric motor until the V-belt tension is sufficient. Then, tighten mounting nuts and check V-belt tension.

We recommend using a V-belt tension gauge.

#### Correct V-belt tension

Do not tension V-belts too tight. This damages bearings of compressor and motor. The V-belts should only be tensioned until there is no noise caused by slipping during start.

### Settings

Motor Type	Initial Installation	Operation after running in
Electric motors 50Hz	500 N	400 N
Electric motors 60Hz	400 N	300 N

## FIRST COMMISSIONING

---

### Check turning direction



#### Warning

Wrong impeller rotation direction!

Immediately after switching the compressor on, check rotation direction. Depending on the place of installation, the phase sequence can influence the rotation direction.

Before starting the compressor for the first time, check rotation direction (see the rotary direction arrow on the housing of the electric motor).

If the direction of rotation is wrong, the guide pistons can not be sufficiently lubricated, with the consequence that the pistons will be damaged. Furthermore, cooling air flow will not be sufficient.

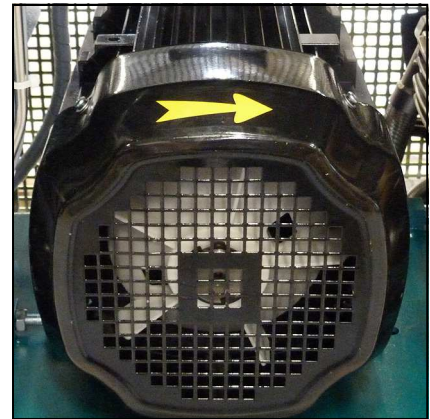

Rotation direction arrow

A



## DAILY COMMISSIONING

---

### **Prior to daily operation observe the following:**

- Ensure cooling air can flow freely.
- Check compressor oil level by the oil sight glass.
- Check if filter cartridge is in place / observe filter cartridge life!
- Ensure toxic-free, pure intake air.

A

## OPERATION

---

### Filling procedure



**Caution! Fill only cylinders which:**

- are marked with the test mark and the test stamp of the expert.
- have been hydrostatic tested (check last test date).
- are rated for the final pressure.
- are free from humidity.



**Note**

The unit shuts down when final pressure is reached. Thus, the unit always has to be restarted manually.

1. Close all filling valves.
2. Connect the closed compressed air cylinders.
3. Open cylinder valves.
4. Start compressor by pushing the ON button.
5. When the filling pressure gauge increases, open the filling valves slowly.
6. Fill compressed air cylinders to the desired pressure, subsequently close the filling valves slowly.
7. Close and vent all filling valves.
8. Disconnect all compressed air cylinders from filling valves.

A





## OPERATION

---

### Switch off the compressor

The compressor unit is equipped as standard with a pressure switch which automatically shuts down the system when the corresponding final pressure is reached.

During filling process, you can shut down the system at any time by pushing the red button (OFF) or the emergency stop (only in case of emergency!).



#### Note

After automatic or manual switching off, all pressure vessels and filter housings of the compressor will be automatically vented.

A



A

# REMEDYING FAULTS

## REMEDYING FAULTS

A

### Final pressure can not be reached

Cause of fault	Remedy
Connections leaky	Retighten or clean/replace if necessary
Final pressure safety valve leaky	Replace
Pipes / heat exchanger broken	Replace
Condensate drain valves leaky	Unscrew valves, check sealing surfaces, clean, replace if necessary
Final pressure switch stop unit	Verify settings, replace if necessary
Piston of pneumatic condensate valve sticks	Clean pneumatic condensate valve and restore function, check/replace o-rings, replace valve completely if necessary

### Strong compressor vibration

Cause of fault	Remedy
V-belt tension too loose	Tension V-belt
Drive motor / Compressor unit loosely	Retighten mounting screws
Anti vibration mounts used up	Replace
Ground not levelled	Ensure a solid and level ground

### Air supply too low

Cause of fault	Remedy
Inlet and outlet valves contaminated / defective	Clean, replace if necessary
Cylinder(s), piston(s) or piston ring(s) used up	Replace
V-belt slips	Tension V-belt
See chapter "Final pressure can not be reached"	See chapter "Final pressure can not be reached"

## REMEDYING FAULTS

### Compressor overheated

Cause of fault	Remedy
Inlet filter cartridge contaminated	Replace
Ambient temperature too high	Improve room ventilation / Reduce operation times
Cooling air inlet and outlet insufficient	Observe minimum distances (see Installation Instructions)
Air intake hose too long	Reduce length of the air intake hose
Air intake hose diameter too small	Use a larger diameter
Wrong compressor rotation direction	Ensure correct phase rotation, observe rotation direction arrow!
Inlet and outlet valves contaminated / defective	Clean, replace if necessary

### Safety valve leaks

Cause of fault	Remedy
Inlet and outlet valves of the following pressure stage defective	Clean, replace if necessary
Sinter filter of the following water separator blocked	Replace
Safety valve leaky	Replace

### Oil taste in the air

Cause of fault	Remedy
Mole carbon filter cartridge saturated	Replace
Compressor oil unsuitable	Use prescribed oil quality
Filter cartridge unsuitable	Use prescribed filter type
Cylinder(s), piston(s) or piston ring(s) defective	Replace

## REMEDYING FAULTS

### Automatic condensate drain defective

Cause of fault	Remedy
Solenoid coils defective	Replace
Cable / supply cable defective	Repair, replace if necessary
Timer / relais defective	Replace
Sinter filter of pneumatic condensate valve blocked	Replace
Piston of pneumatic condensate valve sticks	Clean pneumatic condensate valve and restore function, check/replace o-rings, replace valve complete if necessary

### Condensate drain starts before reaching final pressure

Cause of fault	Remedy
Pressure stages are not as prescribed, control pressure of pneumatic condensate valve too low	Check corresponding inlet and outlet valve, replace if necessary.
Piston sealing of pneumatic condensate valve contaminated / used up	Clean, replace if necessary
Timer / relais settings not correct	Adjust as prescribed
Timer / relais defective	Replace

### Compressor stops before final pressure

Cause of fault	Remedy
Final pressure switch settings not correct	Correct settings
Opening pressure of the pressure maintaining valve too high	Correct settings
Fuse / circuit breaker has tripped Valid only for E models	Check fusing of the power supply / observe regulations
Emergency stop switch has tripped	Unlock emergency stop switch, close compressor housing door correctly

## REMEDYING FAULTS

### Filter life not sufficient

Cause of fault	Remedy
Pressure maintaining valve settings not correct	Adjust as prescribed
Filter cartridge unsuitable	Replace by a prescribed filter cartridge type
Filter cartridge too old	Observe expiration date
Filter cartridge packaging incorrect / damaged / already opened. Filter cartridge already partly saturated before change	Store filter cartridges properly, dispose defective cartridges
Operating temperature too high	Ensure sufficient ventilation
Cylinder(s), piston(s) or piston ring(s) defective	Replace

### Oil consumption too high

Cause of fault	Remedy
Cylinder(s), piston(s) or piston ring(s) defective	Replace
Compressor oil unsuitable	Use prescribed oil quality
Operating temperature too high	Observe prescribed operating temperatures
Oil leak at the compressor block	Tighten corresponding mounting screws, if necessary replace corresponding paper sealing / o-ring / shaft seal



A

# MAINTENANCE AND SERVICE

## MAINTENANCE AND SERVICE

---

### Service, Repair and Maintenance

Carry out service and maintenance work exclusively when the compressor is stopped and depressurised. The unit should be leak-checked regularly. Leaks can be preferably localised by using a leak detector spray (if necessary, brush pipes with soapy water).

We recommend that only authorised L&W service technicians carry out service work on the bearing of the compressor (crankshaft and connecting rods).

We urgently recommend that all maintenance, repair and installation work must only be carried out by trained personnel. This is necessary because all maintenance work can not be explained exactly and detailed in this manual.

Only use authentic spare parts for service work.



#### **Danger**

Components under pressure, such as hose ends, can quickly come loose when manipulated and can cause potentially fatal injuries due to the pressure surge. Any work on system parts may only be performed in a pressure-compensated state.



#### **Warning**

The use of accessories that have not been tested can lead to death or serious injury or damage to the unit. Only use authentic spare parts for service work.



#### **Warning**

Carry out maintenance or service work when the unit is switched off and protected against unexpected restart.



#### **Warning**

The maintenance cover must be opened completely for service or repair work otherwise there is a risk of injury when the cover falls down.



#### **Warning**

Risk of burns!

Carry out maintenance or service work when the unit has cooled down.





## MAINTENANCE AND SERVICE

---

### Daily before taking unit into operation

Maintenance work	Type	Quantity	Order No.
Check oil level	-	-	000001
Check condition of all filling hoses	-	-	-
Check filter cartridge lifetime	-	-	-
Operate unit to final pressure and check function of final pressure switch	-	-	-

### At 25 operation hours

Maintenance work	Type	Quantity	Order No.
Oil change	-	2,5	000001

### Every 3 months or as required

Maintenance work	Type	Quantity	Order No.
Check automatic condensate drain, open manual condensate taps	-	-	-
Check/Retorque all connections and bolts	-	-	-

A



## MAINTENANCE AND SERVICE

### Annually

Maintenance work	Type	Quantity	Order No.
Oil change, if less than 1000 operating hours	-	2.5	000001
Check opening pressure of final safety valve	-	-	-
Clean coolers	-	-	-
Clean all oil/water separators, if less than 500 operating hours	-	-	-
Service intake filter (depends on condition - if less than 500 operating hours)	-	-	-
Check all connections for leakage	-	-	-

### Every 500 operating hours

Maintenance work	Type	Quantity	Order No.
Change intake filter	-	1	000170
Check pressure maintaining/non-return valve	-	-	-
Check V-belt tension and condition	-	-	-



## MAINTENANCE AND SERVICE

### Every 1000 operating hours

Maintenance work	Type	Quantity	Order No.
Replace sintered metal filter element of water	1 / 2 / 3 stage	3	000173
Replace o-rings of water separators	1 / 2 / 3 stage	9	001272
Replace o-ring of oil separator	-	1	001294
Replace silencer	-	1	000178
Replace sintered metal filter of oil separators	-	1	000184
Replace sintered metal filter of pneumatic condensate valve	-	1	000188
Replace oil sieve / oil pump cover gasket	-	1	002569
Oil change	-	2.5	000001
Replace o-rings of the final filter housing	-	2	001287
Replace back-up rings of the final filter housing	-	2	001285

A



## MAINTENANCE AND SERVICE

### Every 2000 operating hours

Maintenance work	Type	Quantity	Order No.
Replace all inlet and outlet valves incl. gaskets	1st stage	1	000369
	2nd stage	1	000256
	3rd stage	1	010346
	4th stage	1	010347
	Upper gasket 1st	1	000349
	Upper gasket 2nd	1	000254
	Lower gasket 1st	1	000350
	Lower gasket 2nd	1	003492

### Every 4000 operating hours (Latest in 10 years)

Maintenance work	Type	Quantity	Order No.
Replace all o-rings and gaskets of 1st, 2nd, 3rd and 4th stage	O-ring	1	000409
	gasket	3	000240
	o-ring	2	001274
Replace shaft seal	-	1	000244
Replace needle bearings for conrod 2nd, 3rd and 4th stage	-	3	003281
CU-Ring (Ø10 x 16 x 2mm)	-	16	001323

A



## MAINTENANCE AND SERVICE

---

### Check V-belt tension

The V-belts could lose tension during transportation. Please check the V-belt tension before starting the compressor.

A

### Tension V-belts

To tighten V-belt tension, loosen 4 mounting nuts of the drive motor. Use the tensioning screw to move the electric motor until the V-belt tension is sufficient. Then, tighten mounting nuts and check V-belt tension.

We recommend using a V-belt tension gauge.

### Correct V-belt tension

Do not tension V-belts too tight. This damages bearings of compressor and motor. The V-belts should only be tensioned until there is no noise caused by slipping during start.

### Settings

Motor Type	Initial Installation	Operation after running in
Electric motors 50Hz	500 N	400 N
Electric motors 60Hz	400 N	300 N

## MAINTENANCE AND SERVICE

### Compressor lubrication

Crankshaft bearings of the 1st and 2nd stage get lubrication by an oil slinger. In addition, 1st and 2nd stage are lubricated by spray oil. The guide cylinder of the 3rd stage is lubricated by a mechanical oil pump.

A

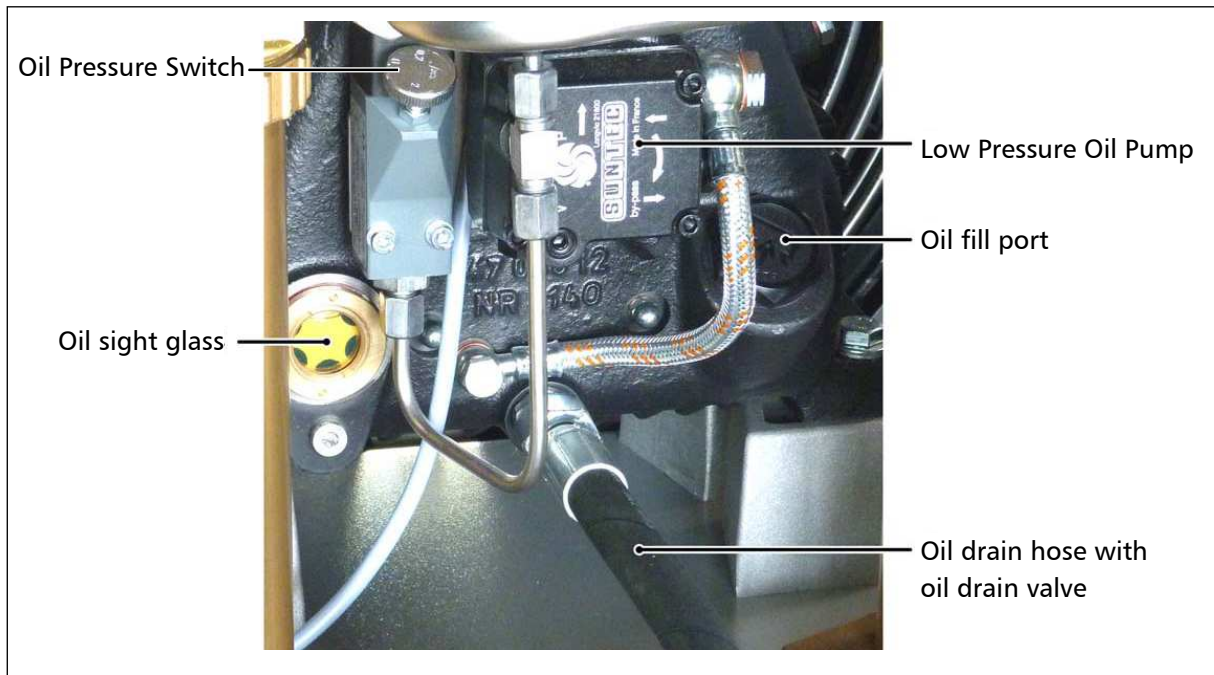

Lubricating System

### Check oil level



#### Warning

Check oil level daily. Never start the compressor with a too low oil level. Risk of accidental loss, destruction or deterioration.

Check oil before each operation of the system!

The oil level should be between the middle and upper end of the oil sight glass. Never start the compressor with a too low oil level.

Refill new compressor oil at least when the oil level reached the middle of the indicated area.

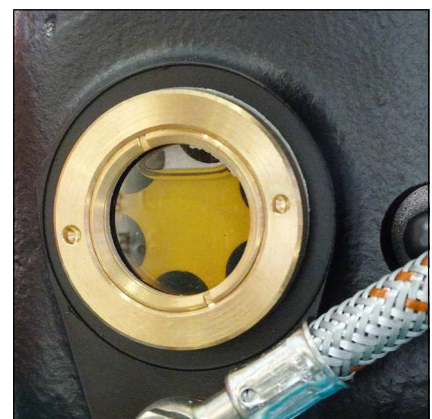

Oil sight glass

### Oil change



#### Note

We recommend oil change at least once a year - depending on total operating hours.

A

#### Oil change as follows:

- Run compressor warm for approx. 2 min.
- Switch off and vent compressor.
- Place a suitable oil drain tray under the drain hose.
- Open carefully oil drain valve and drain oil completely.
- Close oil drain valve.
- Loosen oil fill port with an appropriate adjustable wrench (AF 0-40 mm) and unscrew manually.
- Fill oil by using a funnel.
- Check oil level. The oil level should be between the middle and upper end of the oil sight glass.
- Screw oil fill port manually in and tighten with the adjustable wrench.

The oil change is now completed.

#### Maintenance intervals

- First oil change after 25 operating hours (total hours).
- All further changes after each 1,000 operating hours.

#### Oil and oil capacity

Approx. 2,500 ml synthetic compressor oil is necessary for one oil change. Only use synthetic compressor oil which is recommended as suitable from L&W.

## MAINTENANCE AND SERVICE

### Oil sieve change

Oil sieve change as follows:

- Loosen cover screws (4 pcs).
- Remove the cover, the cover gasket and the oil sieve.
- Clean the oil sieve with petroleum-ether or replace the defective oil sieve.
- Replace the gaskets.
- Soak the gaskets with oil before placing (respect mounting direction).
- Be sure to position the arrow (see Fig., Pos. 1) from the new oil sieve opposite to inlet and return ports of the pump (see Fig., Pos. 2).
- Remount the cover with the 4 cover screws. Tightening torque: 4.5 - 8 N.

The oil sieve change is now completed.

### Maintenance intervals

- We recommend cleaning or replacing the oil sieve every 1,000 working hours.
- Service Kit oil pump (002569). Consists of: 000798—Oil sieve + 000672—oil pump cover gasket

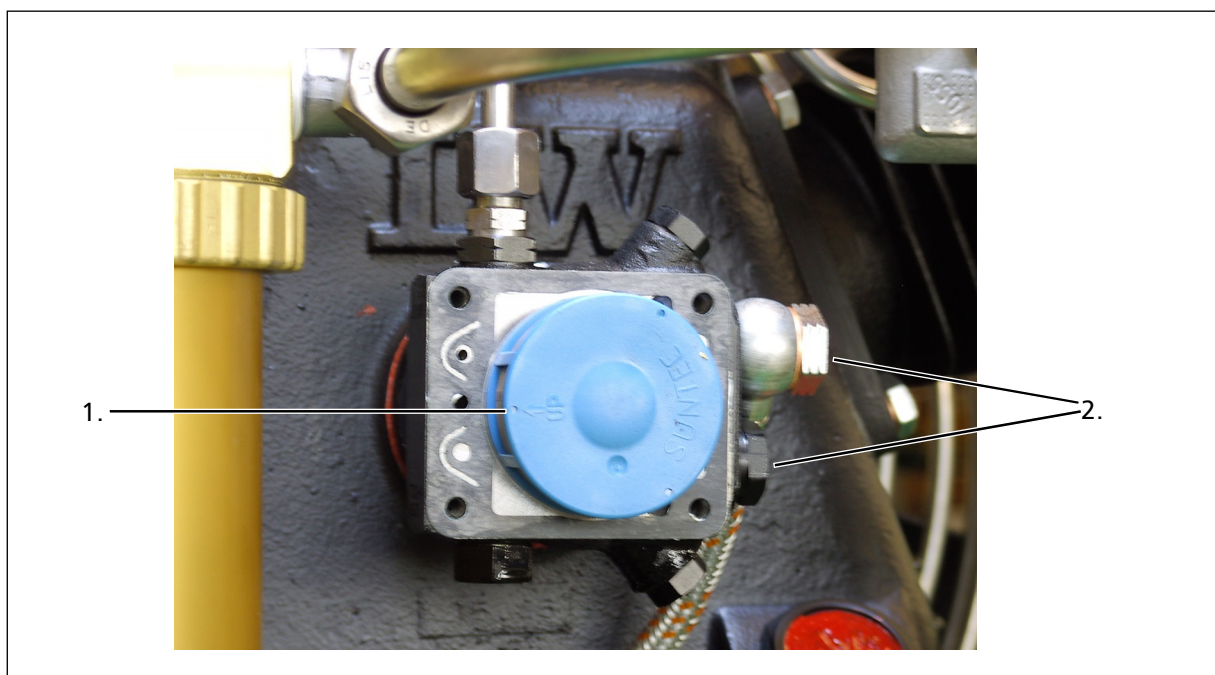

Correct oil sieve mounting direction



### Final pressure switch



**Note**

Do not adjust the final pressure switch to the safety valve pressure. The final pressure switch has to be adjusted to min. 10 bar below the safety valve pressure. Otherwise, the safety valve can open during operation. This considerably reduces the life of the safety valve.

The pressure switch shuts off the compressor automatically when the selected final pressure is reached. The final pressure switch is already adjusted to the corresponding cut-out pressure.

The pressure can be adjusted with the upper adjusting screw as follows:

**Increasing cut-out pressure:**

Turn the adjusting screw clockwise

**Reducing cut-out pressure:**

Turn the adjusting screw anti-clockwise

Adjust the pressure switch in steps of a quarter turn. Restart the compressor after every adjustment step to verify the actual cut-out pressure.

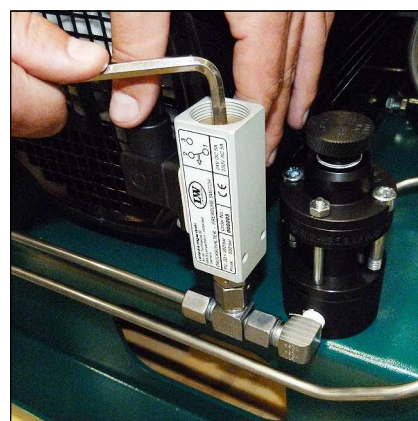

Final pressure switch

**Example settings:**

Safety valve	Max. Operating Pressure
225 bar	215 bar
250 bar	240 bar
330 bar	320 bar

## MAINTENANCE AND SERVICE

### Automatic condensation dump system



#### Note

The collected condensate can contain oil and has to be disposed according to regulations.

The LW 570 E comes as standard with an automatic condensation dump system. Solenoids drain all condensate separators every 15 minutes.

To test the system, press the blue condensate test drain button on the operating panel.

### Oil / water separators

Condensate is separated after every stage of compression. All four oil / water separators are equipped with electronic timer controlled solenoids. The timer is located in the switch box and activates the dump valves about every 15 minutes.

To release the complete condensate through the black plastic hoses, we recommend using an 20 l container at least.

The drain noise can be kept to a minimum by using a silencer.

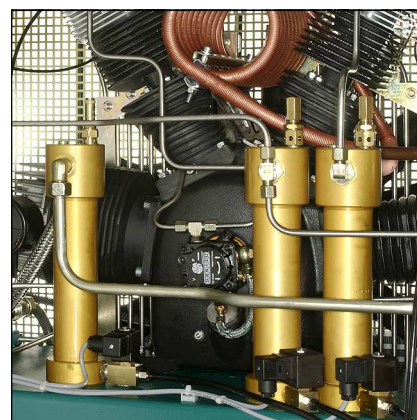

Oil / water separators 1st, 2nd and 3rd stage

### Maintenance intervals

We recommend to clean oil and water separators every 500 operating hours or at least once a year, to check for corrosion damage and to replace o-rings if necessary.

All oil / water separators have an integrated sinter filter which has to be replaced every 1,000 operating hours.

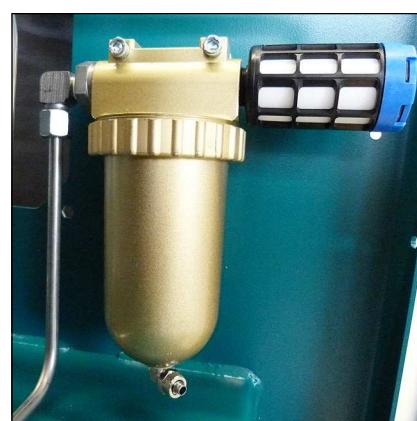

Oil / water separators final stage

## MAINTENANCE AND SERVICE

### Oil / water separators 1st, 2nd and 3rd stage - maintenance



#### Note

Clean all parts thoroughly before assembly.

#### Maintenance / cleaning of oil / water separators as follows:

- Loosen pipe connections and mounting screws.
- Remove oil / water separators.
- Unscrew and remove filter top (Fig. 1).
- Open nut and remove separator top (Fig. 2).
- Change sinter filter (Fig. 3).
- Reassemble all parts and tighten nut.
- Change o-ring, previously grease new o-ring (Fig. 4).
- Place separator top and tighten manually.
- Remove bottom part (Fig. 5)
- Change o-ring, previously grease new o-ring
- Press in bottom part
- Mount oil / water separators.
- Tighten pipe connections and mounting screws.

The oil / water separator maintenance is now completed.



Fig. 1 - Unscrew and remove filter top

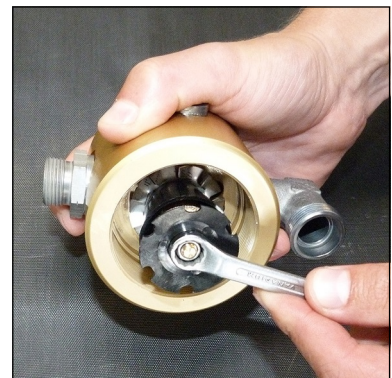

Fig. 2 - Loosen nut at the separator top

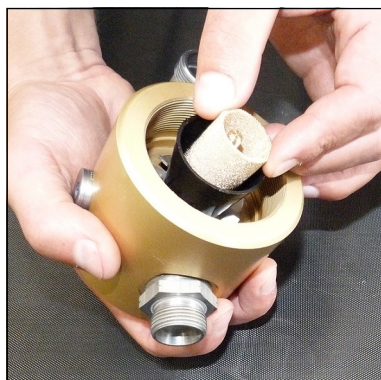

Fig. 3 - Change sinter filter

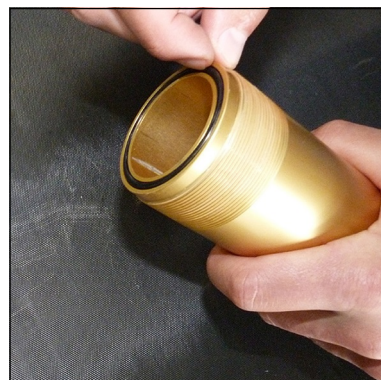

Fig. 4 - Change o-ring



Fig. 5 - Bottom part

## MAINTENANCE AND SERVICE

### Oil / water separators final stage - maintenance



#### Note

Clean all parts thoroughly before assembly.

#### Change/clean oil / water separators final stage as follows:

- Loosen pipe connections and mounting screws.
- Remove oil / water separators.
- Open ring nut and remove separator top (Fig. 1).
- Loosen nut at the separator top.
- Change sinter filter (Fig. 2).
- Reassemble all parts and tighten nut.
- Change o-ring, previously grease new o-ring (Fig. 3).
- Place separator top and tighten ring nut manually.
- Replace silencer.
- Mount oil / water separators.
- Tighten pipe connections and mounting screws.

The oil / water separator maintenance is now completed.



Oil / water separators final stage



Fig. 1 - Loosen ring nut

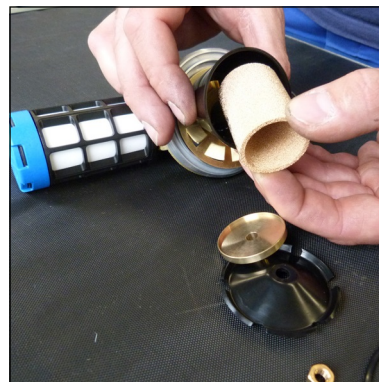

Fig. 2 - Change sinter filter



Fig. 3 - Change o-ring

### Pneumatic condensate valve - maintenance



#### Note

Clean all parts thoroughly before assembly.

#### Pneumatic condensate valve change as follows:

- Loosen pipe connections and mounting screws.
- Remove pneumatic condensate valve.
- Loosen connection (Fig. 2).
- Change sinter filter (Fig. 3).
- Tighten horizontal screw.
- Mount pneumatic condensate valve.
- Tighten pipe connections and mounting screws.

**Pneumatic condensate valve maintenance is now completed.**

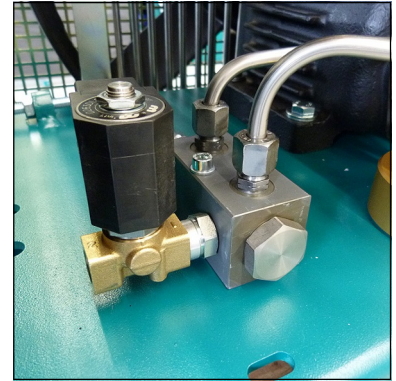

Pneumatic Condensate Valve

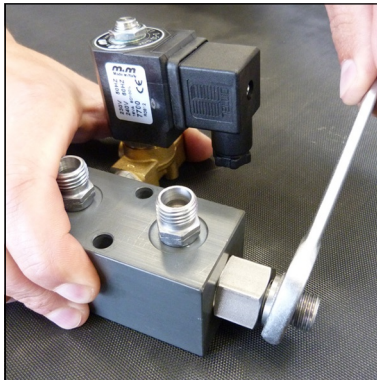

Fig. 2 - Loosen connection

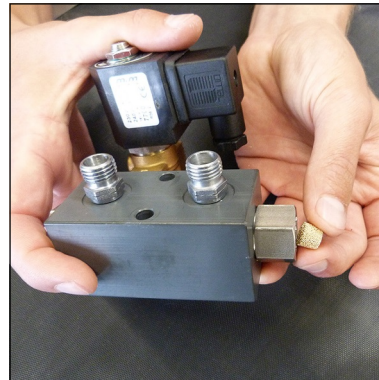

Fig. 3 - Change sinter filter

## MAINTENANCE AND SERVICE

### Filter housing

The mole carbon filter housing is installed on the right hand side of the compressor housing.

Inside the filter housing a jet blows air on to the housing wall. Condensation water and oil are led by centrifugal force to the bottom of the housing. Air flows through the mole carbon filter cartridge, which purifies the air from residual moisture and odours.



Filter housing

### Filter cartridge

The high-pressure compressor is equipped with an integrated breathing air purification system. Air is compressed up to 330 bar, dried and odour- and tasteless purified. Oil residues are bounded. The breathing air filter cartridge consists of a molecular sieve and activated-carbon filter.

Cartridge capacity: approx. 1.7 l (LW SC-600 E)

Cartridge capacity: approx. 2.3 l (LW SC-680 E + LW SC-750 E)

All breathing air filter cartridges are factory vacuum sealed.

We recommend unpacking the filter cartridges just before installation. Filter cartridges which are exposed too long could be saturated with moisture and become unusable.

### Maintenance intervals

Filter cartridges should be changed at the following intervals, at +20°C or more often, depending on humidity and ambient temperature:

- 35 hours

## MAINTENANCE AND SERVICE

### Filter cartridge change

Filter cartridge change as follows:

- Run the compressor up to a pressure of 100 bar.
- Stop compressor.
- Open filling valve.
- Unscrew filter housing cover by using the special filter tool (Fig. 1).
- Place the T-piece end of the filter tool in the recess of the filter cartridge (Fig. 2).
- Unscrew the filter cartridge anti-clockwise and pull the cartridge out of the housing (Fig. 3).
- Open the packing of the new filter cartridge and place it with the filter tool in the filter housing.
- Screw the new filter cartridge hand tight in by using the filter tool.
- Screw the cover of the filter housing first manually in.
- After it has been completely screwed in, turn cover anticlockwise for 90°. This avoids tightening of the cover due to vibration..

The filter cartridge change is now completed.



#### Note

Ensure that the old filter cartridge is disposed correctly at an approved waste point.



Fig. 1 - Unscrew the filter housing cover.



Fig. 2 - Place the T-piece end of the filter key in the top of the filter cartridge.



Fig. 3 - Pull the cartridge out of the housing.

A

### Filter housing - maintenance



#### Note

Clean all parts thoroughly before assembly.

#### Filter housing maintenance as follows:

- Open Filter Cover (Fig. 1).
- Change o-ring and back-up ring, previously grease both (Fig. 2).
- Grease filter cover thread and close.

#### Dismount filter housing

- Loosen pipe connections and nuts (Fig. 3).
- Remove filter housing.
- Dismount filter housing base.
- Change o-ring and back-up ring, previously grease both (Fig. 4).
- Screw filter base tight in.

#### Mount filter housing

- Connect pipe connections and tighten.
- Adjust holding clamp and tighten nuts.

The filter housing maintenance is now completed.

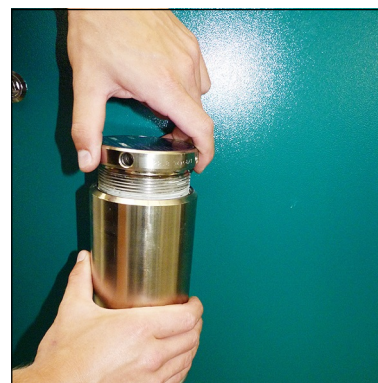

Fig. 1 - Open Filter cover

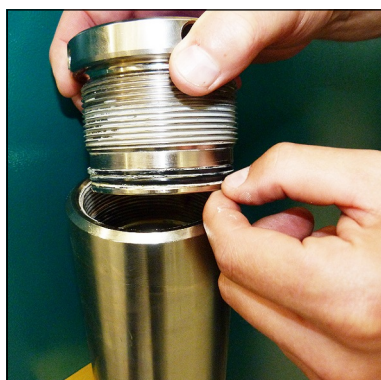

Fig. 2 - Change o-ring and back-up rings

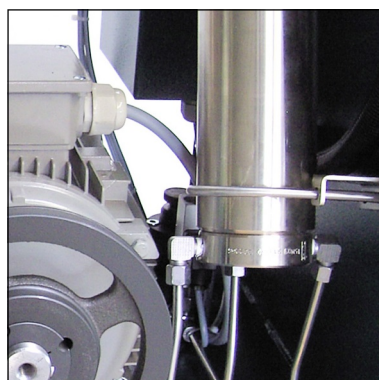

Fig. 3 - Loosen pipe connections and nuts



Fig. 4 - Change o-ring and back-up rings



### Inlet Filters



#### Note

Dirty filters make intaking air difficult and reduce delivery capacity. Risk of compressor overheating.

A micro filter cartridge is used as an air inlet filter. Check air inlet filter regularly or replace if necessary. Defective air inlet filters should be immediately replaced.

### Maintenance Intervals

We recommend that the filter cartridge should be replaced every 1,000 working hours (depending on pollution grade).

### Inlet Filter Cartridge Change

Inlet filter cartridge change as follows:

- Loose nut (Fig.1)
- Remove cover and replace filter cartridge by a new one (Fig.2)
- Assemble intake filter
- Tighten nut

The inlet filter cartridge change is now completed.

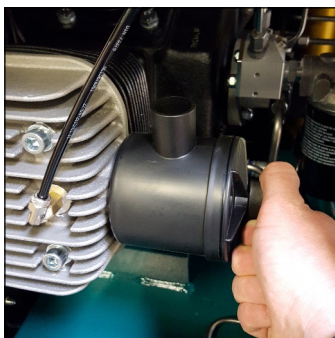

(Fig.1) Loose nut

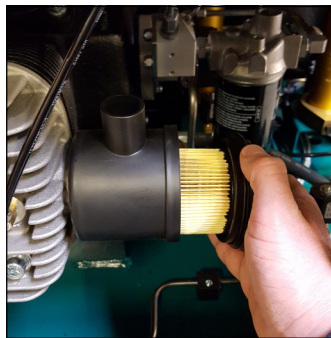

(Fig.2) Remove cover and replace filter cartridge

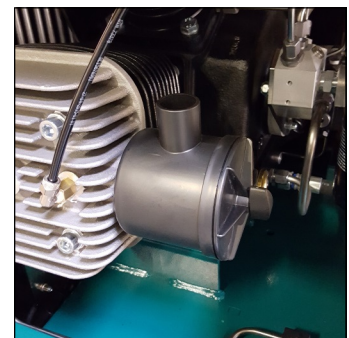

(Fig.3) Mount the intake filter

## MAINTENANCE AND SERVICE

---

### Cylinder heads and valves

Inlet and outlet valves of the specific compressor stages are located between valve head and cylinder. Outlet valves open while piston downstroke, inlet valves open while upstroke or compression stroke.

Valves are subject to normal wear and tear and have to be replaced at certain intervals (depending on specific operating conditions). Dismount valve heads to change valves. The three valves are combined inlet and outlet valves. The first and second stage valves are plate valves. The third stage contains a spring operated piston which acts inside a bronze cylinder.

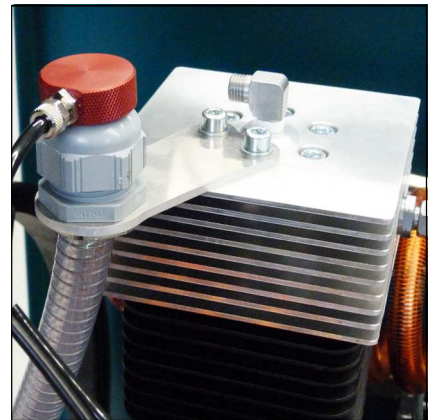

Valve head 3rd stage

### Maintenance intervals

All valves should be replaced after 2,000 working hours due to normal wear and tear. To replace valves the cylinder heads have to be removed. There are no special tools required to replace these valves.

### Available special tools

Special tools are not necessary for dismounting inlet and outlet valves but make work easier.

Order number: 006847



Special tool

## MAINTENANCE AND SERVICE

### Replace inlet and outlet valves 1st and 2nd stage



#### Note

The figures of the parts can differ due to the different stages.

Change inlet and outlet valves 1st and 2nd stage as follows:

#### Remove Inlet / Outlet Valve

- Loosen pipe connections
- Loosen valve head screws (Fig. 1)
- Remove valve head
- Pull out inlet and outlet valve (Fig. 2). CAUTION: Observe that the lower copper valve ring is also pulled out. (It can still stick inside the cylinder)
- Check valve head if defective

Install Inlet / Outlet Valve - see following page

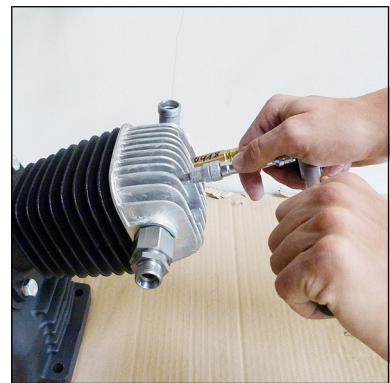

Fig. 1 - Loosen valve head screws



Fig. 2 - Pull out inlet and outlet valve

### Replace inlet and outlet valves 1st and 2nd stage - continued from previous page

A



#### Caution

The exact alignment of upper and lower valve gasket is very important. Inlet and outlet channels have to be exactly centred. Do not turn inlet and outlet valve after insertion. The copper valve ring could cover outlet channels.

#### Install Inlet / Outlet Valve

- Grease the lower valve gasket slightly and place on the new inlet and outlet valve.  
CAUTION: Observe correct copper valve ring position (centre inlet and outlet channels).
- Place the new inlet and outlet valve straightly into the cylinder (Fig. 3).  
CAUTION: Do not turn the inlet and outlet valve inside the cylinder! The copper valve ring could cover outlet channels!
- Place the upper valve gasket on the inlet and outlet valve.  
CAUTION: Observe the correct paper gasket position (centre inlet and outlet channels). (Fig. 4)  
Note: Valve head screws can be inserted into the valve head to secure the upper valve gasket.
- Refit the valve head and tighten the valve head screws crosswise.

Starting torques:

1st Stage 45 Nm

2nd Stage 25 Nm

The replacement inlet and outlet valves 1st and 2nd stage is now completed.

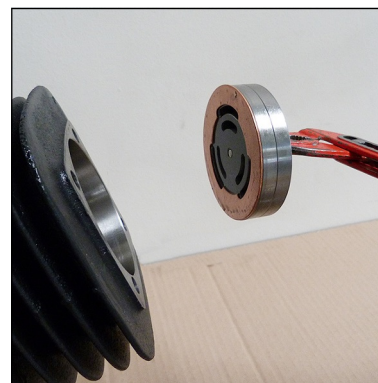

Fig. 3 - Place new inlet and outlet valve straightly into cylinder

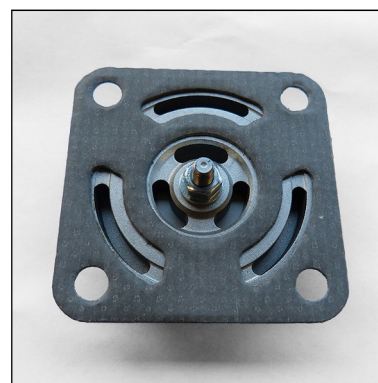

Fig. 4 - Ensure the correct mounting position of the paper gasket

### Replace inlet and outlet valves 3rd and 4th stage



#### Note

The figures of the parts can differ due to the different stages.

#### Replacement inlet and outlet valves as follows:

- Loosen pipe connections
- Loosen valve head screws (Fig. 1)
- Remove lower valve gasket (Fig. 2)
- Dismount inlet and outlet valve (Fig. 3). Observe that the upper valve gasket is also pulled out. (It can still stick inside the cylinder head)
- Check valve head if defective (check centre pin)
- Mount valve gasket on inlet and outlet valve.  
**CAUTION:** Ensure correct mounting position of the upper valve gasket (Fig. 4).
- Insert new inlet and outlet valve into valve head.  
**CAUTION:** Observe correct position between valve centre hole and valve head centre pin.
- Place bottom valve gasket
- Place valve head with the new inlet and outlet valve. Tighten valve head screws crosswise (tightening torque 30 Nm).

#### Replacement inlet and outlet valves complete.

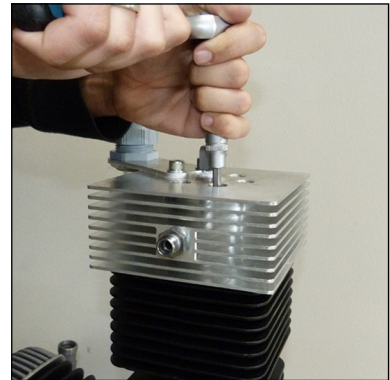

Fig. 1 - Loosen valve head screws

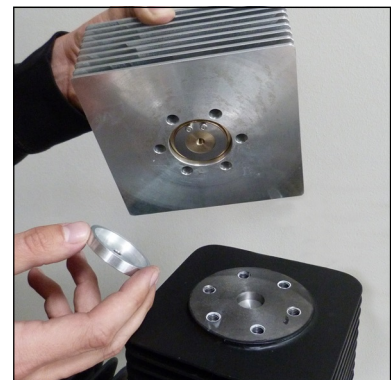

Fig. 2 - Remove lower valve gasket

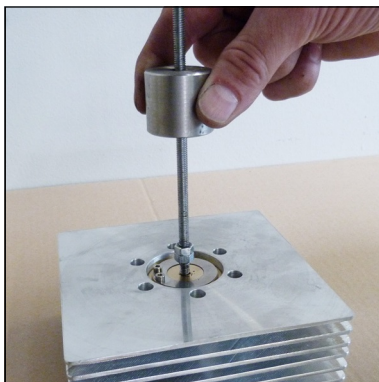

Fig. 3 - Remove inlet and outlet valve

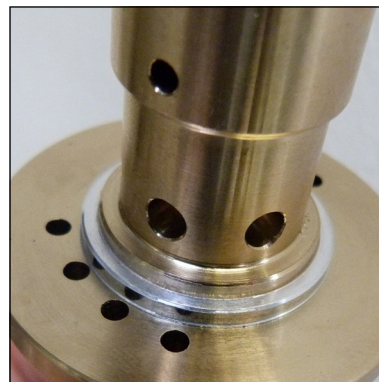

Fig. 4 - Ensure correct mounting position of the upper valve gasket

## MAINTENANCE AND SERVICE

### Safety valves

Every pressure stage is equipped with a separate over pressure safety valve. Safety Valves avoid a non permissible high pressure at the specific pressure stages and limit maximum operation pressure of the compressor.

#### Safety valves are adjusted to:

- 1st Stage: 8 bar
- 2nd Stage: 22 bar
- 3rd Stage: 90 bar
- 4th Stage: max. final pressure

The adjusted blow-off pressure [bar] of the safety valves is indicated on their housings.

All safety valves are factory sealed with special L&W safety seals to avoid manipulation of the limit value settings.

Safety valves with removed seals have to be immediately checked for the prescribed settings and replaced if necessary.

The safety valve of the final stage is furthermore equipped with a knurled screw to be activated once.

Turning the knurled screw clockwise could vent the valve completely and therefore the final filter housing.

During normal operation conditions, the knurled screw has to be turned anti-clockwise up to the upper stop. An integrated circlip avoids complete unscrewing.

If a safety valve blows off, it indicates problems with either inlet or outlet valve of the following stage.



#### Note

Replace defective safety valves immediately!

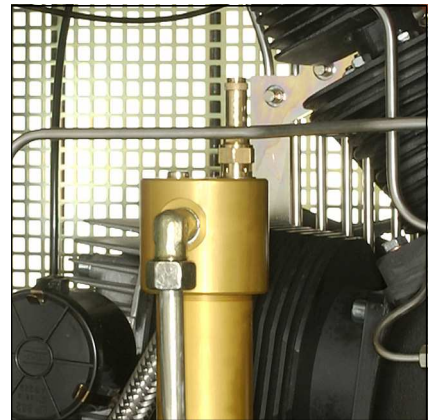

Safety valve 1st stage

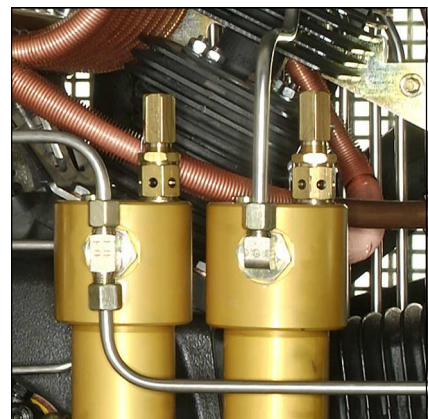

Safety valve 2nd and 3rd stage

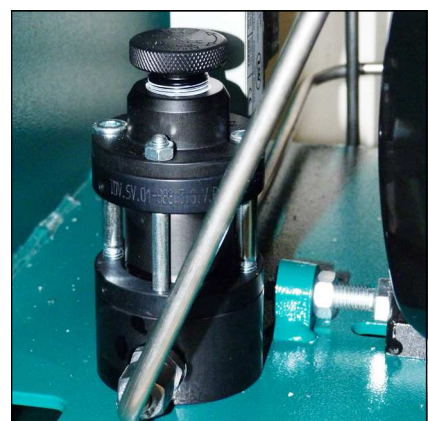

Safety valve 4th stage

A

### Pressure maintaining / non return valve

**Note**

If the adjusted opening pressure of the pressure maintaining valve is higher than the final pressure of the compressor, the final pressure safety valve blows off before pressure maintaining valve opens (final pressure = 0 bar). When valve settings are not clear (e.g. after disassembly / repair), start the adjustment with a low basic setting (turn adjusting screw approx. 3 times in).

A pressure maintaining / non return valve is installed after the mole carbon filter housing. It maintains a pressure of at least 160 bar inside the filter housing - this optimises filter efficiency.

### Pressure maintaining valve

The pressure maintaining valve drains a large part of the water content of the compressed air mechanically by ensuring the minimum outlet pressure. This guarantees optimal drying and purification of the breathing air.

After starting the compressor, the pressure inside the final filter housing constantly increases. The pressure maintaining valve prevents the compressed air from blowing off (final pressure gauge = 0 bar).

When the adjusted opening pressure is reached (160 bar), the purified compressed air flows via pressure maintaining and non return valve to the filling valve.

The value of the opening pressure of the pressure maintaining valve can be read at the final pressure gauge. When opening pressure is reached, the pressure gauge value increases within a few seconds.



Pressure maintaining/non-return valve

### Safety valve test



#### Note

Do not fill any tank during test phase!

#### Safety valve test as follows:

- Depressurise the system.
- Turn the adjusting screw of the final pressure switch one turn clockwise (please see chapter "Final pressure switch", page A-47).
- Start the compressor.
- Watch the final pressure gauge. The safety valve should open when reaching working pressure of the compressor. If not, switch off the unit and take out of service until the safety valve has been replaced.
- Switch off the compressor.
- Turn the adjusting screw of the final pressure switch back (one turn counterclockwise).
- Check the cut-out pressure. Readjust if necessary!

The safety valve test is now completed.



Pressure switch



### Leak test

**Note**

Do not fill any tank during test phase!

**Note**

Two person are recommended for the test!

#### Leak test as follows:

- Close filling valves.
- Start the compressor.
- Press the OFF-switch and hold on the button.
- Verify the compressor for release noises. (A slight hiss of the air inlet filter nozzle can be ignored). If release noises occur, localise blow off position(s).
- Release the OFF-switch.

The leak test is now completed.



OFF-switch

## MAINTENANCE AND SERVICE

---

### Test of pressure equipment

According to the Pressure Equipment Directive 2014/68/EU and TÜV Darmstadt (German supervising authorities).

Subject: pressure equipment with a product permissible operating pressure [bar] x content volume [litres] from 200 up to 1000.

#### Example: Filter housing 1.7 l

Maximum operating pressure: 350 bar

Content volume: 1.7 litres

$350 \text{ bar} \times 1.7 \text{ litres} = 595$

595 is smaller than 1000 -> result: Test is applicable!!

#### Example: Filter housing 2.3 l

Maximum operating pressure: 350 bar

Content volume: 2.3 litres

$350 \text{ bar} \times 2.3 \text{ litres} = 805$

805 is smaller than 1000 -> result: Test is applicable!!

### Pressure equipment from 200 up to 1000 have to be tested as follows:

#### 1. Examination after 5 years by a qualified person or authorized organisations.

Visual inspection, inside and outside.

#### 2. Examination after 10 years by a qualified person or authorized organisations.

Visual inspection, inside and outside.

In addition, a water pressure test is carried out at 1.5 times of the permissible vessel operating pressure.



A

# MAINTENANCE RECORDS



## MAINTENANCE RECORDS

---

### Introduction form for the Operator

**A**

No.	Surname, Name	Date	Place	Signature	Instructor

By adding themselves to this list, the person that signs it confirms having been given a yearly introduction/instruction about the function and operation of the compressor unit. Furthermore, they have been informed about the relevant safety rules and regulations (TRG, DGRL, BetrSichV, GSG, GSGV).



## MAINTENANCE RECORDS

---

### Top up oil, oil change

Date	Operating hours	Oil quantity [l]	Name

A



**MAINTENANCE RECORDS**

---

**Cartridge change**

**A**

Date	Operating hours	Difference	Name



## MAINTENANCE RECORDS

### Maintenance work

**A**

Description	Date, signature



# MAINTENANCE RECORDS

---

## Replaced Parts

Designation	Part number	Date, signature

**A**



## STORAGE

---

### **Conservation / storage of the compressor**

**If the compressor unit is not to be used for an extended period of time, we recommend to carry out the following work before storage time:**

- Run the compressor at 200 bar filling pressure for approximately ten minutes (control the flow with the filling valve to maintain constant pressure).
- Replace compressor oil, open filling valve(s) and run compressor for a few minutes.
- Stop compressor and open drain valves (depending on the compressor type, this may happen automatically). Remove top cap of final filter housing: clean thread, grease o-ring and thread with a food grade grease or silicone grease. Close filter housing.
- Remove intake filter cartridge and undo intake pipes on all valve heads.
- Start compressor unit. Spray a few drops of compressor oil into intake connectors.
- Stop compressor unit and insert intake filter cartridge. Bring intake pipes back in position and fix connections and nuts. Close filling- and drain valves.
- Store the compressor in a cool dry place free from dust and contamination. A dust cover is recommended as long as condensation can be avoided.
- If compressor unit should be stored for a period of more than one year, an oil change is strongly recommended before it's been re-used.
- Fuel driven units only: fill up fuel tank to top level to avoid corrosion.

### **De-conservation, commissioning**

**After the compressor has been stored, the following steps are to be taken:**

- If compressor hasn't been used for longer than 12 months, we strongly recommend an oil change before any use.
- Replace intake filter cartridge and check oil level.
- Clean compressor unit, check for foreign objects. Check condition and tension of V-belts, replace if necessary. Check condition of filling hoses, replace if necessary.
- Secure hoses against whipping and open filling valves and run compressor for approximately 10 minutes.
- Check condition of final filter cartridge, replace if necessary.
- Close filling valves and run compressor up to final pressure.
- Check safety valve relief pressure of final stage and/or pressure switch setting.
- Check all connections and pipe work for leaks.

Once all above steps are completed, compressor unit is now ready for use.

## STORAGE

---

### Transportation instructions

- Parts which need to be dismantled for transport purposes must be carefully replaced and secured before taking into operation.
- The transport may only be carried out by trained personnel.
- For transportation, only use lifting devices and equipment with sufficient lifting power.
- Do not stand or work under suspended loads.
- Also separate from minor relocation machinery / system of any external energy supply. Before recommissioning, reconnect the machine to the mains according to regulations.
- When recommissioning, proceed according to the operating instructions..

### Disposal

The product must be disposed in accordance with national waste disposal regulations and by an appropriate waste disposal company.

### Electric and electronic components

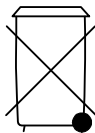

EU-wide regulations for the disposal of electric and electronic appliances which have been defined in the EU Directive 2002/96/EC and in national laws are effective from August 2005 and apply to this device.

Common household appliances can be disposed by using special collecting and recycling facilities. However, as this device has not been registered for household usage, it must not be disposed of through these means.

The device can be returned to L&W. Please do not hesitate to contact us if you have any further questions on this issue.



**ERSATZTEILLISTEN / SPARE PARTS LISTS  
DETAILANSICHTEN / DETAILED VIEWS**

C



## INHALTSVERZEICHNIS / CONTENTS

---

Gehäuse / Housing .....	4
Schalttafel / Control Board .....	6
Kompressorblock / Compressor Block .....	7
Kurbelwelle / Crankshaft .....	11
Kolben 1. Stufe / Piston 1st Stage .....	12
Kolben 2. Stufe / Piston 2nd Stage .....	13
Kolben 3. Stufe / Piston 3rd Stage .....	14
Kolben 4. Stufe / Piston 4th Stage .....	16
Ventil 1. & 2. Stufe / Valve 1st & 2nd Stage .....	18
Ventil 3. & 4. Stufe / Valve 3rd & 4th Stage .....	19
Öl- Wasserabscheider 1.Stufe / Oil- Water Separator 1st Stage .....	21
Öl- Wasserabscheider 2.Stufe / Oil- Water Separator 2nd Stage .....	23
Öl- Wasserabscheider 3.Stufe / Oil- Water Separator 3rd Stage .....	25
Öl- Wasserabscheider Endstufe / Oil- Water Separator Final Stage .....	27
Filtergehäuse 2,3 l / Filter Housing 2.3 ltr .....	29
Kühler 1.Stufe / Cooler 1st Stage .....	31
Kühler 2.Stufe / Cooler 2nd Stage .....	32
Kühler 3. & 4. Stufe / Cooler 3rd & 4th Stage .....	33
Pneumatisches Kondensatventil / Pneumatic Condensate Valve .....	35
Druckhalte- Rückschlagventil / Pressure Maintainig- Non-Return Valve.....	37
Druckschalter / Pressure Switch .....	39
Magnetventile / Solenoid Valves .....	40
Sicherheitsventil / Safety Valve .....	42
Ansaugfilter / Air Intake Filter.....	44
Ölpumpe / Oil Pump .....	45
Ölablassschlauch / Oil Drain Hose .....	47



## INHALTSVERZEICHNIS / CONTENTS

---

Motor / Engine .....	48
Lüfterrad / Cooling Fan .....	50

C

## ERSATZTEILLISTE / SPARE PART LIST

### Gehäuse / Housing

Best.-Nr. / Order No.	Benennung	Description
000498	U-Scheibe A6	Washer A6
000663	Einbaumanometer mit Befestigungsbügel	Press. Gauge c/w fixing strap
000948	Flachkopfzylinderschraube M6x16mm DIN6912 8.8 ZN	Pan Head Bolt M6x16mm DIN6912 8.8 ZN
001029	Zylinderschraube M6x20mm DIN912 8.8 ZN	Allen Bolt M6x20mm DIN912 8.8 ZN
001042	Zylinderschraube M8x30mm DIN912 8.8 ZN	Allen Screw M8x30mm DIN912 8.8 ZN
001047	Zylinderschraube M6x12mm DIN912 8.8 ZN	Allen Bolt M6x12mm DIN912 8.8 ZN
001105	Sechskant Schraube M10X60mm DIN933 8.8 ZN	Hexagon Bolt M10X60mm DIN933 8.8 ZN
001108	Sechskant Schraube M10x80mm DIN933 8.8 ZN	Hexagon Bolt M10x80mm DIN933 8.8 ZN
001156	Stopfmutter M6 DIN985 ZN	Lock Nut M6 DIN985 ZN
001163	Mutter M10 DIN934 ZN	Nut M10 DIN934 ZN
001186	U-Scheibe A10	Washer A10
001194	Federscheibe (Klappdeckel E-Gehäuse)	Wave Spring Washer A12
001677	Griffschale PVC-Schwarz	Plastic Snatch, PVC, black
001683	Schlauchanschlussstück, Alu	Alloy Hose Connector G1/4"
002506	Einbaumanometer 0-250bar	Pressure Gauge 0-250bar
003215	Klemmleiste Frontgitter	Terminal strip front guard
003218	Buchsen Deckelbefestigung	Fixing kit for casing cover
005437	Standfuß, Höhenverstellbar	Foot, Height adjustable Ø80 mm
006164	Befestigungsklammer Griffschale	Clip for Moulded Recess
008192	Schutzgitter, hinten	Rear Grating - zinc plated
009112	Elektrodeckel	Electro Cover
009113	Wartungsdeckel	Maintenance Cover
009832	Kompressorgehäuse LW 570 E II	Housing LW 570 E II standard
009833	Frontgitter, vorne	Front Grating - zinc plated
009834	Klappdeckel	Cover Lid
009902	Steckschlüssel Personenschutzschalter	Key safety switch

**DETAILANSICHT / DETAILED VIEW**

**Baugruppe: Gehäuse / Assembly: Housing**

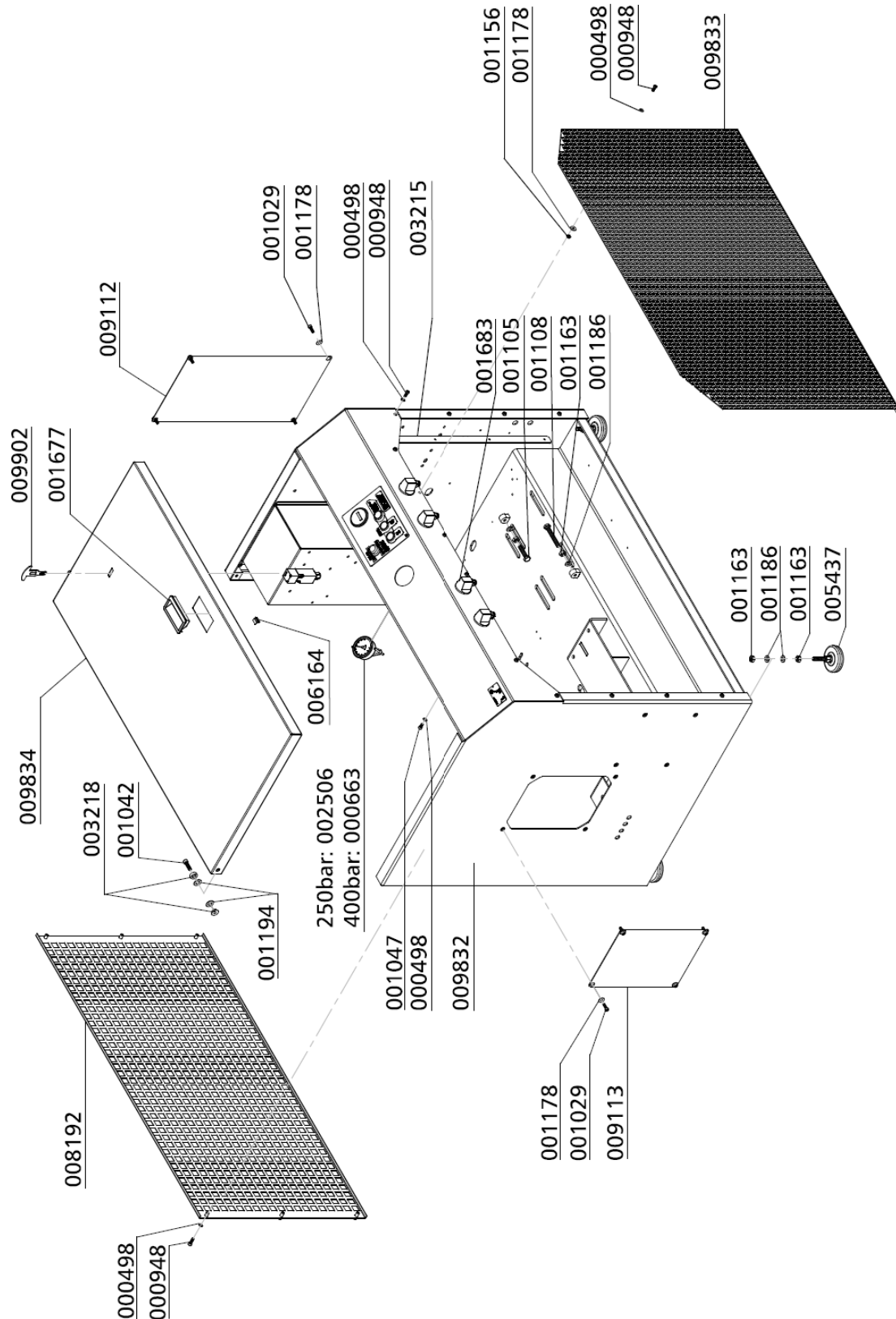

C

## ERSATZTEILLISTE / SPARE PART LIST

### Schalttafel / Control Board

Best.-Nr. / Order No.	Benennung	Description
002089	Betriebsstunderzähler 230V	Hour Counter 230V
002502	Taster blau (komplett inkl. Halterung und Schließer)	Blue button (complete with braket and closing contact)
002504	Taster grün (komplett inkl. Halterung und Schließer)	Green button (complete with braket and closing contact)
003121	Not-Halt Schalter	Emergency switch
008153	Taster rot (komplett inkl. Halterung, Schließer und LED)	Red button (complete with braket, closing contact and LED)

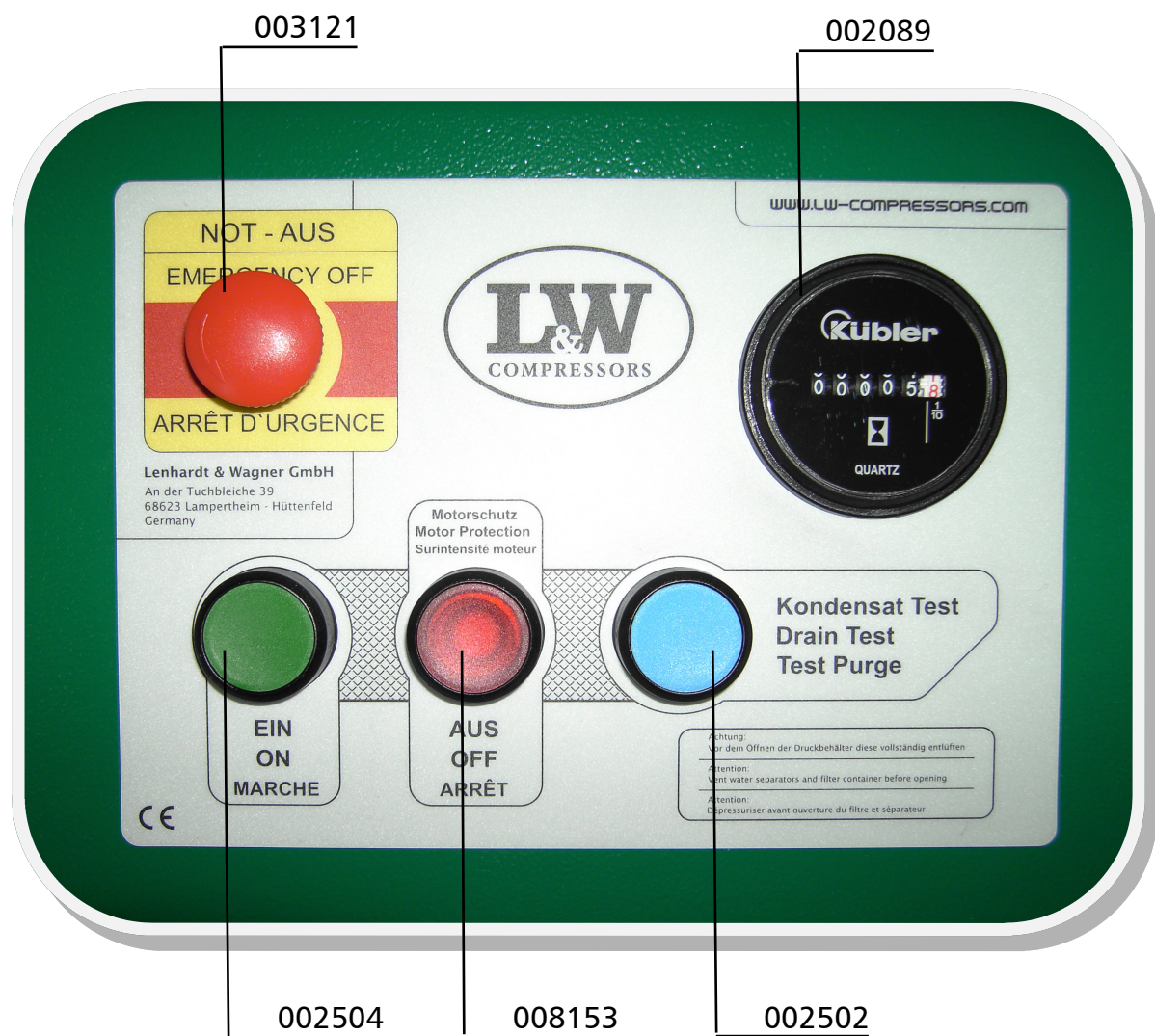





## ERSATZTEILLISTE / SPARE PART LIST

### Kompressorblock / Compressor Block

Best.-Nr. / Order No.	Benennung	Description
000180	Ölschlauchstutzen	Oil hose clip
000239	Kugellager / Hauptlager	Ball Bearing
000240	Dichtung Zylinderflansch / Block	Paper Gasket Cylinder Flange
000241	Dichtung Lagerflansch	Gasket Bearing Flange
000243	Lagerbuchse LW 450	Bearing Bush
000244	Radial-Wellendichtring	Shaft Seal LW 450 / 570
000254	Ventildichtung obere für Ventil 2. Stufe	Upper Valve Gasket, Paper, 2nd
000270	Ventilkopf für Ventil, 2. Stufe	Valve Head for Valve 2nd Stage
000273	Lagerdeckel	Main Bearing Flange
000341	Kurbelgehäuse	Crankcase LW 570
000343	Zylinder 3. Stufe	Cylinder 3rd Stage LW 570
000344	Führungszylinder mit 6x Gewindestift	Guide Cylinder c/w 6x setscrew
000346	Zylinder 4. Stufe	Cylinder 4th Stage
000349	Obere Ventildichtung	Upper Valve Gasket
000350	Untere Ventildichtung für Ventil 1.Stufe	Lower Valve Gasket, 1st Stage
000351	Zylinder 1. Stufe	Cylinder 1st Stage
000353	Sicherungsring, I90 DIN472	Circlip I90
000357	Rohrbogen Ölablass, Ø15mm	Oil Drain Pipe, Ø15 mm
000409	O-Ring Zylinderflansch 1. Stufe	O-Ring - 1st Stage
000410	Pleuel	Conrod, 2nd,3rd & 4th Stage
000411	Pleuel	Conrod 1st Stage
000412	O-Ring, Ölsaugschraube	O-Ring
000413	Sicherungsring, Axialausgleich Wellen	Circlip
000414	Distanzhülse Kühlerhalter	Spacer Cooling Bracket s/s
000498	U-Scheibe A6	Washer A6
000738	Gerade Verschraubung, GE08LRFCX	Straight Connection
000761	Winkelverschraubung, WE08L/1/4"	Elbow Connection
000815	Verschraubung, G15LCFX	Connection
000818	Verschraubung, GE15LRFCX	Connection
000839	Verschlussstopfen, VSTI R3/8" ED A3C	Plug



## ERSATZTEILLISTE / SPARE PART LIST

### Kompressorblock / Compressor Block

Best.-Nr. / Order No.	Benennung	Description
000863	Winkelverschraubung 90°, WE18L-R1/2" A3C	Elbow Connection
000919	Reduzierung, R13/4X1/2CFX	Reducer
000961	Stiftschraube, M8x25mm DIN939	Threaded Stud
001029	Zylinderschraube, M6x20mm DIN912	Allen Bolt
001041	Zylinderschraube, M8x25mm DIN912	Allen Screw
001056	Zylinderschraube, M8x60mm DIN912	Allen Bolt
001058	Zylinderschraube, M8x70mm DIN912	Allen Bolt
001060	Zylinderschraube, M8x80mm DIN912	Allen Bolt
001092	Zylinderschraube, M10x80mm DIN912	Hexagon Bolt
001100	6-kant Schraube, M10x25mm DIN933	Hexagon Screw
001104	6-kant Schraube, M10x50mm DIN933	Hexagon Screw
001133	6-kant Schraube, M12x30mm DIN933	Hexagon Bolt M12x30
001158	Mutter, M8 DIN934	Nut M8
001163	Mutter, M10 DIN934	Nut M10
001181	U-Scheibe A8	Washer A8
001184	Schnorr-Scheibe, S8 N0110	Clamp Washer S8
001186	U-Scheibe A10	Washer A10
001187	U-Scheibe A10	Washer A10
001190	Federring A10	Spring Washer A10
001191	U-Scheibe A12	Washer A12
001274	O-Ring, 50 x 2,5 NBR70	O-Ring
001323	CU-Ring, Ø10 x 16 x 2mm	Copper Seal Ring
001362	Sicherungsring, I82 DIN472	Circlip I72
002362	Winkeleinschraubversch. für Schlauch	Elbow Hose Connection 6 mm
002367	Ventilkopf	Valve Head
002932	Distanzbolzen mit M6 Gewinde	Spacer
003281	Nadellager Pleuel Ø28xØ22x20 mm	Needle bearing, con-rod
003286	Ölschauglas	Oil Level Indicator c/w gasket
003492	Untere Ventildichtung, 2. Stufe	Lower valve gasket, 2nd stage

C



## ERSATZTEILLISTE / SPARE PART LIST

---

### Kompressorblock / Compressor Block

Best.-Nr. / Order No.	Benennung	Description
004367	Oelansaugstopfen	Oil adapter plug
005122	U-Scheibe Kurbelwelle	Washer, crank shaft
005355	Reduziernippel G1/8"IG - G1/8"AG Messing	Reducer Nipple G1/8"-G1/8"
006856	Zylinder 2. Stufe	Cylinder Ø50 mm, 2nd Stage
009650	Ventilkopf 1.Stufe	Valve Head, 1st Stage
009732	Winkerverschraubung, WEE28LROMDCF	Elbow Connection
009853	Gewindestange M6x229mm	Threaded bar

C

**DETAILANSICHT / DETAILED VIEW**

**Kompressorblock / Compressor Block**

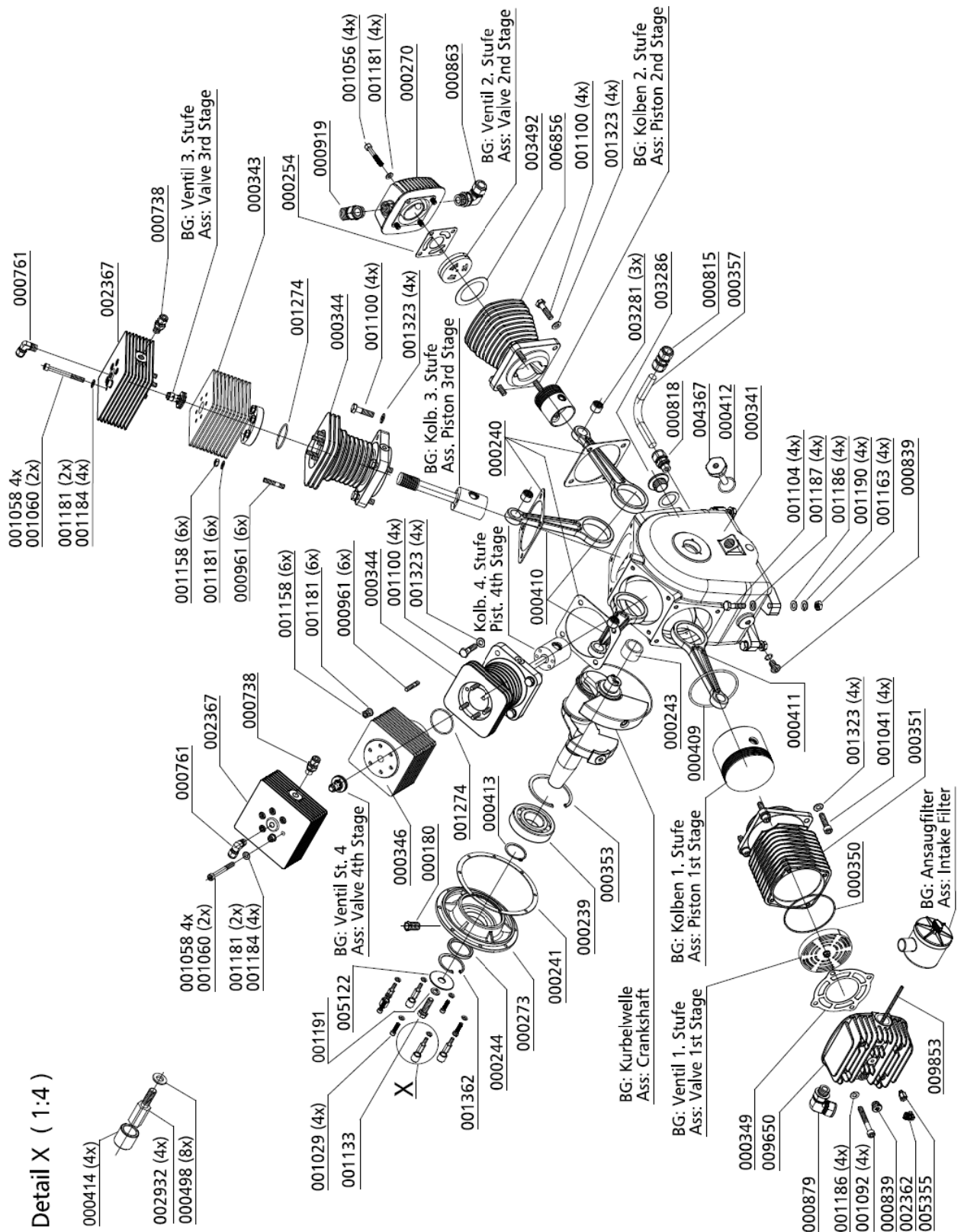

## ERSATZTEILLISTE / SPARE PART LIST

### Kurbelwelle / Crankshaft

Best.-Nr. / Order No.	Benennung	Description
000358	Kurbelwelle, kompl. inkl. Gegengewicht	Crankshaft c/w Counter Weight
000374	Anlaufscheiben Kurbelwelle, 1 Paar	Thrust Washer Crankshaft pair
001184	Schnorr-Scheibe, S8 N0110 ZN	Clamp Washer S8
001207	Passfeder (Kurbelwelle), A8X7X35mm	Woodruff Key
001350	Sicherungsring, A65 DIN471	Circlip A65
004809	Ölpumpenmitnehmerschraube, M6x8mm, 10.9 konischer Schr.kopf	Drive bolt
006775	Zylinderschraube, M10x55mm DIN912	Hexagon Bolt

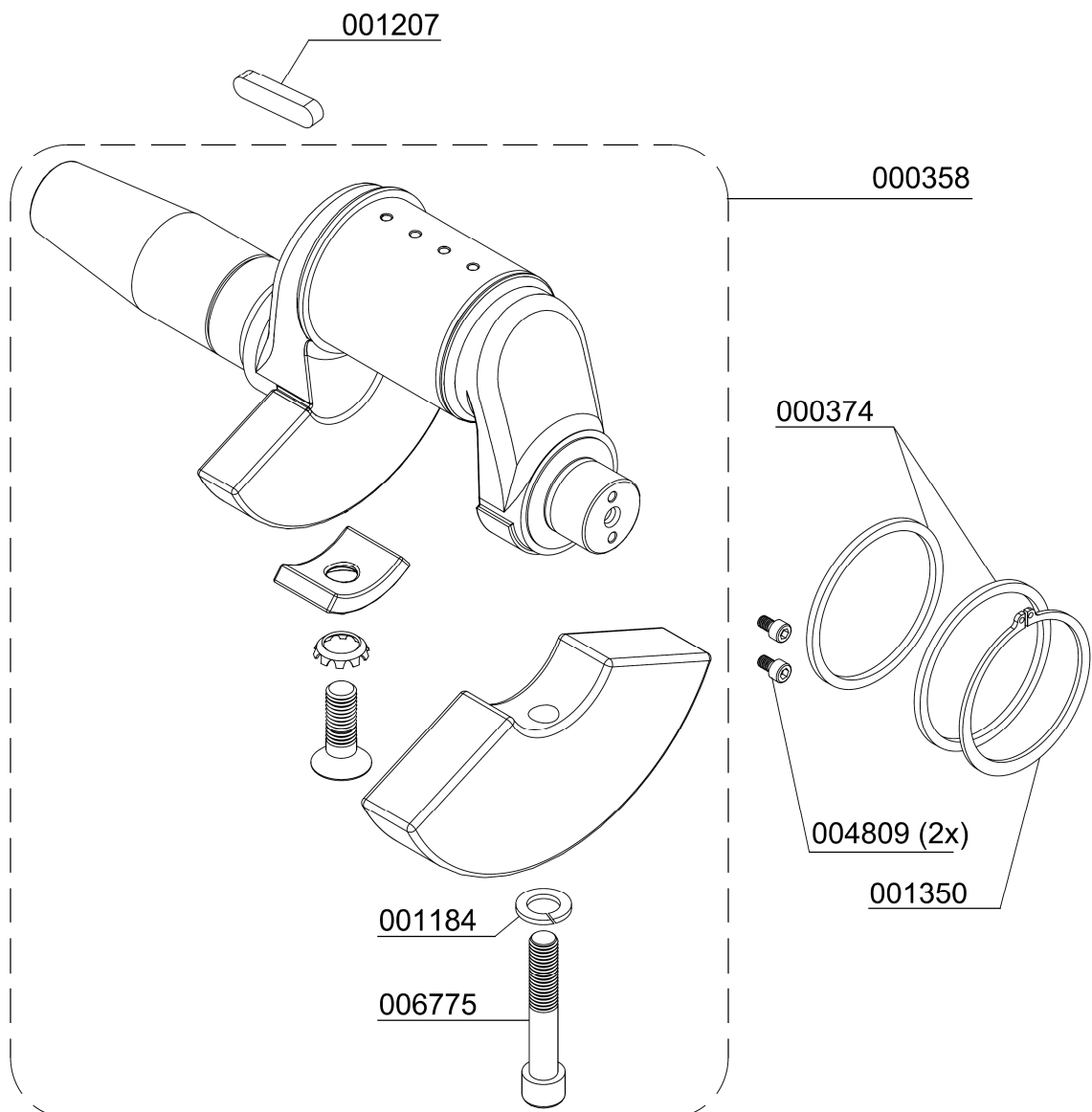

## ERSATZTEILLISTE / SPARE PART LIST

### Kolben 1. Stufe - ø105 / Piston 1st Stage - ø105

Best.-Nr. / Order No.	Benennung	Description
000359	Kolben, 1. Stufe, Ø105mm	Piston 1st Stage Ø105 mm
000360	Kolbenringsatz 1. Stufe Ø105mm	Set Piston Rings 1st Stage Ø105mm
000361	Kolbenbolzen, 1. Stufe Ø25x90 mm	Piston Pin Ø25x90mm
001358	Sicherungsring I 25 DIN472	Circlip I 25 DIN472
005454	Spezialwerkzeug, Spannband	Special Tool, tightening strap

C

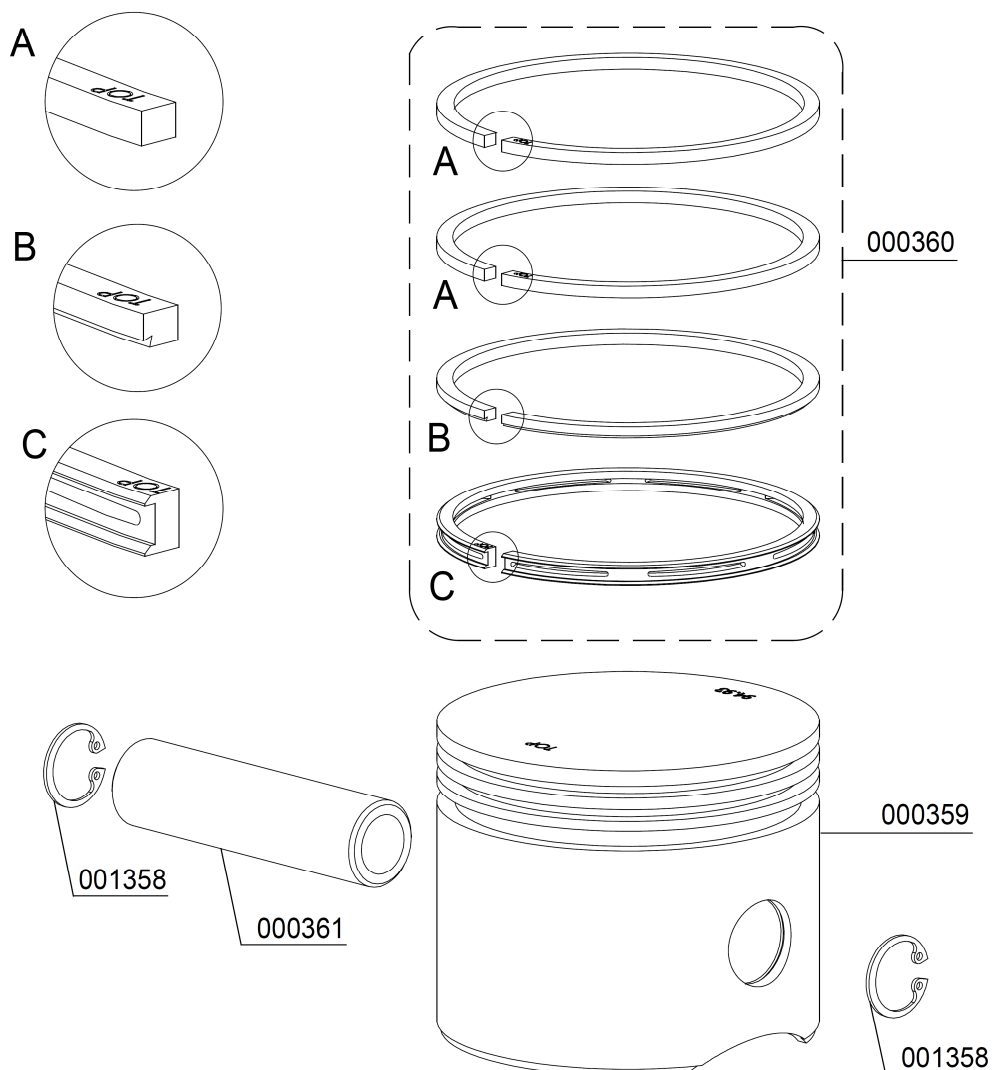

## ERSATZTEILLISTE / SPARE PART LIST

### Kolben 2. Stufe - ø50 / Piston 2nd Stage - ø50

Best.-Nr. / Order No.	Benennung	Description
000362	Kolben, 2. Stufe	Piston 2nd Stage
000363	Kolbenringsatz 2. Stufe, ø50mm	Set Piston Rings 2nd Stage ø50mm
000373	Kolbenbolzen, 2. / 3. / 4. Stufe	Piston Pin, 2nd Stage
001356	Sicherungsring, I 22 DIN472	Circlip I22 DIN472
009397	Spezialwerkzeug Kolbenmontage ø50mm	Special Tool, Splitted bush

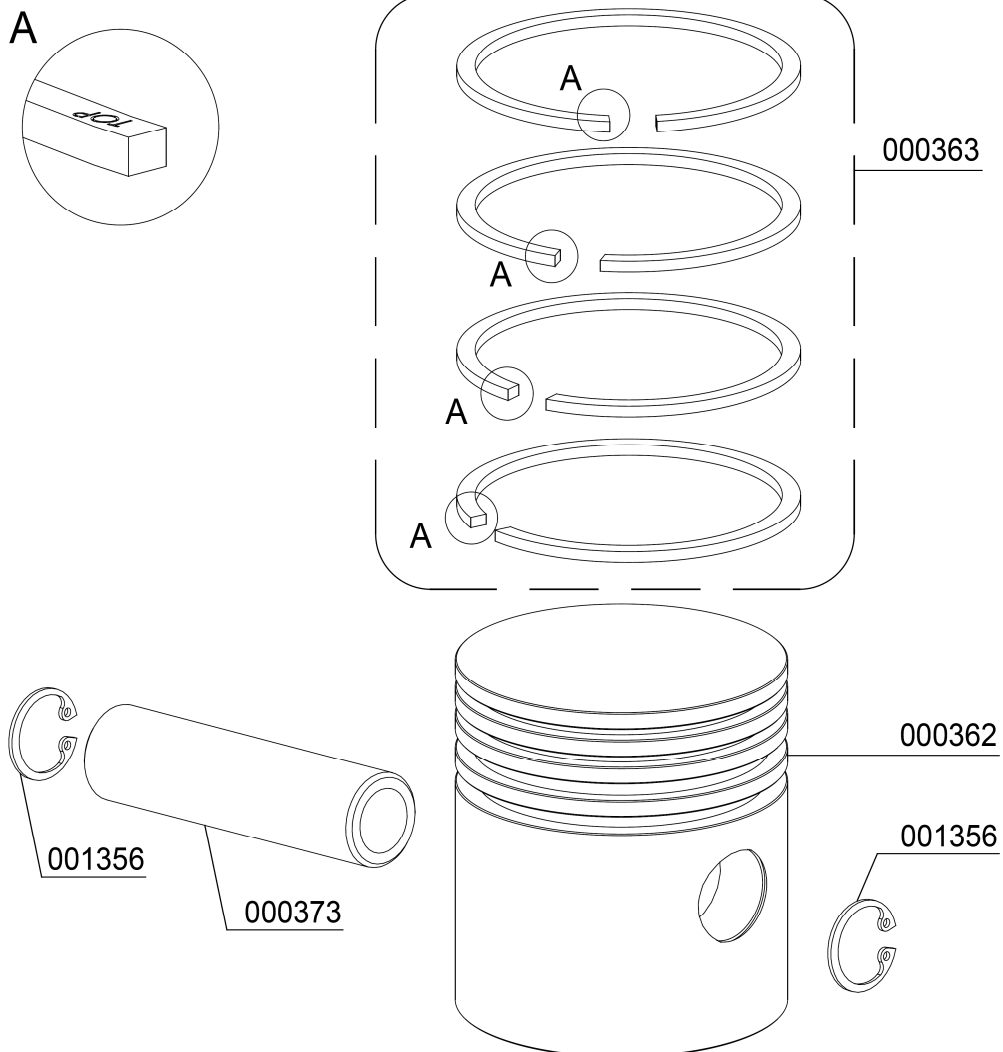



## ERSATZTEILLISTE / SPARE PART LIST

### Kolben 3. Stufe - ø25 / Piston 3rd Stage - ø25

Best.-Nr. / Order No.	Benennung	Description
000365	Kolbenringsatz ø25mm	Set Piston Rings ø25mm
000366	Kolben ø25mm/50mm, 3. Stufe	Piston ø25mm/50mm, 3rd Stage
000373	Kolbenbolzen ø22 x 40mm	Piston Pin ø22 x 40mm
001356	Sicherungsring, I 22 DIN472	Circlip I22 DIN472
005461	Spezialwerkzeug, Halbschalen, ø22mm	Special Tool, Splitted bush
008325	Kolben ø25/50, komplett	Piston ø25/50, complete
008735	Spezialwerkzeug Kolbenringe, 2-teilig ø25 mm Montagezange & Hülse	Special Tool Piston Rings ø25

Spezialwerkzeug Kolbenmontage / Special Tool Piston fitting	Spezialwerkzeug Kolbenringmontage / Pistonring fitting Tool
005461	008735



**DETAILANSICHT / DETAILED VIEW**

**Kolben 3. Stufe - ø25 / Piston 3rd Stage - ø25**

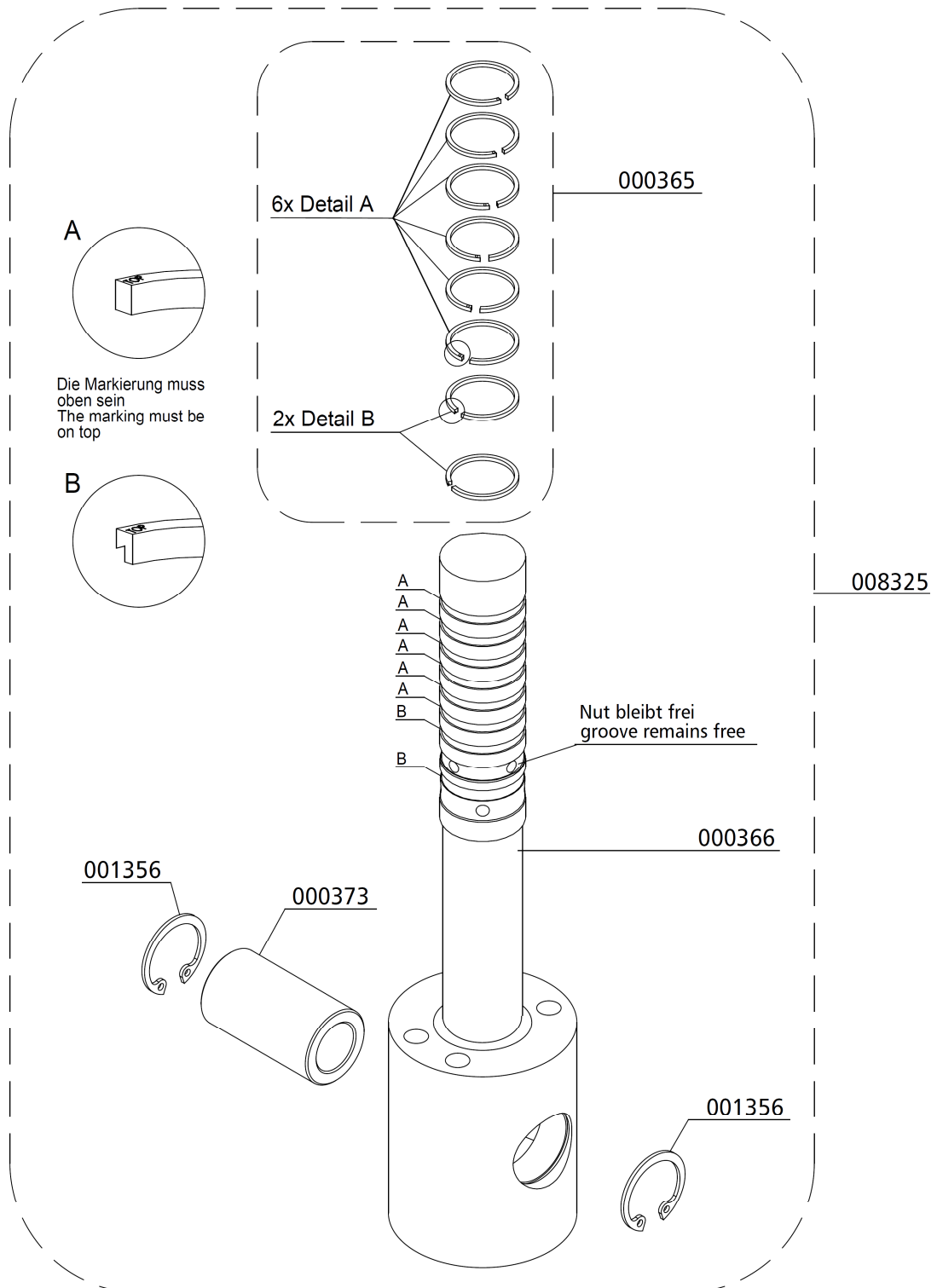

Spezialwerkzeug Kolbenmontage: 005461  
 Special tool Piston fittings : 005461

Spezialwerkzeug Kolbenringmontage : 008735  
 Special tool Piston rings fitting : 008735



## ERSATZTEILLISTE / SPARE PART LIST

### Kolben 4. Stufe - ø14 / Piston 4th Stage - ø14

Best.-Nr. / Order No.	Benennung	Description
000367	Kolbenringsatz ø14mm	Set Piston Rings ø14mm
000368	Kolben ø14mm/50mm, komplett	Piston ø14mm/50mm, complete
000373	Kolbenbolzen ø22 x 40 mm	Piston Pin ø22 x 40 mm
001356	Sicherungsring I 22 DIN472	Circlip I 22 DIN472
005458	Spezialwerkzeug, 2 Halbschalen für Montage Kolben ø14mm	Special Tool, Splitted bush
005459	Spezialwerkzeug, Montagehülse für Montage Kolbenringe ø 14mm	Special Tool, Fitting tool
005460	Spezialwerkzeug, Montagezange für Montage Kolbenringe ø 14mm	Special Tool, Pliers
007432	Kolben ø14mm/50mm	Piston ø14mm/50mm

C

Spezialwerkzeug Kolbenmontage / Special Tool Piston fitting	Spezialwerkzeug Kolbenringmontage / Pistonring fitting Tool
005458	005459 / 005460

**DETAILANSICHT / DETAILED VIEW**

**Kolben 4. Stufe - ø14 / Piston 4th Stage - ø14**

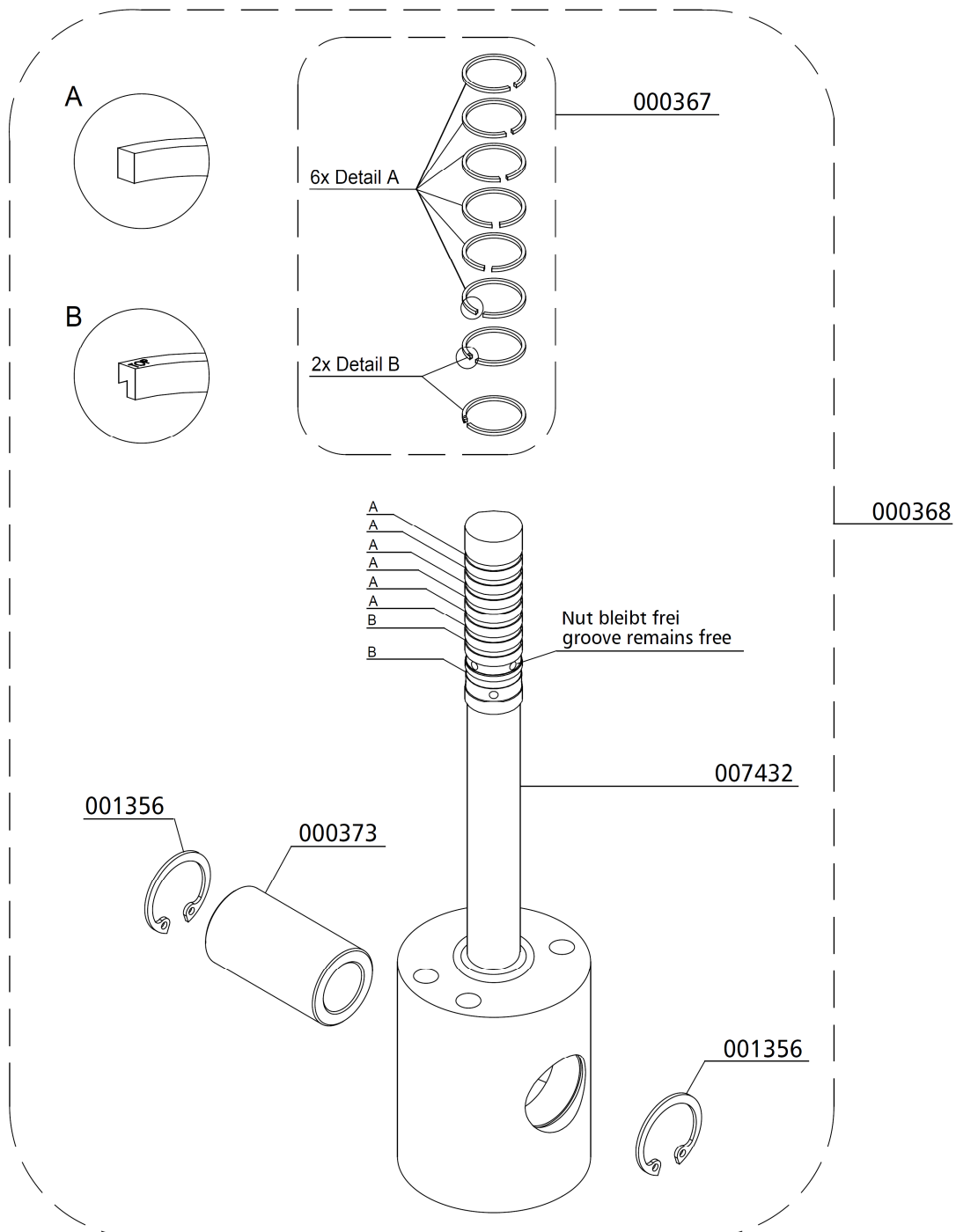

C

Spezialwerkzeug Kolbenmontage: 005458  
 Special tool Piston fittings : 005458

Spezialwerkzeug Kolbenringmontage : 005459 / 005460  
 Special tool Piston rings fitting : 005459 / 005460

## ERSATZTEILLISTE / SPARE PART LIST

### Ventil 1. & 2. Stufe / Valve 1st & 2nd Stage

Best.-Nr. / Order No.	Benennung	Description
000256	Saug- Druckventil, 2. Stufe	In-&Outlet Valve, 2nd Stage
000369	Saug- Druckventil, 1. Stufe	In-&Outlet Valve, 1st Stage

000256  
Ventil 2.Stufe  
Valve 2nd Stage

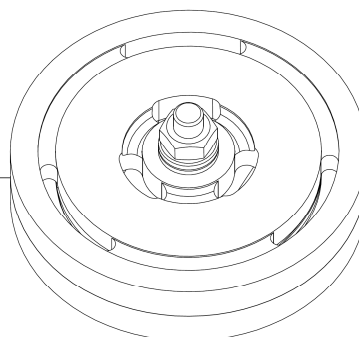

000369  
Ventil 1.Stufe  
Valve 1st Stage

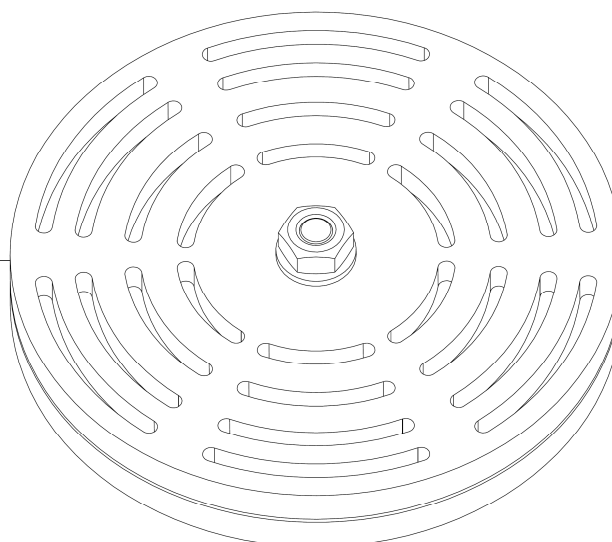



## ERSATZTEILLISTE / SPARE PART LIST

---

### Ventil 3. + 4. Stufe / Valve 3rd + 4th Stage

Best.-Nr. / Order No.	Benennung	Description
000533	Ventildichtung unten, Saug-& Druckventil	Lower Valve Gasket
000534	Ventildichtung, Saug- & Druckventil	Lower Valve Gasket 4th Stage
000540	Dichtring / Dichtung, 3. / 4. Stufe	Upper Alloy Seal Ring 3rd/4th
010346	Saug-/Druckventil, 3. Stufe, komplett	In-/Outlet Valve, 3rd Stage
010347	Saug-/Druckventil, 4. Stufe, komplett	In-/Outlet Valve, 4th Stage

C

**ERSATZTEILLISTE / SPARE PART LIST**

**Ventil 3. + 4. Stufe / Valve 3rd + 4th Stage**

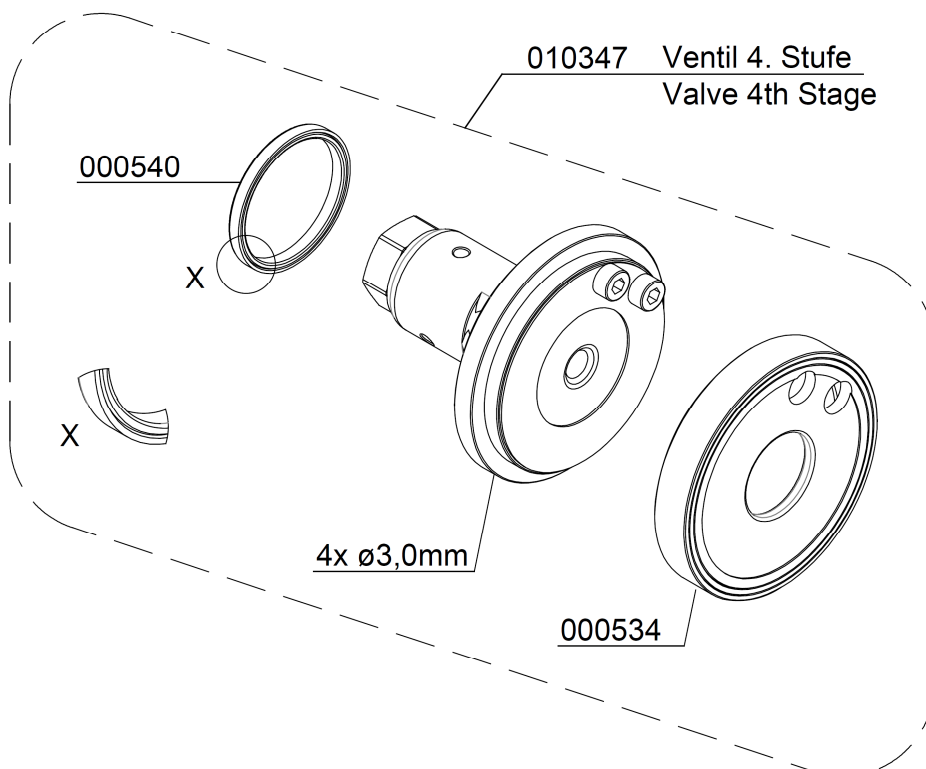
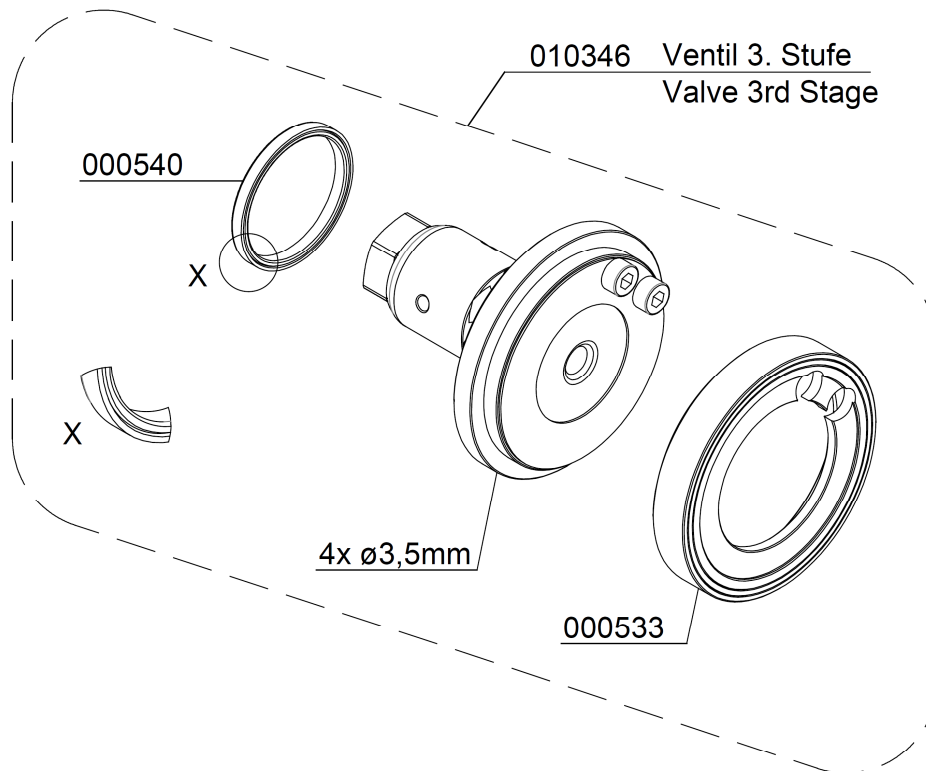

C



## ERSATZTEILLISTE / SPARE PART LIST

### Öl- / Wasserabscheider 1. Stufe / Oil- / Water Separator 1st Stage

Best.-Nr. / Order No.	Benennung	Description
000172	Prallscheibe	Mounting plate water separator
000173	Sinterfilter Wasserabscheider	Sintered Filter Water separat.
000174	Drallscheibe, Wasserabscheider	Twist Disk, Water separator
000176	Stiftschraube, Wasserabscheider 2. Stufe	Treaded Stud
000177	Trichter f. Wasserabscheider	Water Deflector
000220	Sicherheitsventil G3/8" 8 bar	Safety Valve G3/8" 8 bar
000379	Wasserabscheider - Oberteil G1/2" IG	Top Water Separator 1/2"female
000391	U-Sit Ring	Seal Ring U-Sit
000564	Öl-/Wasserabscheider - Druckbehälter	Container Water Separ.
000820	Winkel Verschraubung WE15LRCTX	Straight Connection
000837	Verschlussstopfen, VSTI 1/8" ED	Plug
000838	Verschlussstopfen, VSTIR1/4EDA3C	Plug
000863	Winkelverschraubung WE18L-R1/2" A3C	Elbow Connection
001133	6-kant Schraube M12x30	Hexagon Bolt M12x30
001191	U-Scheibe A12	Washer A12
001192	Federring A12	Spring Washer A12
001272	O-Ring 47 x 3 NBR70	O-Ring Water separator
002914	Sinterfilter für Wasserabscheidersockel	Sintered filt. water sep. base
003110	Sockel Wasserabscheider	Water separator base
003347	Unterer Ring, Wasserabscheider 120 bar	Base Ring, water separator
003348	Filterverschraubung für Wasserabscheider	Connec. for sintered filter
006845	Stopfmutter Edelstahl	Lock Nut M6 s/s
010689	Öl-/ Wasserabscheider kompl. Einheit , ohne SV	Oil-/ Water Separator (comp. unit)

**ERSATZTEILLISTE / SPARE PART LIST**

**Öl- / Wasserabscheider 1. Stufe / Oil- / Water Separator 1st Stage**

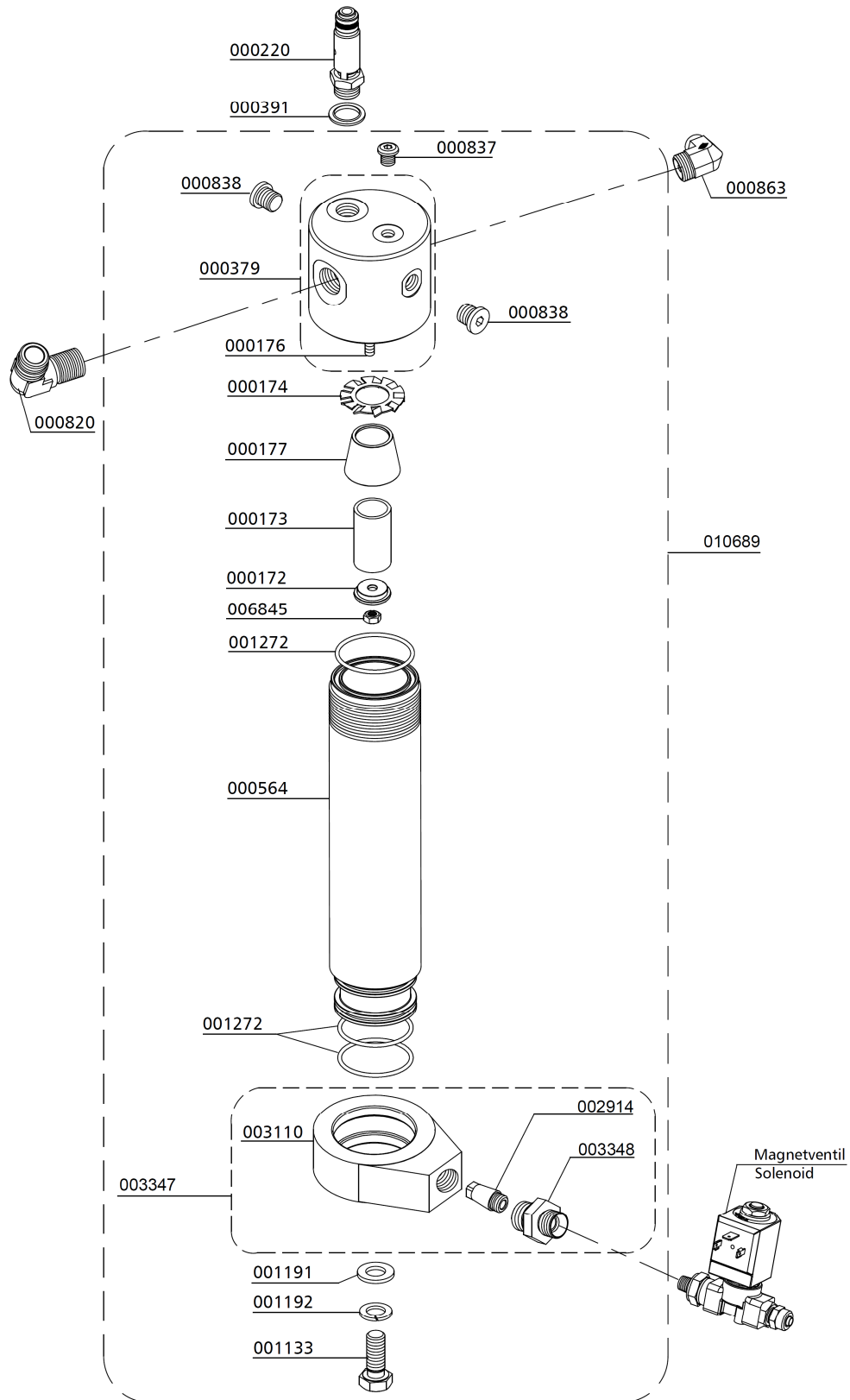

C



## ERSATZTEILLISTE / SPARE PART LIST

### Öl- / Wasserabscheider 2. Stufe / Oil- / Water Separator 2nd Stage

Best.-Nr. / Order No.	Benennung	Description
000172	Prallscheibe	Mounting plate water separator
000173	Sinterfilter Wasserabscheider	Sintered Filter Water separat.
000174	Drallscheibe, Wasserabscheider	Twist Disk, Water separator
000176	Stiftschraube, Wasserabscheider 2. Stufe	Treaded Stud
000177	Trichter f. Wasserabscheider	Water Deflector
000379	Wasserabscheider - Oberteil G1/2" IG	Top Water Separator 1/2"female
000380	Sicherheitsventil G3/8" 22 bar	Safety Valve G3/8" 22 bar
000391	U-Sit Ring	Seal Ring U-Sit
000564	Öl-/Wasserabscheider - Druckbehälter	Container Water Separ.
000810	Winkel Verschraubung, WE12LR1/2CFX	Elbow Connection
000837	Verschlussstopfen, VSTI 1/8" ED	Plug
000838	Verschlussstopfen, VSTIR1/4EDA3C	Plug
000866	Verschraubung, GE18LRFCX	Connection
001133	6-kant Schraube M12x30	Hexagon Bolt M12x30
001191	U-Scheibe A12	Washer A12
001192	Federring A12	Spring Washer A12
001272	O-Ring 47 x 3 NBR70	O-Ring Water separator
002914	Sinterfilter für Wasserabscheidersockel	Sintered filt. water sep. base
003110	Sockel Wasserabscheider	Water separator base
003347	Unterer Ring, Wasserabscheider 120 bar	Base Ring, water separator
003348	Filterverschraubung für Wasserabscheider	Connec. for sintered filter
006845	Stopfmutter Edelstahl	Lock Nut M6 s/s
010689	Öl-/ Wasserabscheider kompl. Einheit , ohne SV	Oil-/ Water Separator (comp. unit)

**ERSATZTEILLISTE / SPARE PART LIST**

**Öl- / Wasserabscheider 2. Stufe / Oil- / Water Separator 2nd Stage**

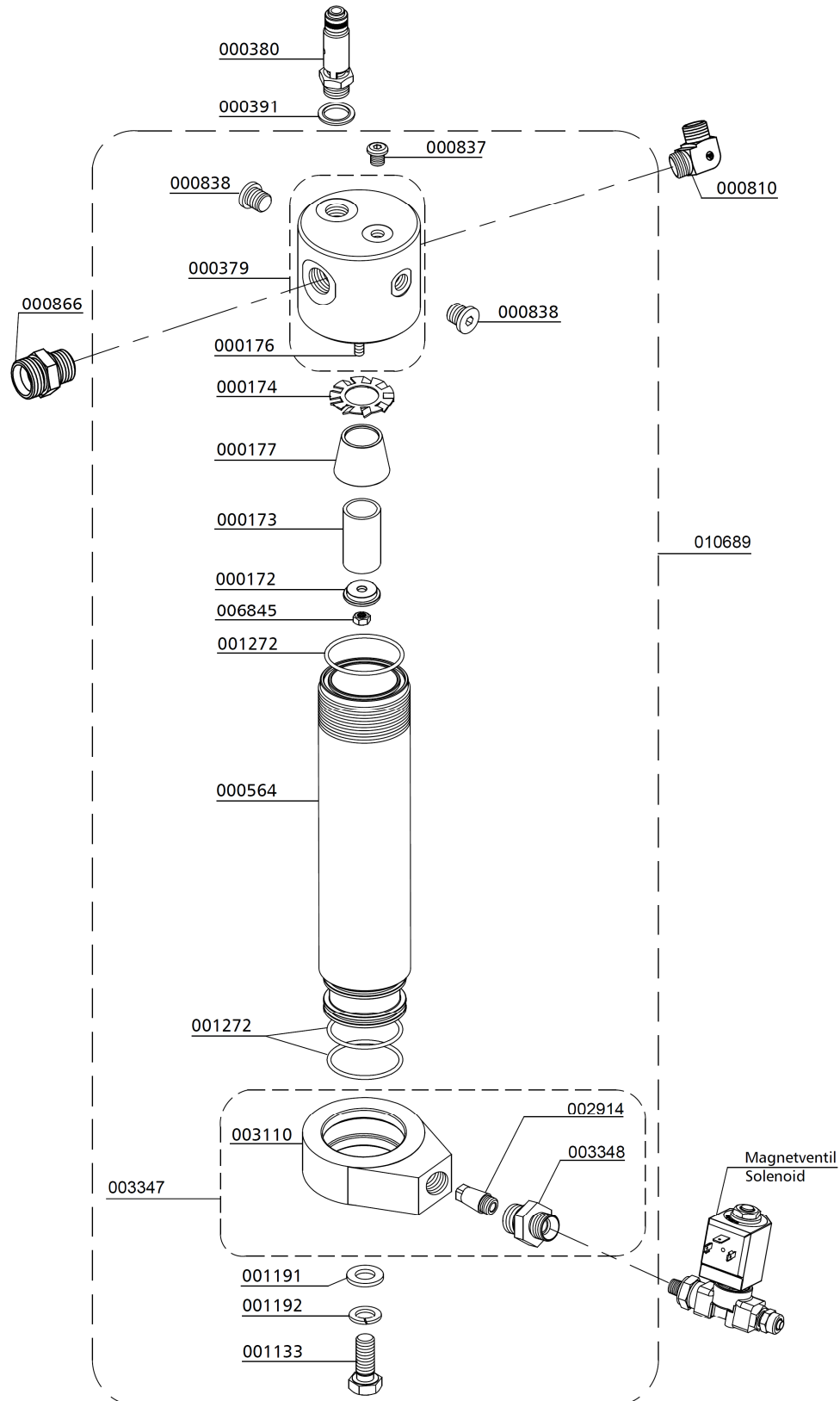

C

**Öl- / Wasserabscheider 3. Stufe / Oil- / Water Separator 3rd Stage**

Best.-Nr. / Order No.	Benennung	Description
000172	Prallscheibe	Mounting plate water separator
000173	Sinterfilter Wasserabscheider	Sintered Filter Water separat.
000174	Drallscheibe, Wasserabscheider	Twist Disk, Water separator
000176	Stiftschraube, Wasserabscheider 2. Stufe, M6, Länge: 78mm	Treaded Stud
000177	Trichter f. Wasserabscheider	Water Deflector
000379	Wasserabscheider - Oberteil G1/2" IG	Top Water Separator 1/2"female
000381	Sicherheitsventil G3/8"	Safety Valve G3/8" 90 bar
000391	U-Sit Ring, Ø16,7XØ24X1,5mm	Seal Ring U-Sit
000564	Öl-/Wasserabscheider - Druckbehälter	Container Water Separ.
000738	Gerade Verschraubung, GE08LRCFX	Straight Connection
000761	Winkelverschraubung, WE08LRA3CX	Elbow Connection
000837	Verschlussstopfen, VSTI 1/8" ED	Plug
000838	Verschlussstopfen, VSTIR1/4EDA3C	Plug
000921	Reduzierung	Reducer
001133	6-kant Schraube M12x30	Hexagon Bolt M12x30
001191	U-Scheibe A12	Washer A12
001192	Federring A12	Spring Washer A12
001272	O-Ring O-Ring 47 x 3 NBR70	O-Ring Water separator
002914	Sinterfilter für Wasserabscheidersockel	Sintered filt. water sep. base
003110	Sockel Wasserabscheider	Water separator base
006845	Stopfmutter Edelstahl, M6 DIN985	Lock Nut M6 s/s
009693	Filterverschraubung für Wasserabscheider	Connec. for sintered filter

**ERSATZTEILLISTE / SPARE PART LIST**

**Öl- / Wasserabscheider 3. Stufe / Oil- / Water Separator 3rd Stage**

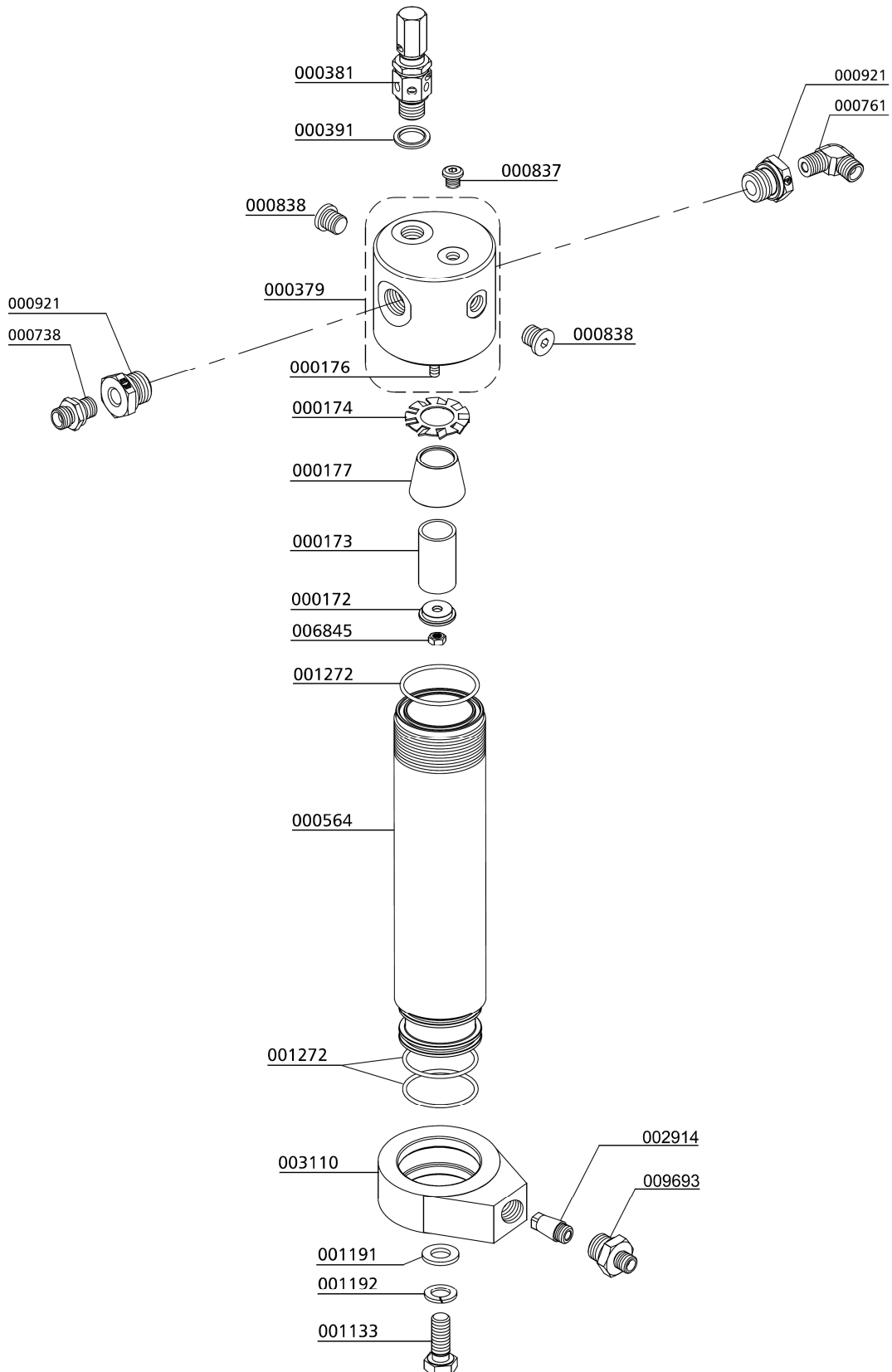

C

**Öl- / Wasserabscheider Endstufe / Oil- / Water Separator Final Stage**

Best.-Nr. / Order No.	Benennung	Description
000175	Deckel, Wasserabscheider	Cap
000178	Schalldämpfer G1/2"	Silencer G1/2"
000182	Endstufe Wasserabscheider (PN 15 bar)	Water Separator c/W bracket
000183	Wasserabweiser	Filter Protecor
000184	Sinterfilter Wasserabscheider	Siltered Filter, Oil Filter
000185	Haltehalter	Plate
000186	Drallscheibe	Twist Disk
000395	Blechhalter Kondensatabscheider	Bracket water separator
000497	Mutter M6	Nut M6
000498	Unterlegscheibe, A6 DIN 125	Washer A6
000761	Verschraubung WE 08 PLR CFX	Connection
000765	Schneidring PSR 08 LX	<i>Olive Seal 8mm</i>
000766	Mutter 8L	Nut 8L
000921	Reduzierung 1/2"-1/4"	Reducer 1/2"-1/4"
000948	Flachkopfschraube M6x16mm DIN6912 8.8 ZN	Pan Head Bolt M6x16mm DIN6912 8.8 ZN
001027	Zylinderschraube M6x30	Allen Bolt M6x30
001156	Stopfmutter M6 DIN985 ZN	Lock Nut M6
001294	O-Ring 68x3 NBR90	O-Ring 68x3
001431	Befestigungsring Wasserabscheider LW 450	Lock Ring Water Separator
002466	Kondensatbehälter für Abscheider	Condensate bowl
002563	Wasserabscheider Oberteil PN 15 bar	Water Separator, upper comp. PN15 bar
005154	Endstufe Wasserabscheider (PN 15 bar) (kompl. montiertes Oberteil)	Water Separator w/o bowl & bra
005856	Winkelschraubverschraubung 8 mm G1/8" - 8 mm, inkl. Mutter	Elbow Hose Connection 8 mm G1/8" - 8 mm, inkl. Lock nut

**DETAILANSICHT / DETAILED VIEW**

**Öl- / Wasserabscheider Endstufe / Oil- / Water Separator Final Stage**

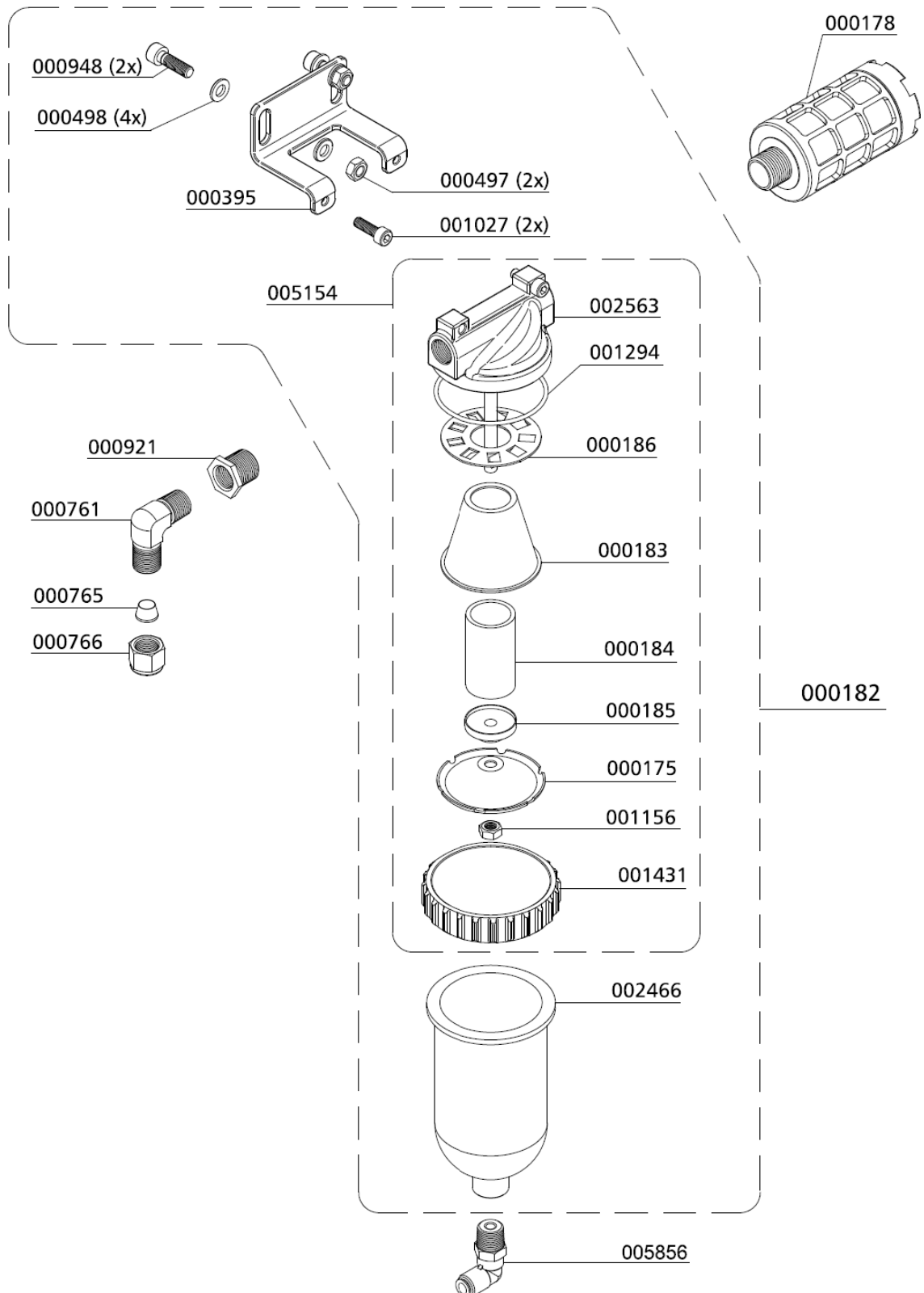

C



## ERSATZTEILLISTE / SPARE PART LIST

### Filtergehäuse 2,3 l / Filter Housing 2.3 ltr

Best.-Nr. / Order No.	Benennung	Description
000003	Filterpatrone 2,3 Liter	Filter Cartridge 2.3 ltr BA
000383	Messing Adapter für Filterpatrone	Brass Filter Adapter
000384	Düse für Filtergehäuse	Jet Filter Housing
000738	Verschraubung, GE08LRFCFX	Connection
000761	Winkerverschraubung, WE08LRA3CX	Elbow Connection
001159	Stopfmutter, M8 DIN985	Lock Nut M8
001181	U-Scheibe A8	Washer A8
001285	Stützring, Filtergehäuse	Back-up Ring Filter Housing
001287	O-Ring, Filtergehäuse, 62,87 x 5,33 NBR90	O-Ring filter housing
002147	Haltebügel für Filtergehäuse (ES)	U-Clamp for filter housing ES
002426	Filtergehäuse, kompl.	Filter housing
005190	Filterschlüssel 1,7 & 2,3 Liter Behälter	Filter key for 1,7 & 2,3 Liter
005244	O-Ring 16 x 2,5 NBR90	O-Ring
012457	Halteschale Endfiltergehäuse 350/420 bar	Spacer Bracket Filter Housing

C

**ERSATZTEILLISTE / SPARE PART LIST**

**Filtergehäuse 2,3 l / Filter Housing 2.3 ltr**

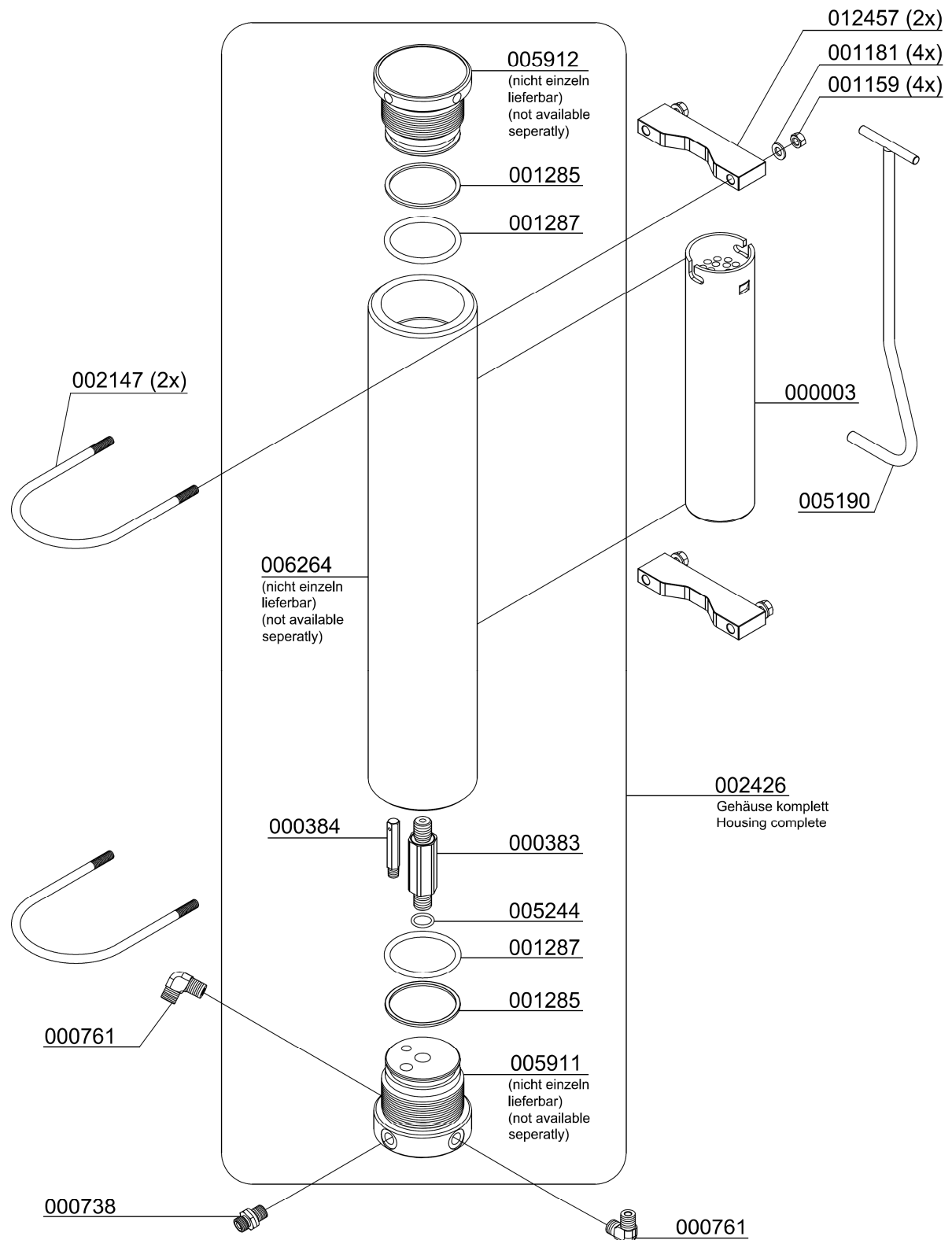

C



**Kühler 1. Stufe / Cooler 1st Stage**

Best.-Nr. / Order No.	Benennung	Description
000866	Verschraubung	Connection
001100	6-kant Schraube	Hexagon Screw
001186	U-Scheibe A10	Washer A10
001190	Federring A10	Spring Washer A10
002013	Kühler 1. Stufe	Cooler 1st Stage
009824	Gerade Verschraubung	Straight Connection

C

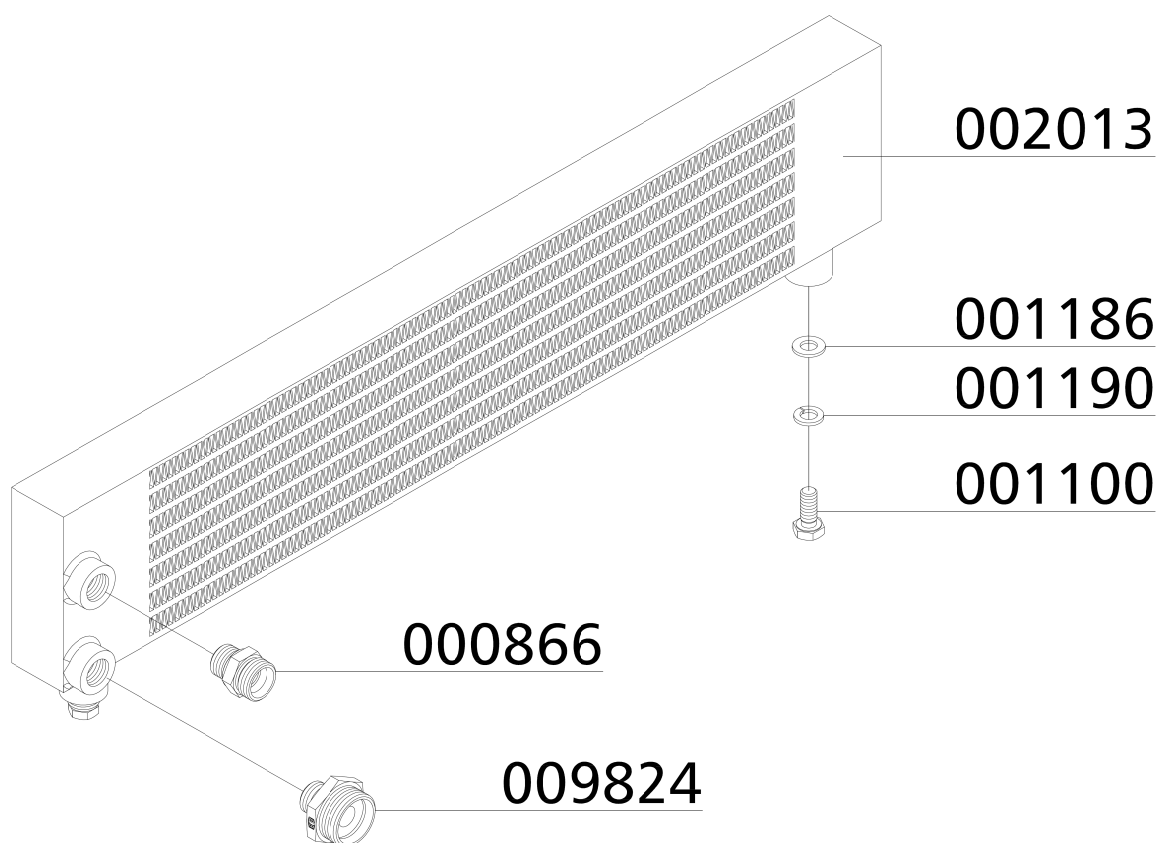

**Kühler 2. Stufe / Cooler 2nd Stage**

Best.-Nr. / Order No.	Benennung	Description
000331	Halteblech Kühlspirale 2. Stufe	Bracket 2nd Stage Cooling Pipe
000332	Wärmetauscher 2. Stufe, Cu	Heat Exchanger 2nd Stage
000333	Klemmschiene Wärmetauscher, Halteschiene	Clamp Bar for Heat Exchanger
000334	PVC Schlauch, transparent	PVC Hose for Bracket
001058	Zylinderschraube	Allen Bolt
001159	Stopfmutter	Lock Nut M8
001181	U-Scheibe A8	Washer A8

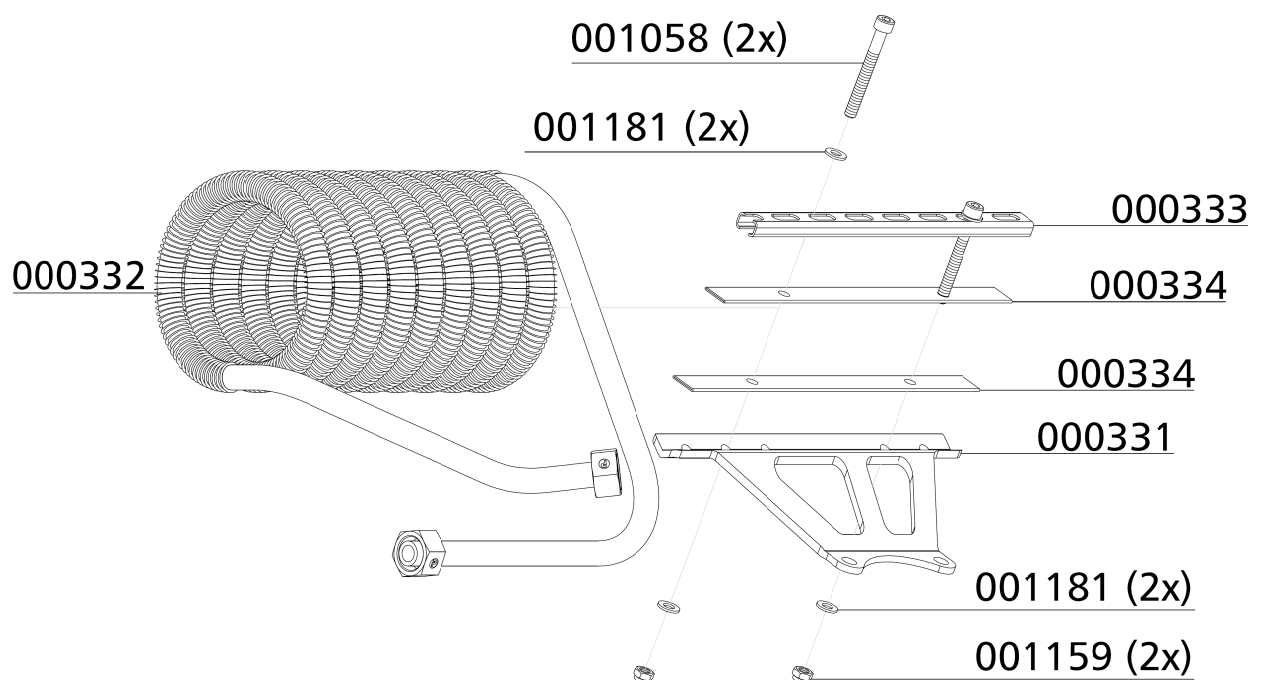



## ERSATZTEILLISTE / SPARE PART LIST

### Kühler 3. & 4. Stufe / Cooler 3rd & 4th Stage

Best.-Nr. / Order No.	Benennung	Description
000209	Öleinfüllstopfen	Oil Filler Plug
000312	Kühlerhalter links, m. Gewindenieten	Bracket c/w threaded rivets
000313	Kühlerhalter rechts, m. Gewindenieten	Bracket c/w threaded rivets
000314	Halteblech Ölschlauch	Bracket Oil Hose
000315	Kühlrohr links ohne Halter u. Klemmen	Cooling Pipe 4th Stage
000316	Kühlrohr rechts ohne Halter u. Klemmen	Cooling Pipe 3rd Stage
000498	U-Scheibe A6	Washer A6
000509	Zylinderschraube M6x35 mm	Allen Bolt
000629	Doppelschelle 2 x 8mm 1 Paar	Pipe Clamp 2x8mm - 1 pair
000638	Doppelschelle 2 x 8 mm 1 Paar	Pipe Clamp 2x8mm - 1 pair
000735	Verschraubung G08LCFX	Connection
001013	Zylinderschraube M6x45mm DIN912	Allen Bolt
001178	U-Scheibe A6	Washer A6
002358	Schnellkupplung gerade, G1/8"-6mm	Quick rel. coupling, straight
005134	PG Verschraubung PG21	PG21 Connection

C

# ERSATZTEILLISTE / SPARE PART LIST

## Kühler 3. & 4. Stufe / Cooler 3rd & 4th Stage

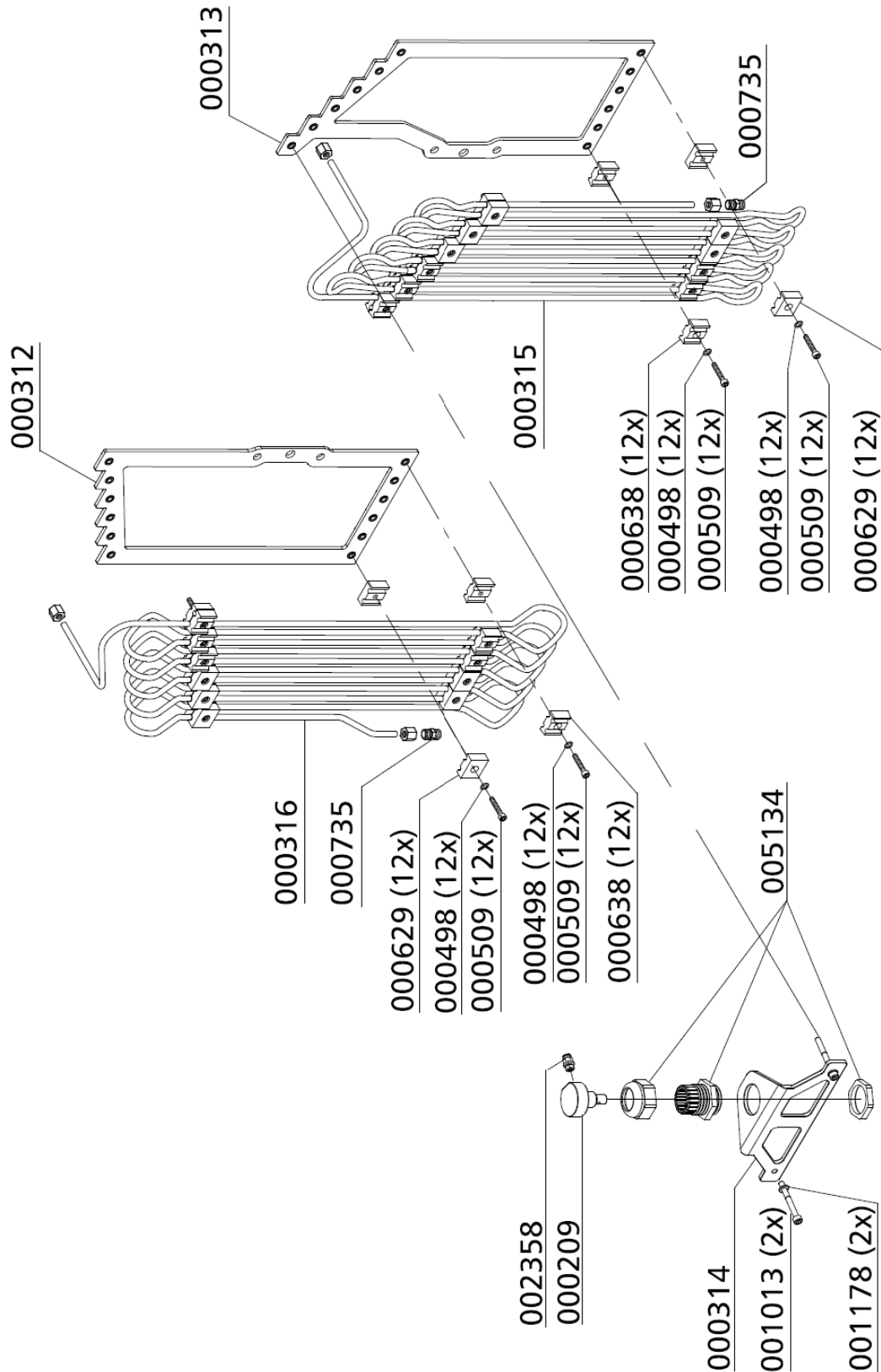



## ERSATZTEILLISTE / SPARE PART LIST

### Pneum. Kondensat-Ablassventil / Pneumatic Condensate Valve

Best.-Nr. / Order No.	Benennung	Description
000188	Sinterfilter, pneum. Kondensatventil	Sintered Filter
000190	O-Ring 10 x 2,5 NBR90	O-Ring 10 x 2,5 NBR90
000191	Steuerkolben, pneum. Kondensatventil	Piston
000498	U-Scheibe A6	Washer A6
000710	Gerade Verschraubung GE06L	Straight Connection GE06L
000737	Verschraubung GE08LR1/8CFX	Elbow connection GE08LR1/8CFX
001011	Zylinderschraube M6x60mm	Allen Bolt
005325	Verschraubung GE 08L R1/4" .71	Connection GE 08L R1/4" .71
006614	O-Ring 20x2 NBR90	O-Ring 20x2 NBR90
011064	Pneum. Kondensatablassventil, PN 420 bar, Einlass Ø3,0 mm	Pneumatic Condensate Valve, PN 420 bar, intake Ø3,0 mm
011065	Gehäuse, pneum. Kondensatventil	Housing PCV
011066	Düsenschraube, pneum. Kondensatventil, Standard Bohrung Ø3,0mm	Inlet Jet Screw, type "30"
011072	Verschlussstopfen, pneum. Kondensatventil	Plug PCV
011559	Reparatursatz pneum. Kondensatventil	Repair Kit PCV

C

**DETAILANSICHT / DETAILED VIEW**

**Pneum. Kondensat-Ablassventil / Pneumatic Condensate Valve**

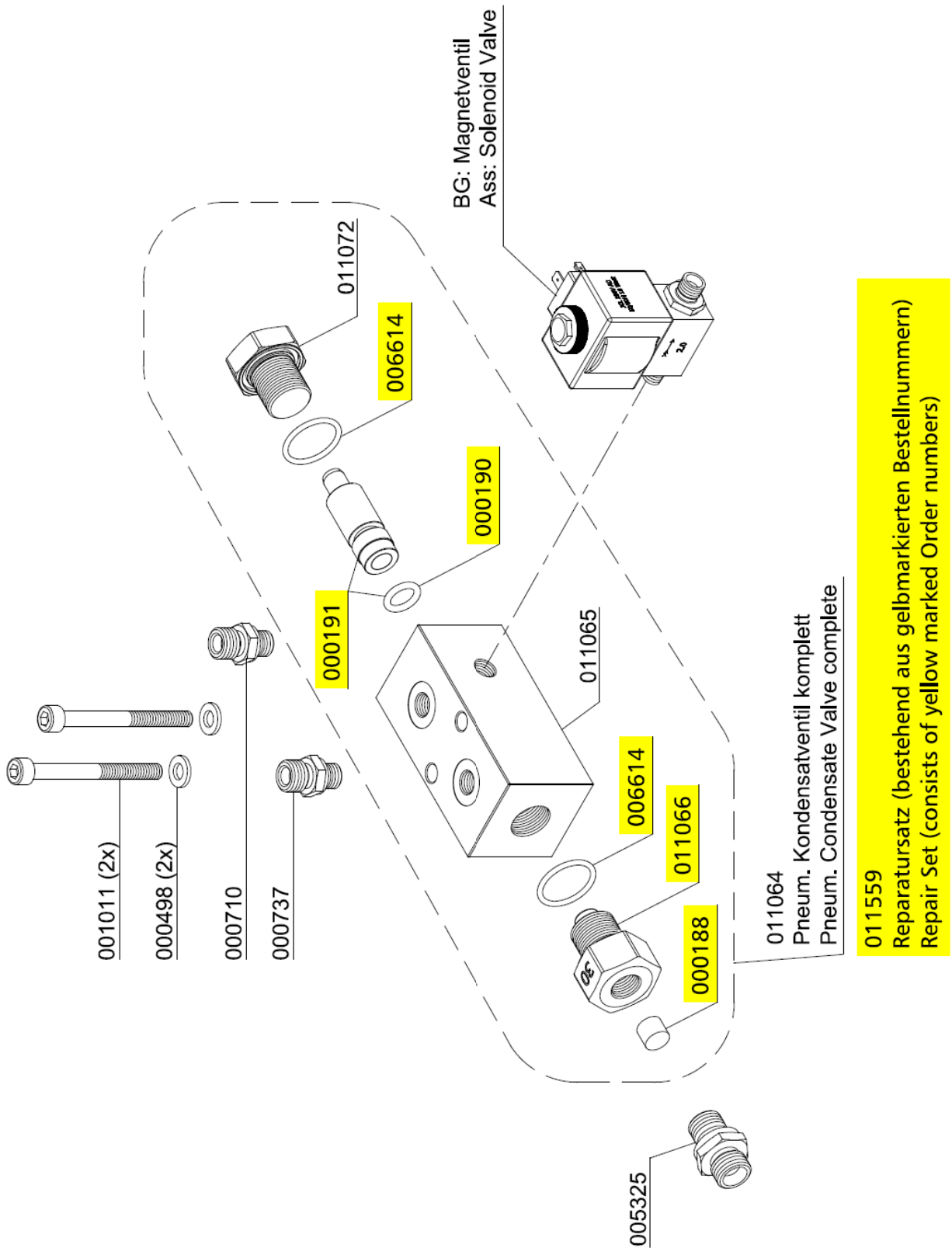



## ERSATZTEILLISTE / SPARE PART LIST

### Druckhalteventil / Pressure Maintaining Valve

Best.-Nr. / Order No.	Benennung	Description
000169	Druckhalterückschlagventil, schwarz	Pressure Maint. Valve black
000498	U-Scheibe DIN 125 A6	Washer DIN 125 A6
000506	Feder	Spring
000508	USIT Ring 13,7 x Ø20 x 1,5	Gasket Ring U-Sit 13,7 x Ø20 x 1,5
000511	Mutter, Druckhalterückschlagventil	Lock Nut PMV
000512	Schraube, Druckhalte-Rückschlagventil	Set Bolt PMV
000513	Druckstück für Druckhalteventil, Federadapter	Spring Adapter PMV, spring adapter
000514	Stift Druckhalte-/Rückschlagventil	Stud PMV
000515	Gehäuse, Druckhalte-Rückschlagventil	Main Body PMV
000516	Nutring, Druckhalterückschlagventil 5 x 10 x 5/2,5 90° Blau	Seal Ring PMV 5 x 10 x 5/2,5 90° blue
000517	Feder, Druckhalterückschlagventil	Coil Spring PMV
000518	Unterlegscheibe, Messing	Washer, Brass
000519	Dichtkappe, Druckhalte Rückschlagventil, schwarz	Plastic Seal Piston PMV, black
000520	Hohlschraube, DHRV	Inlet Jet PMV
006278	Zylinderschraube M6x50mm	Allen Bolt

Druckhalteventil / Pressure Maintaining Valve

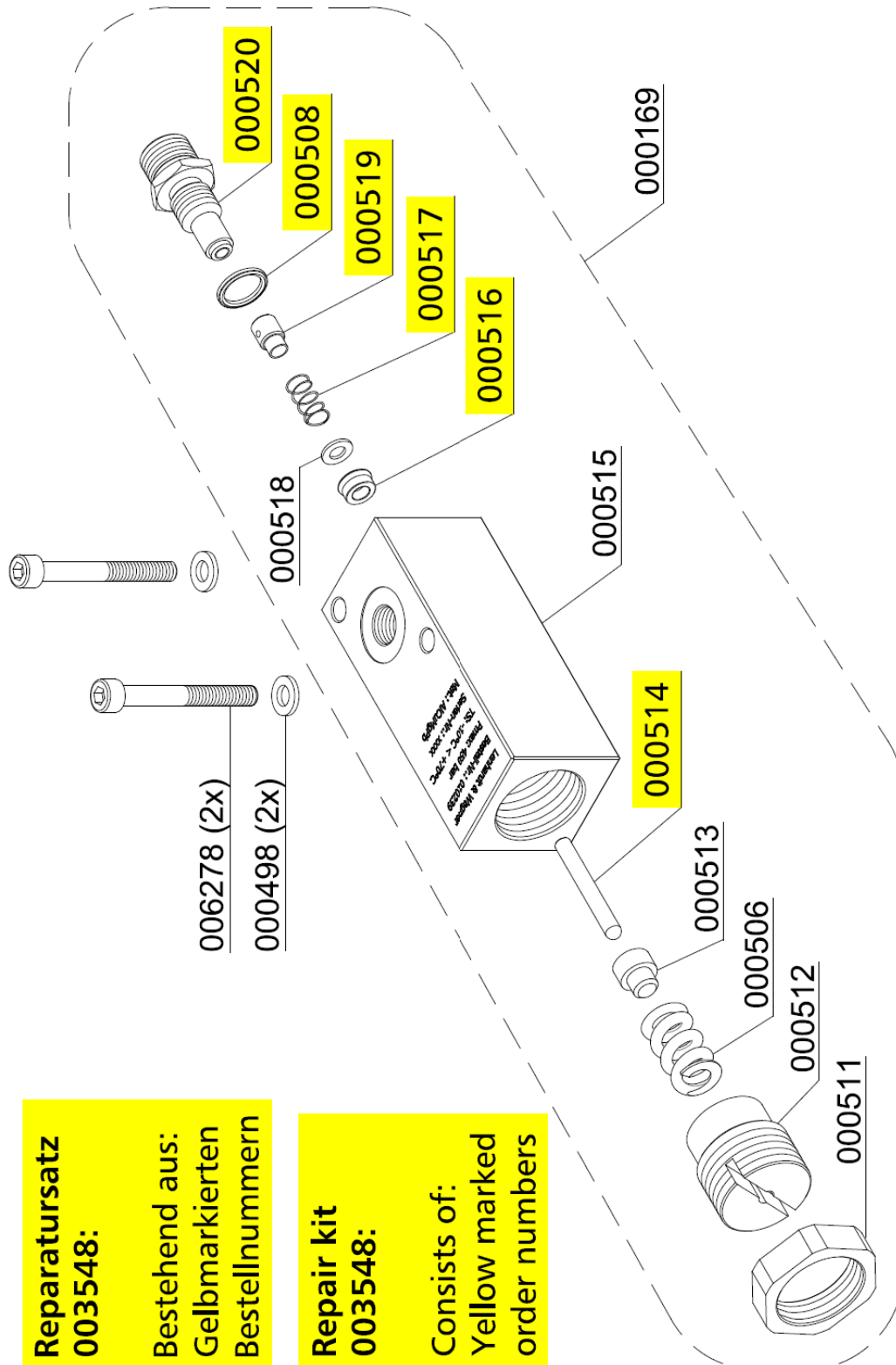

**Reparatursatz  
003548:**

Bestehend aus:  
Gelbmarkierten  
Bestellnummern

**Repair kit  
003548:**

Consists of:  
Yellow marked  
order numbers





**Druckschalter / Pressure Switch**

Best.-Nr. / Order No.	Benennung	Description
000203	Druckschalter, G1/4" IG, PV 50 - 350 bar	Pressure Switch 50-350 bar
000753	Verschraubung	Connection
009683	Verschraubung mit fester Mutter	Connection with fixed nut

C

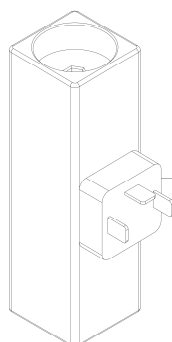

**000203**



**009683**



**000753**



## ERSATZTEILLISTE / SPARE PART LIST

### Magnetventile / Solenoid Valves

Best.-Nr. / Order No.	Benennung	Description
000799	Verschraubung	Connection with fixed nut
000892	Doppelnippel	Double Nipple
001546	Aludichtring für Magnetventile G1/4"	Alloy Seal Ring for G1/4" male
000616	Magnetventil 80 bar 2x1/4"	Solenoid NC 80 bar G1/4" 230V
002356	Schnellkupplung gerade, G1/4"-8mm	Quick rel. coupling, straight
005855	Winkeleinschraubverschraubung 8 mm, G1/4" - 8 mm, inkl. Mutter	Elbow Hose Connection 8 mm
006113	Magnetventil 0-55 bar	Solenoid 0-55 bar

C

**Magnetventile / Solenoid Valves**

für Pneum. Kondensat-Ablassventil  
for Pneum. Condensate Valve

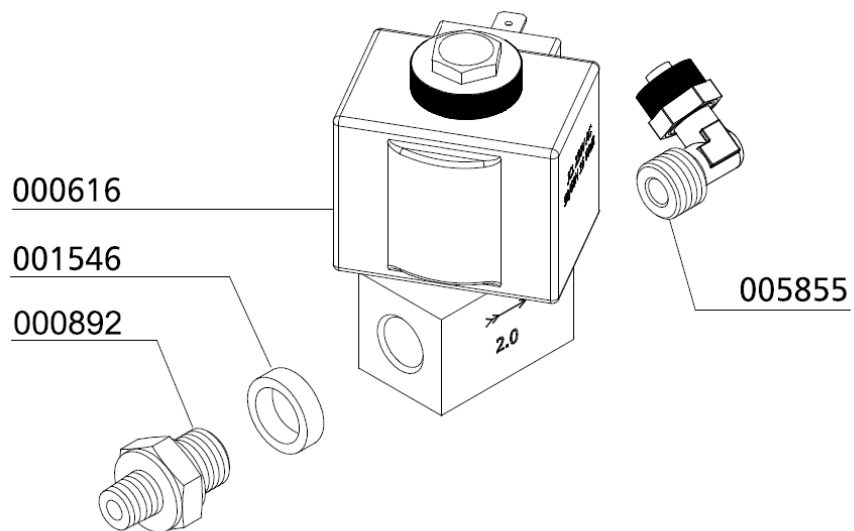

für Öl- Wasserabscheider 1. + 2. Stufe  
for Oil- Water Separator 1st + 2nd Stage

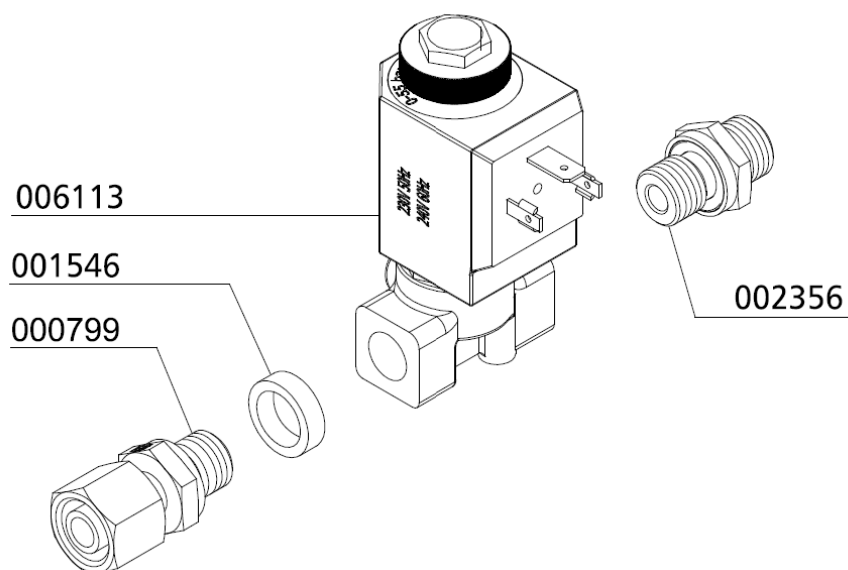



## ERSATZTEILLISTE / SPARE PART LIST

### Sicherheitsventil / Safety Valve

Best.-Nr. / Order No.	Benennung	Description
000233	Sockel für Sicherheitsventil mit TÜV, x G1/4" seitlich 180°	Base for Safety Valve TÜV type
000553	Sicherheitsventil 225bar mit TÜV	Safety Valve 225bar c/w TÜV
000554	Sicherheitsventil 250bar mit TÜV	Safety Valve 250bar c/w TÜV
000555	Sicherheitsventil 300bar mit TÜV	Safety Valve 300bar c/w TÜV
000556	Sicherheitsventil 330bar mit TÜV	Safety Valve 330bar c/w TÜV
000557	Sicherheitsventil 350bar mit TÜV	Safety Valve 350bar c/w TÜV
000761	Winkerverschraubung WE08LRA3CX	Elbow Connection WE08LRA3CX
000838	Verschlussstopfen VSTIR1/4EDCF	Plug VSTIR1/4EDCF
001044	Zylinderschraube, M8x40mm DIN912	Allen Bolt
001058	Zylinderschraube, M8x70mm DIN912	Allen Bolt
001158	Mutter, M8 DIN934	Nut
001181	U-Scheibe, A8 DIN125	Washer
001244	O-Ring, Flansch Sicherheitsventil	O-Ring, Flange Safety Valve
001814	Sicherheitsventil 225bar mit CE	Safety Valve 225bar with CE
001815	Sicherheitsventil 250bar mit CE	Safety Valve 250bar with CE
001816	Sicherheitsventil 330bar mit CE	Safety Valve 330bar with CE
001817	Sicherheitsventil 350bar mit CE	Safety Valve 350bar with CE

C

## DETAILANSICHT / DETAILED VIEW

### Sicherheitsventil / Safety Valve

Druck	SV-Ventil mit CE-Prüfung	SV-Ventil mit TÜV-Prüfung
225 bar	001814	000553
250 bar	001815	000554
285/300 bar	-----	000555
330 bar	001816	000556
350 bar	001817	000557

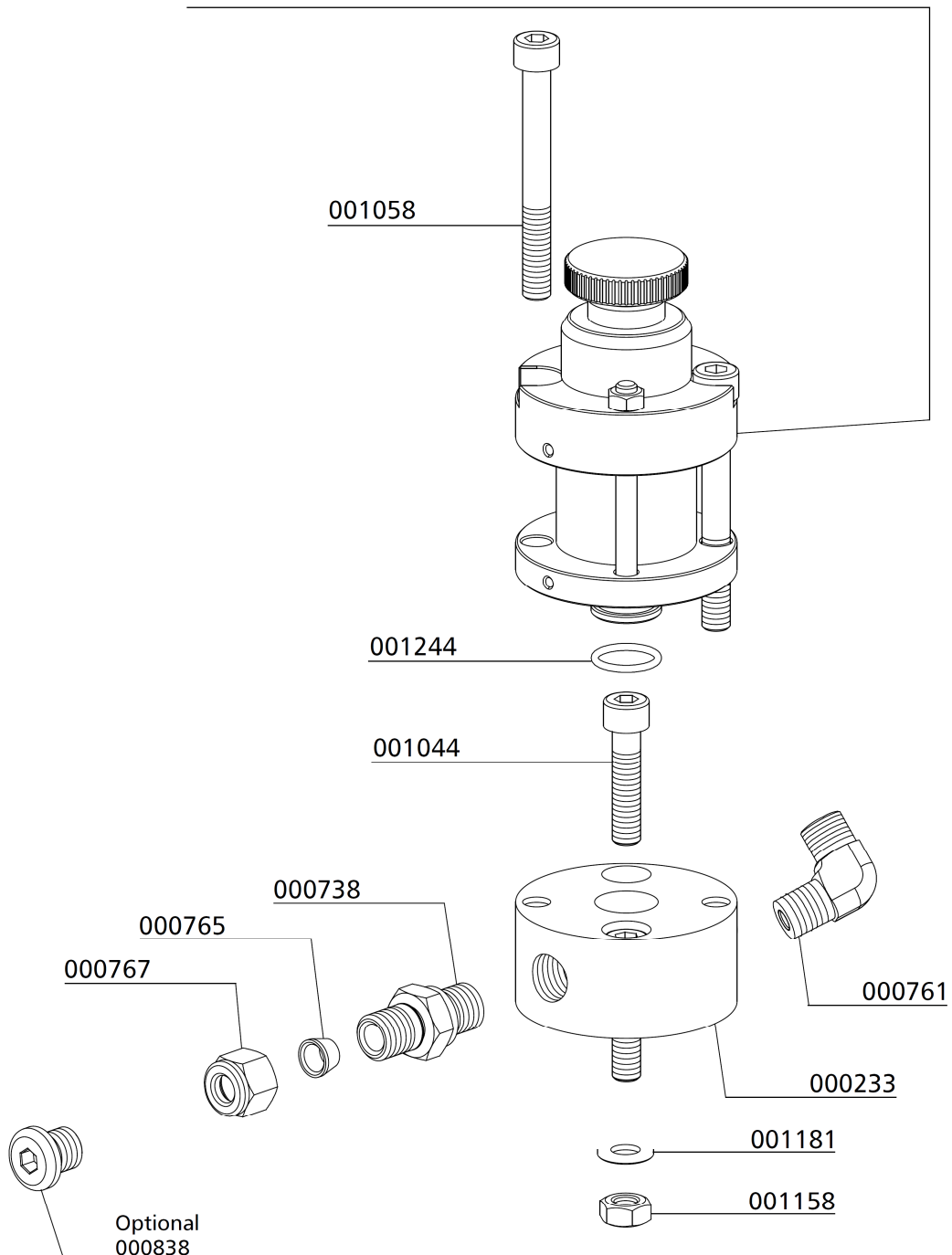

C

**Ansaugfilter / Intake Filter**

Best.-Nr. / Order No.	Benennung	Description
000170	Ansaugfilterpatrone	Air Intake Filter Cartridge
001772	Flügelmutter, PVC-schwarz	Winged Nut, PVC black
001782	O-Ring, Ansaugfiltergehäuse	O-Ring, Intake Filter Housing
009652	Gehäuse für Ansaugfilter	Intake Filter Housing
009653	Deckel für Ansaugfilter	Cover Intake filter housing
009658	O-Ring	O-Ring

C

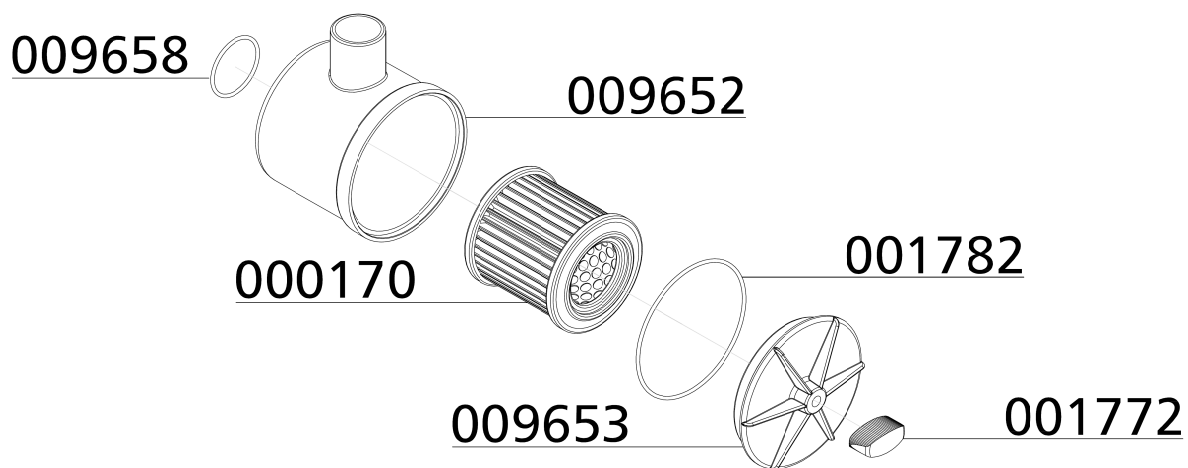



## ERSATZTEILLISTE / SPARE PART LIST

### Ölpumpe / Oil Pump

Best.-Nr. / Order No.	Benennung	Description
000200	Ölpumpenhalteflansch	Adapter Flange Oil Pump
000204	Ölpumpe, kompl.	Oil Pump compl.
000208	Ölpumpenantriebsflansch	Drive Flange Oil Pump
000250	CU-Ring	Copper Washer
000355	Öldruckleitung 6mm, kompl. m. Muttern	Oil Pressure Pipe c/w nuts
000356	Öldruckleitung 6mm, kompl. m. Muttern	Oil Pressure Pipe c/w nuts
000710	Verschraubung, GE06L	Connection w/o nut& olive seal
000716	Verschraubung, TE G1/8" / 6L	Connection w/o nut& olive seal
000732	Überwurfmutter	Union Nut 06L
000733	Schneidring 6 mm	Olive Seal SR 06 (Ø 6mm)
000739	Verschraubung, TE G1/8" / 6L	Connection
000759	Verschraubung, WE 08 LL R 1/8"	Elbow connection c/w nut&olive
000765	Schneidring 8 mm	Olive Seal 8 mm
000766	Überwurfmutter 08 L	Nut
000952	6-kant Schraube, M6x20mm, DIN933	Hexagon Bolt
000958	Gewindestift, Madenschraube	Hexagon Socket Screw
001014	Gewindestift mit Zapfen, M6X14mm DIN915	Hexagon Socket Screw
002340	O-Ring Ölpumpenflansch	O-Ring, oil pump flange
005487	Rohrleitung 8mm	Pipe s/s

C

**DETAILANSICHT / DETAILED VIEW**

**Ölpumpe / Oil Pump**

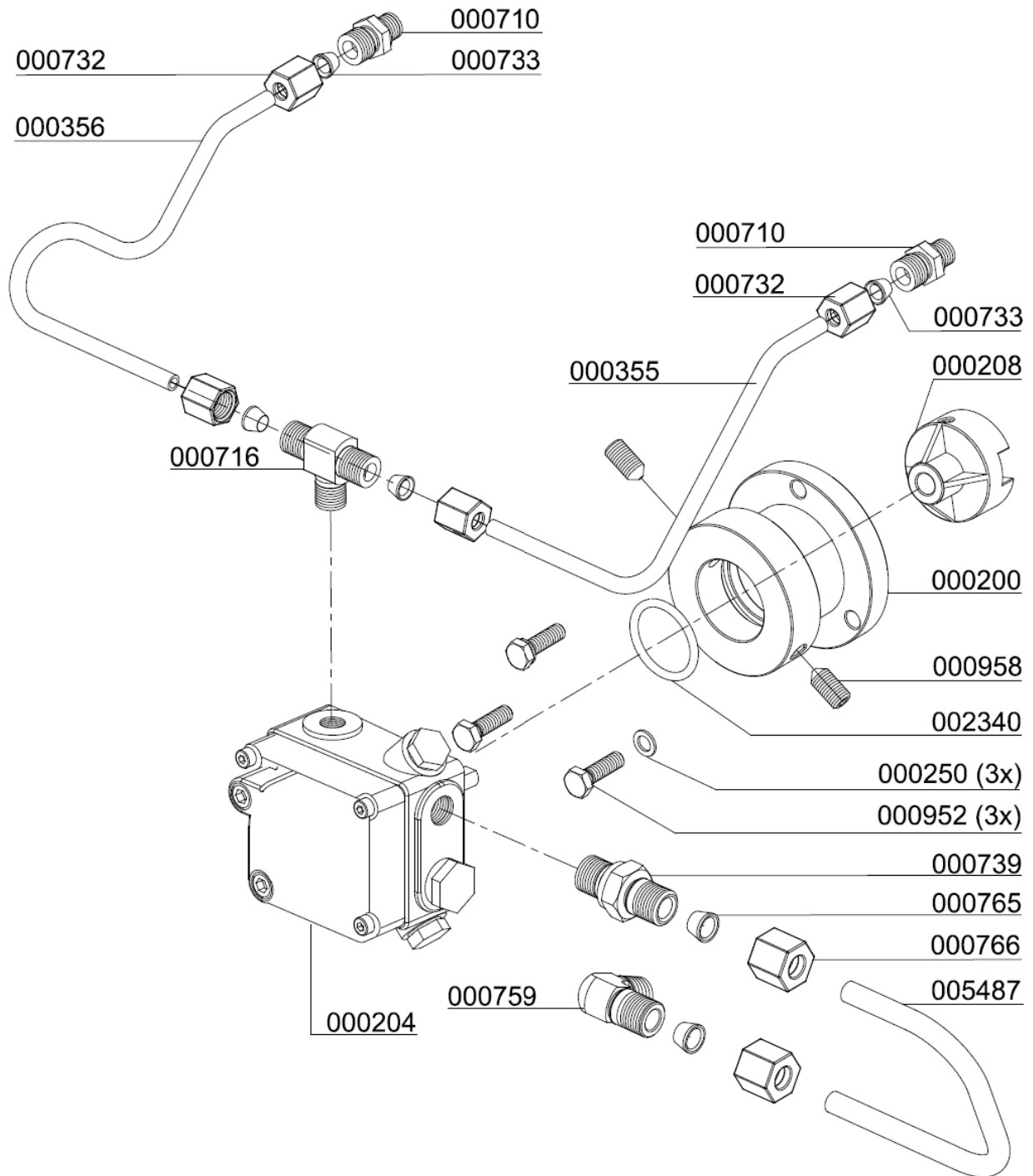

C



## ERSATZTEILLISTE / SPARE PART LIST

### Ölablassschlauch - Oil Drain Hose

Best.-Nr. / Order No.	Benennung	Description
000817	Verschraubung	Connection
001548	Ölablassventil (Kugelhahn)	Oil Drain Valve - ball valve
002153	Ölablassschlauch inkl. Kugelhahn	Oil drain hose c/w ball valve
006417	Ölablassschlauch	Oil drain hose
008655	Linsenflanschschraube mit Innensechskant	Flange Button Head Screw
009772	Halter Öl-Ablassschlauch	Holder Oil drain hose

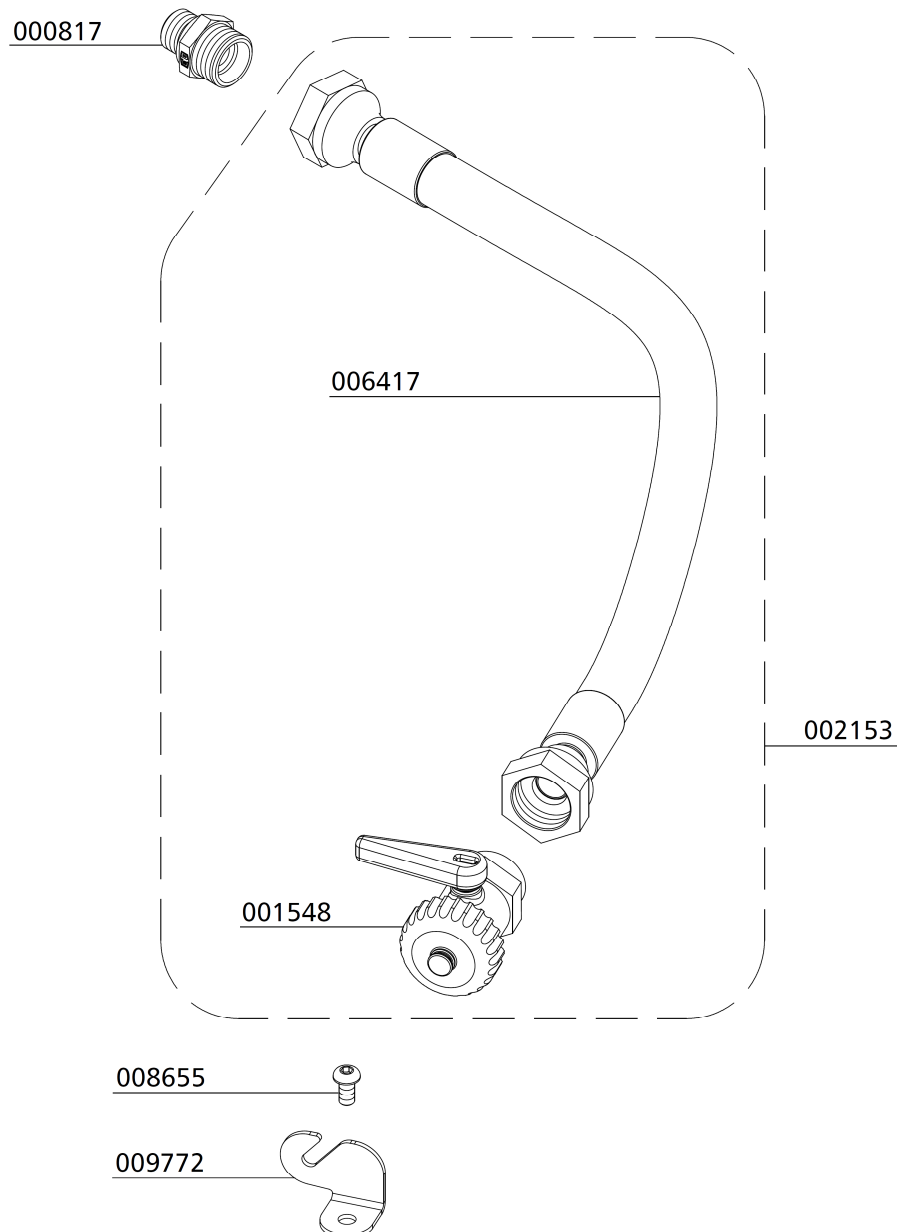



## ERSATZTEILLISTE / SPARE PART LIST

### Motor / Engine

Best.-Nr. / Order No.	Benennung	Description
001129	Schlossschraube	Carriage Bolt
001165	Mutter	Nut M12
001191	U-Scheibe A12	Washer A12
001192	Federring A12	Spring Washer A12
001211	Passfeder	Woodruff Key
008519	Spannbuchse für Riemenscheibe	Pulley Clamp Bush Ø38 mm
008531	Keilriemen, XPA 1800	V-Belt
010697	Riemenscheibe, SPA125-2, 1610	Pully SPA 125x2-1610
011870	Antriebsmotor 15 kW,400V	Drive Motor
011871	Antriebsmotor 15 kW, 230V	Drive Motor

C

ERSATZTEILLISTE / SPARE PART LIST

Motor / Engine

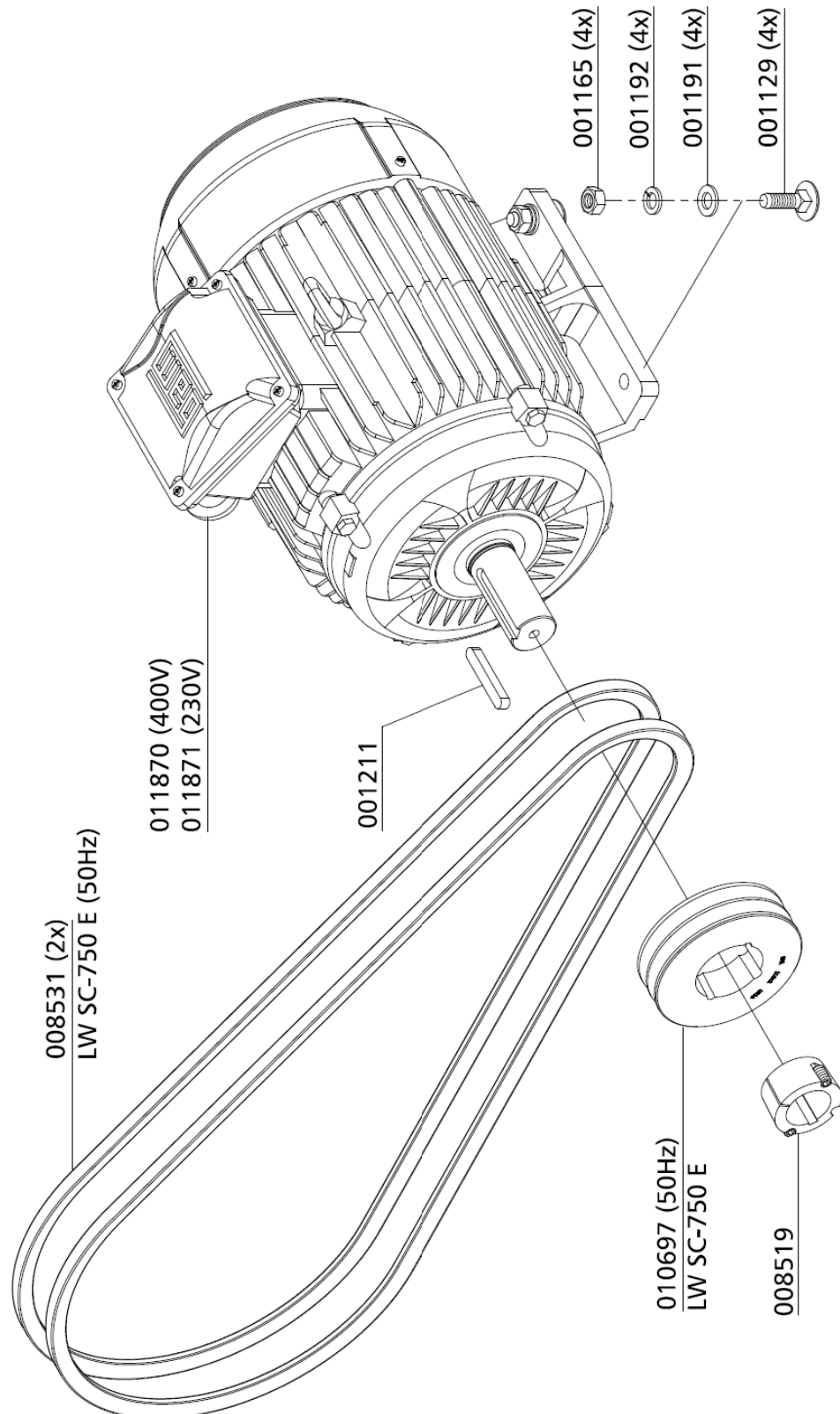

C



## ERSATZTEILLISTE / SPARE PART LIST

### Lüfterrad / Cooling Fan

Best.-Nr. / Order No.	Benennung	Description
000317	Schwungscheibe	Flywheel
000318	Zentrierring, Lüfterblätter	Fixing Ring Fan Blades
000498	U-Scheibe A6	Washer A6
001030	Zylinderschraube, M6x16mm DIN912 8.8 ZN	Allen Bolt, M6x16mm DIN912 8.8 ZN
001133	6-kant Schraube	Hexagon Bolt M12x30
002335	Ventilatorflügelblatt, schwarz	Fan Blade, black, new version
005122	U-Scheibe Kurbelwelle	Washer, crank shaft
010168	Zahnscheibe A12	Lock Washer A12

C

**DETAILANSICHT / DETAILED VIEW**

**Lüfterrad / Cooling Fan**

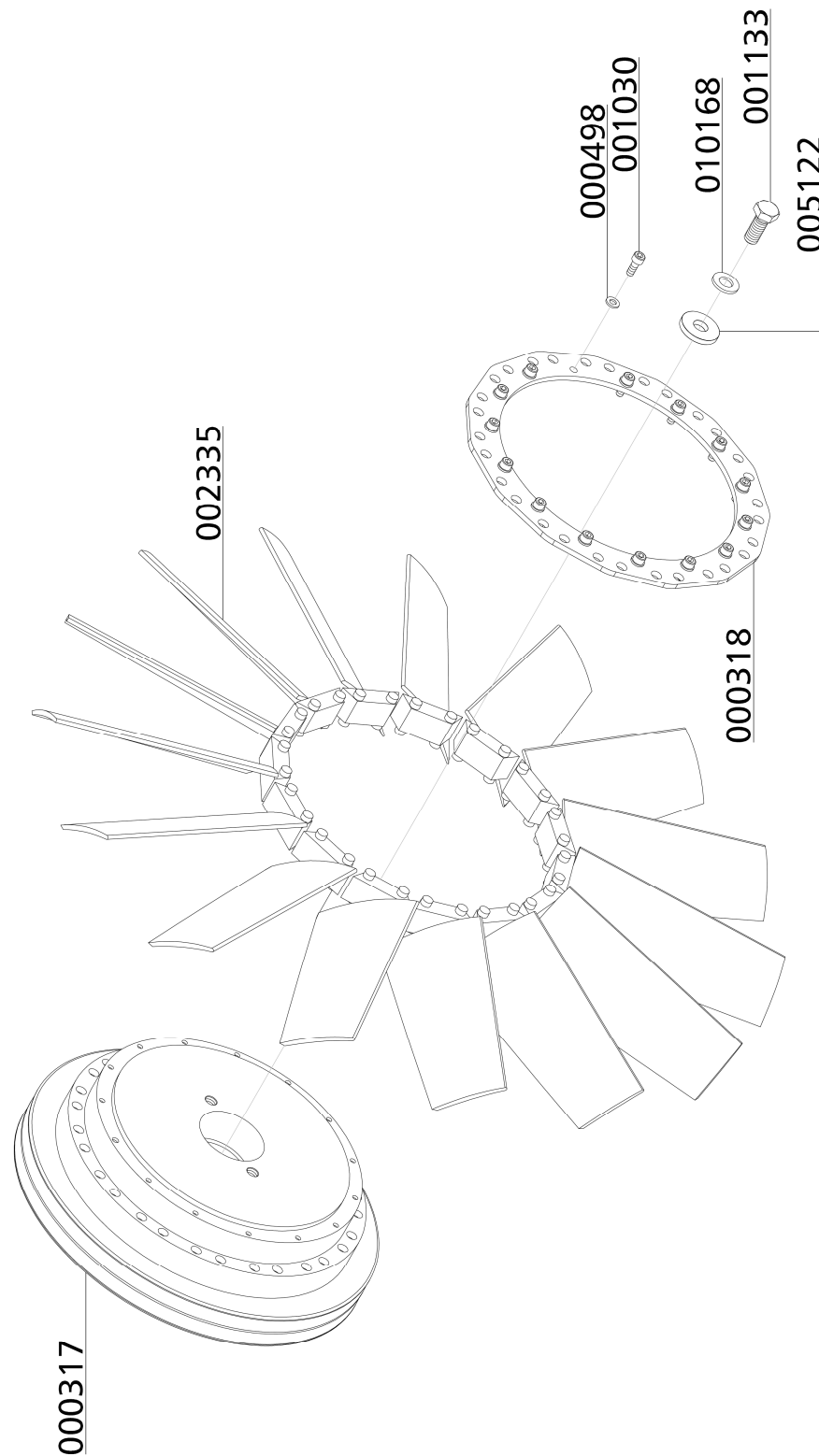



# ATTACHMENT

E

**Lenhardt & Wagner GmbH**

**An der Tuchbleiche 39  
D-68623 Lampertheim – Hüttenfeld**

www.lw-compressors.com



## Operating Instruction

### Safety valve

Typ:

**SiV2 BKZ TÜV.SV.19-1140.5.G.V.P CE 0091 AlMgSi1 F31 1100\* Lenhardt & Wagner**

<b>Set pressure:</b>	see mark (hand wheel on top of valve)
<b>Maximum outflow:</b>	Set pressure 100-159 bar: 750 l / min Set pressure 160-350 bar: 1.100 l / min
<b>Suitable media:</b>	Media-resistant, non-corrosive gases

The safety valve is used for protection of pressurized components, eg pipelines, pressure vessels, or the compressor itself.

The hand wheel on the top of the safety valve is marked with the adjusted set pressure.



- 1) *Identification of set pressure*
- 2) *Seal*
- 3) *Fixing screws<sup>1</sup>*
- 4) *Venting screw (hand wheel)*
- 5) *Identification serial number*
- 6) *Socket for safety valve*

Safety valve with socket

<sup>1</sup> The fixing screws M8 must be strength class 8.8 and meet the requirements of Merkblatt AD 2000 leaflet W7. Shaft length 70mm.

In order to prevent manipulation of the set pressure, all safety valves are factory fitted with a seal.

A safety valve on which the seal has been removed, must be returned to the manufacturer for repair / adjustment before further use.

In addition, the safety valve has a venting device (hand wheel).

When rotated clockwise, the safety valve and the filter housing of the final stage are completely vented.

During normal operation, the screw is unscrewed to the upper stop anticlockwise; an integrated safety ring prevents the screw from being removed.

---

If a safety valve blows off, the system must be switched off immediately and the cause of the error, investigated.

There are two possible reasons:

1. The safety valve is defective and blows off before the set pressure.

In this case the safety valve should be submitted immediately to the manufacturer for repair or replaced with a new one.

2. The safety valve opens properly, the problem is on the system.

A constant blowing of the safety valve is not permitted, the sealing seat of the valve can be damaged. The error on the system must be detected and repaired before further filling operations.

The safety valve may only be used if it is ensured that the maximum flowrate of the system does not exceed the blow-off rate of the safety valve.

The safety valve may only be used with the approved media.

Repair work on compressors must only be performed by trained personnel.

### **Dismantling of the safety valve**

Ensure that on the safety valve is no pressure.

Loosen and remove the two M8 fixing bolts with a 6 mm Allen key.

The safety valve can now be removed by turning and simultaneously pulling out of the socket.

### **Mounting**

1. Clean the safety valve socket.

2. Oil the insert pin of the safety valve including the O-ring with 1 to 2 drops of oil.

3. Press the safety valve pin complete into the socket.

4. Fasten the safety valve with the two 8 mm allen screws into the socket

(Tightening torque: 10 Nm)

5. Screw the venting screw (hand wheel) anticlockwise to its upper limit.

6. Start the System (Compressor), check installation for leaks and proper function.



**Manufacturer:** Lenhardt & Wagner GmbH  
An der Tuchbleiche 39  
D-68623 Lampertheim – Hüttenfeld

**Contact:** E-Mail: [service@lw-compressors.com](mailto:service@lw-compressors.com)  
Web: [www.lw-compressors.com](http://www.lw-compressors.com)  
Tel.: +49 (0) 6256 – 85880 0  
Fax: +49 (0) 6256 – 85880 14

---

**Note:**

*Only use safety valves which are in a technically perfect condition, for its intended purpose, safety and danger awareness, in compliance with the operating instructions!*  
*Faults which could affect safety must be rectified immediately!*

Notes:

- The safety valve must be installed directly on the protected pressure vessel and / or the plant.
  - The safety valve must be installed in an upright position.
  - The flow area of the port must be greater than the valve opening.
  - Protect valve against splashes
- 

Maintenance:

- In accordance with current Pressure Equipment Directives, the safety valve must be periodically checked for operation and reliability.
- Refill annually lubricating oil:  
Oil filling position:  
Hole on the spacer (see arrow, Figure 1)
- Oil quantity: 5-10 drops



Figure 1: Position for oil refill

*To be used lubricating oil for the safety valve: L&W Article N°. 008500*

---



INFORMATION ON THE  
SERVICE LIFE OF  
L&W HIGH PRESSURE HOSES





## CONTENTS

---

Testing hose lines	
Testing hose lines .....	3
Testing after assembly and before commissioning .....	3
Recurring test .....	4
Procedure for hose lines found to be "defective" .....	4
Test intervals .....	4
Persons qualified to test hose lines .....	5
 Maintenance	
Replacing hose lines .....	6
Immediate replacement of hose lines .....	6
 Service life	
Service life of L&W high pressure hoses .....	7
 Storage	
Storing hose lines .....	8
 Annex	
Scope of testing, test criteria .....	10 - 11



## TESTING HOSE LINES

---

### **Testing hose lines**

An essential factor in ensuring operational safety when handling L&W compressors is the proper testing of the hose lines used.

Tests are necessary:

- After assembly and before commissioning the hose line.
- After accidents, changes (modifications) to the compressor system, longer periods of non-use and damage due to, for example, collisions or natural phenomena (extraordinary test).
- After carrying out repair work on the compressor system that could compromise safety.
- Recurrently at fixed, regular intervals.

The proprietor must determine the type, scope and deadlines for the tests according to his or her individual operating conditions and on the basis of a risk assessment. **The specifications and recommendations of the manufacturer must be observed.** The specifications made regarding type, scope and deadlines (as well as the replacement intervals) must be documented in writing as occupational health and safety measures.

The results of the tests must also be recorded, e.g. together with the test report of the machine, and kept at least until the next test.

The above-mentioned tests may only be carried out by persons who are qualified to do so and who are authorized by the company (employer).

### **Testing after assembly and before commissioning**

In the test after assembly and before commissioning, factors relating to assembly or factors that can only be evaluated on the fully assembled machine must be assessed.

The assembled hose lines must also be assessed.

Some test points can already be assessed during a visual inspection when the machine is switched off.

An overview of the recommended scope of testing for a visual inspection of hose lines is given in the appendix.

Further test points included in the test of hose lines before commissioning, require a functional test with the machine running.

A recommendation for the scope of testing is given in the appendix.



## TESTING HOSE LINES

---

### **Recurring test**

Since hose lines are subject to influences that cause damage during operation and can lead to dangerous situations, they must be tested recurrently at fixed intervals. The aim of recurring tests is to detect and repair damage in good time.

The objective is to ensure that the system remains in a safe condition.

### **Procedure for hose lines found to be "defective"**

If defects are found during the testing of the hose line that impair the safe condition of the work equipment, these must be rectified immediately. If this is not possible, suitable measures must be taken to ensure that the machine cannot be used further before it is repaired. Defective hose lines must be replaced before the machine can be used further.

It is not permitted to repair or reassemble damaged hose lines with old, previously used parts!

If several hose lines are replaced at the same time, precautions must be taken to prevent mix-ups of the connections or the installation points.

### **Test intervals**

Deadlines for the recurring tests of the hose lines should already be set before commissioning.

Otherwise, there is a risk that work equipment will continue to be used or operated for too long without being tested.

The intervals between the recurring tests must be selected in such a way that deviations from the safe operating condition of work equipment can be detected and eliminated in good time.

The intervals for recurring tests specified here are guidelines and based on experience. Shorter test intervals may have to be specified on the basis of the risk assessment; special operating conditions; or according to the manufacturer's specific instructions in the machine operating manual. Longer test intervals may also be specified, provided that this is justifiable and tenable from a safety point of view. The determination of the test intervals should be documented.

<b>Type of test</b>	<b>Recommended test intervals</b>
Visual inspection	Before commissioning the system
Functional test	Annually with previous visual inspection



### **Persons qualified to test hose lines**

A qualified person is a person who, through his or her professional training, professional experience and recent professional activity, has the necessary specialist knowledge required for testing work equipment - in this case for testing hose lines.

These requirements are defined in the Technical Rules for Industrial Safety TRBS 1203

"Qualified persons - general requirements" fulfilled if:

- the qualified person has completed a professional training that enables his or her professional knowledge to be determined in a comprehensible manner, i.e. based on professional qualifications or comparable evidence. For the testing of hose lines, the person concerned must have completed a technical professional training or another technical qualification sufficient for the intended testing tasks. The object is to guarantee that the tests will be carried out properly.
- proof of practical use at work of the equipment to be tested as well as the associated professional experience is provided. The qualified person must be sufficiently familiar with the conditions that demand the performance of tests, such as the result of the risk assessment or observations during the working day.
- there is proof of recent professional activity in the area of the upcoming tests and appropriate further training. The qualified person must also have gained experience with regard to the tests to be performed or comparable tests. He or she must also have knowledge of the state of the art with regard to the work equipment or components to be tested as well as the hazards to be considered. This also includes knowledge of the relevant technical regulations and the updating of this knowledge, e.g. through participation in training courses/instruction.

The qualified person is not subject to any technical instruction during the course of his or her testing activity and must not be disadvantaged because of this.

Experts who have carried out tests on the hose lines up to now and who meet the three criteria mentioned above and who have familiarized themselves with the contents of the German Ordinance on Industrial Safety and Health and the changes associated with it are also considered qualified persons to whom the tests can continue to be assigned.

See also:

- ⇒ § 2 para. 7 of the German Ordinance on Industrial Safety and Health,
- ⇒ Technical Rules for Operational Safety TRBS 1203.



### **Replacing hose lines**

As a general rule, even when stored properly and subjected to permissible stress during use, all hose lines are subject to natural aging, which changes the material and composite properties and reduces the performance of the hose lines.

This limits the service life of a hose line and the operator must ensure that hose lines are replaced at appropriate intervals.

### **Immediate replacement of hose lines**

Hose lines must be replaced immediately in the event of the following defects:

- External visible damage to the hose line or fittings.
- Internal damage to the tube or the reinforcement.
- Leakage from the hose line or the fittings.
- Deformation of the hose line or the fittings.



### **Service life of L&W high pressure hoses**

When determining the service life or the replacement interval of the individual hose lines, the concrete specifications and recommendations of the hose line or machine manufacturer must be observed. Furthermore, empirical values resulting from previous tests done under the prevailing operating conditions on site are also relevant.

Guideline values for recommended replacement intervals of hose lines which have proven themselves in practice are summarized below.

<b>Hose line requirements</b>	<b>Recommended replacement intervals</b>
Standard requirements	6 years (Service life including a maximum of 2 years storage time)
Increased requirements, e.g. due to - increased operating time, e.g. multi-shift operation, or short machine or pressure pulse cycle times - strong external and internal influences (due to the medium), which greatly reduce the service life of the hose line	2 years (service life)

The guideline given above for a replacement interval of six years for hose lines meeting normal requirements includes a maximum storage period of two years. The guideline value of two years for hose lines meeting increased requirements represents the maximum permissible service life.

A prolongation of the guideline values given above for replacement intervals is possible if

- appropriate test values and empirical values are available from the operator of the machine which permit safe continued use beyond the recommended maximum service period,
- a hazard or risk assessment, documented in writing, has been carried out by the operator, which also takes into account protective measures in the event of failure of hose lines, and
- tests for safe working conditions are carried out by qualified persons at appropriately set, if necessary reduced, intervals.

It must be ensured that the prolongation of the replacement intervals does not result in a dangerous situation that could injure employees or other persons.

If hose lines fail during operation or if damage or defects are frequently detected during the recurring tests, then, in addition to investigating the causes, the test and replacement intervals must be shortened.





## STORAGE

---

### **Storing hose lines**

When storing hose lines, storage conditions must be aimed at minimizing the natural aging that occurs over time and the associated change in material and composite properties.

For this purpose, the following information must be provided:

- Store in a cool, dry and low-dust place.  
Low-dust storage can be achieved, for example, by wrapping the hoses in plastic film.
- Avoid direct sun or UV radiation.
- Shield from nearby heat sources.
- Avoid storage temperatures below -10 °C for elastomers.
- Do not use ozone-generating light fittings or electrical devices that may produce sparks in the immediate vicinity.  
(Ozone-generating light fittings are, for example, fluorescent light sources, mercury vapor lamps).

The most favorable storage conditions are temperatures between +15 °C and +25 °C, as well as a relative humidity below 65 %.

During storage, hose lines must not come into contact with substances that could cause damage, e.g. acids, alkalis, solvents. Penetration of ozone or other harmful air constituents can be prevented by sealing the ends or by wrapping the hoses in plastic film. They must be stored flat and free of tension.

The storage period for hose lines should not exceed two years.



## ANNEX



## ANNEX SCOPE OF TESTING; TEST CRITERIA

---

### **Recommended scope of testing "visual inspection" (before initial commissioning or recommissioning)**

- Is all user information required for safe operation of the system available (e.g. flow chart, operating instructions)?
- Do the hose lines comply with the flow chart or parts list?
- Are there protective measures in place, such as pressure relief valves, for cases of unusually high pressure pulses or pressure amplifications?
- Are the hose lines marked with the name or abbreviation of the manufacturer, maximum permissible operating pressure, nominal diameter, quarter/year of manufacture?
- Are the hose lines installed in such a way that, in accordance with DIN 20 066
  - the natural position does not hinder movement?
  - turning or twisting of the hose is prevented, likewise tensile load caused by a line that is too short and a bending radii that is too small?
  - the hose is routed via a kink protector (if necessary on the connecting element)?
  - sufficient clearance prevents external mechanical influences or abrasion on the edges?
  - hose bridges prevent damage being caused by driving over the hose line?
  - hose guides (such as hose saddles and sufficiently wide hose brackets) protect loosely laid hose lines and
  - a heat shield protects against high temperature exposure?
- Are suitable protective measures, such as fixtures, safety gear or shielding provided for hose lines that, in the event of failure, pose a risk of whipping?  
A risk is to be assumed if persons are generally present in the immediate vicinity of the hose lines, for example.
- Do the hose lines of newly commissioned or re-commissioned machines already show signs of damage?
- Are the installed hose lines still within the storage/use period recommended by the relevant manufacturer?
- Are the hose lines free of paint?
- Are the hose lines free of chafe marks?
- Does the operating manual contain information on test intervals? If so, what?

#### Note:

The installed hose lines should not be made from used hoses or used press fittings that have already been in use as part of a hose assembly!



## ANNEX SCOPE OF TESTING; TEST CRITERIA

---

### **Recommended scope of testing "Functional test" (before initial or recommissioning)**

Note:

Visual inspection must be carried out before the functional test

- All parts of the system must be tested at least at the maximum working pressure that could be achieved taking into account all intended applications:
  - Are the hose lines and connecting elements free of leakage?
  - Have all hose lines withstood the pressure?

Note:

The installed hose lines should not be made from used hoses or used press fittings which have already been in use as part of a hose assembly!