



CHAPTER OVERVIEW

Operating Instructions

A

.....

B

Spare Parts Lists

C

Options (if equipped)

D

Attachment

E

Manufacturer in terms of 2014/68/EU

The full name and address of the manufacturer is:

Lenhardt & Wagner GmbH

An der Tuchbleiche 39

68623 Hüttenfeld / Germany

Phone: +49 (0) 62 56 - 85 88 0 - 0

Fax: +49 (0) 62 56 - 85 88 0 - 14

E-Mail: service@lw-compressors.com

Internet: www.lw-compressors.com





SERVICE INFORMATION / WARRANTY

Compressor information

Type designation

Serial number

Date of construction

Purchase information

Purchase date

First commissioned on

Warranty period

Dealer's stamp

Warranty

L&W will uphold warranty claims made during a period of 12 months from the invoice date.

If the compressor was purchased from an official L&W dealer, the date on the dealer's invoice is valid. Warranty claims can only be made on presentation of the original invoice.

Should verifiably defective parts have been delivered, we will decide to either replace the parts or repair them. The resulting transport and assembly costs will be invoiced.

No reduction of the purchase price or changes to the contract can be made. The parts for which a claim is being made should be kept safe by the purchaser and, when requested, sent to us at their cost. Replaced parts become the property of L&W. If maintenance work is carried out without our knowledge or permission by the purchaser or a third party, we are absolved from any liability for warranty claims. As a matter of principle, warranty claims can only be made by the initial purchaser.

Operating Instructions

Breathing Air Compressor

LW 150 E MC / LW 200 E MC / LW 250 E MC





TABLE OF CONTENTS

General Information and Technical Data

General Information / Description of Warning Symbols	4
Scope of Delivery	5
Technical Data	6
Unit Assembly	7
Phase selector switch	8
Flow chart	9

Safety Precautions

Intended Use / Operators	11
Safety instructions on the unit	12
General Safety Precautions	13
Unit customised safety notices	14
Maintenance instructions	15
Transportation instructions / Safety regulations	16

Installation

Installation in closed rooms	18
Dimensions	19
Minimum distances	20
Ventilation	21
Electrical Installation	22 - 23

Operation

Important operation instructions	25
First commissioning	26 - 27
Daily commissioning	28
Filling procedure	29
Switch off the compressor	30

Remedying faults	32 - 35
-------------------------------	---------

A



TABLE OF CONTENTS

Maintenance and Service

Service, Repair and Maintenance	37
Maintenance Lists / Maintenance Intervals	38 - 40
Service Kits	41
Check V-belt tension / Tension V-belt / Settings	42
Compressor lubrication / Check oil level	43
Oil change	44
Manual condensation dump system	45
Oil / water separators 2nd stage - maintenance	46
Filter housing / Filter cartridge	47
Filter cartridge change	48
Filter housing - maintenance	49
Inlet Filter	50
Check or change filter inlet	51
Valve heads and valves / Pistons and Cylinders / Cooling	52
Replace inlet and outlet valve 1st stage	53 - 54
Replace inlet and outlet valves 2nd / 3rd stage	55
Safety valves	56
Pressure maintaining / non return valve	57
Adjust pressure maintaining valve	58
O-rings - filling valve and filling hose	59
Pressure gas vessel test	60
Maintenance records	62 - 66

Storage

Conservation / storage of the compressor	67
De-conservation, commissioning	68
Transportation instructions / Disposal / Electric and electronic components	69

A

GENERAL INFORMATION

General Information

We strongly recommend reading this manual thoroughly prior to operation and follow all the safety precautions precisely. Damage resulting from any deviation from these instructions is excluded from warranty and liability for this product. Carry out other commissioning steps only if you have fully understood the following contents.

Before commissioning and using the unit, carry out all the essential preliminary work and measures concerning legal regulations and safety. These are described on the following pages of this operation manual.

A

Description of marks and warning signs

The following warning signs are used in this document to identify the corresponding warning notes which require particular attention by the user. The warning signs are defined as follows:



Caution

Indicates an imminently hazardous situation which, if not avoided, could result in serious injury, physical injury or death.



Warning

Indicates a potentially hazardous situation which, if not avoided, could result in physical injury or damage to the product or environment.



Note

Indicates additional information on how to use the unit.



DESCRIPTION

Scope of Delivery LW 150 E MC / 200 E MC / 250 E MC

Compressors are provided in different equipped versions.

A

Versions

Filling pressure versions:

- PN 225 bar
- PN 330 bar
- PN 225 / 330 bar

Specifications

- Electro motor (Standard: 400V, 3 phase, 50Hz) c/w cable and plug
- Start/Stop switch c/w phase selector function
- Manual condensate drain
- 1 x Filling hose c/w filling valve and pressure gauge
- Pressure maintaining and non return valve
- All pistons c/w steel piston rings
- Oil- / Water separators after 2nd and 3rd stage
- Safety valves after each stage
- 3 x concentric suction/pressure valves
- Filling pressure to your choice (200 or 300 bar)
- Connections to your choice (DIN 200 bar or 300 bar, CGA 200 bar or 300 bar and INT)
- Breathing air purification in accordance to EN 12021

Options

- Automatic condensate drain
- Automatic stop at final pressure
- Additional filling hose c/w filling valve
- Auto start system
- Phase monitoring c/w shut down at wrong direction of rotation
- Switch over device 200/300 bar
- Hour counter
- Intermediate pressure gauges
- Cylinder head temperature monitoring with auto shut down
- Puracon filter monitoring (Auto shut down also available)
- Remote control box
- Additional high pressure outlet
- Power cable and plug
- Special voltages / frequencies on request



DESCRIPTION

Technical Data

Technical Data	LW 150 E MC	LW 200 E MC	LW 250 E MC
Capacity [l/min]:	150	200	250
Max. Operating Pressure [bar]:	350	350	350
RPM [min ⁻¹]:	1425	1425	1825
Number of Pressure Stages:	3	3	3
Cylinder Bore 1st Stage [mm]:	Ø 72	Ø 75.5	Ø 80
Cylinder Bore 2nd Stage [mm]:	Ø 32	Ø 32	Ø 32
Cylinder Bore 3rd Stage [mm]:	Ø 14	Ø 14	Ø 14
Medium:	Compressed Air / Breathing Air		
Intake Pressure:	atmospheric		
Oil Capacity [l]:	0,8	0,8	0,8
Intake Temperature [°C]:	-20 < +45	-20 < +45	-20 < +45
Ambient Temperature [°C]:	+5 < +45	+5 < +45	+5 < +45
Cooling Air Volume [m ³ /h] with 50 Hz / 60 Hz:	> 1050 / > 1260	> 1200 / > 1440	> 1650 / > 1980
Voltage:	E-Motor 230 - 440V / 3-Phases / 50-60 Hz	E-Motor 230 - 440V / 3-Phases / 50-60 Hz	E-Motor 230 - 440V / 3-Phases / 50-60 Hz
Protection Class Drive Motor:	IP 55	IP 55	IP 55
Drive Power [kW] with 50 Hz / 60 Hz:	3.5 / 4.2	4.0 / 4.8	5.5 / 6.6
RPM Motor [min ⁻¹]:	2890	2890	2890
Start:	Start / Stop switch		
Noise level [dB(A)]:	84	86	87
Dimensions L x W x H [mm]:	1060 x 500 x 580	1060 x 500 x 580	1060 x 500 x 580
Weight [kg]:	94	115	119
Content Volume Filter housing [l]:	0.46	0.69	0.69

DESCRIPTION

Unit Assembly

A



No.	Designation
1	Filling hose c/w filling valve and pressure gauge
2	Phase selector switch
3	Final filter c/w safety valve

DESCRIPTION

Phase selector switch

A

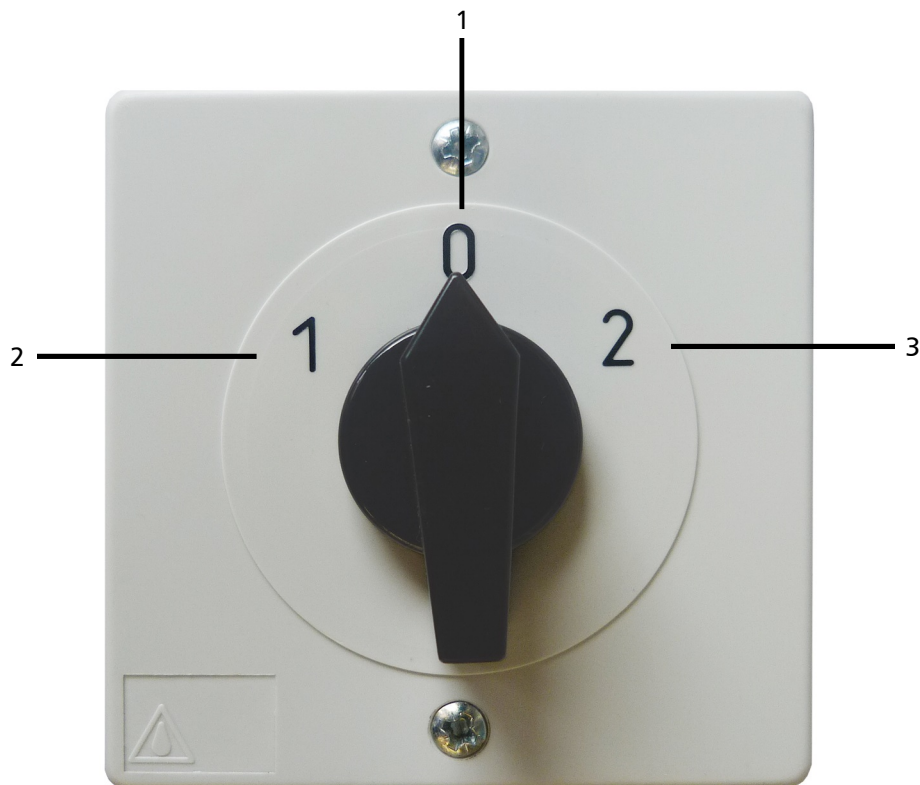

No.	Designation
1	Switch position 0 - OFF
2	Switch position 1 - ON - Rotation 1
3	Switch position 2 - ON - Rotation 2

DESCRIPTION

Flow chart

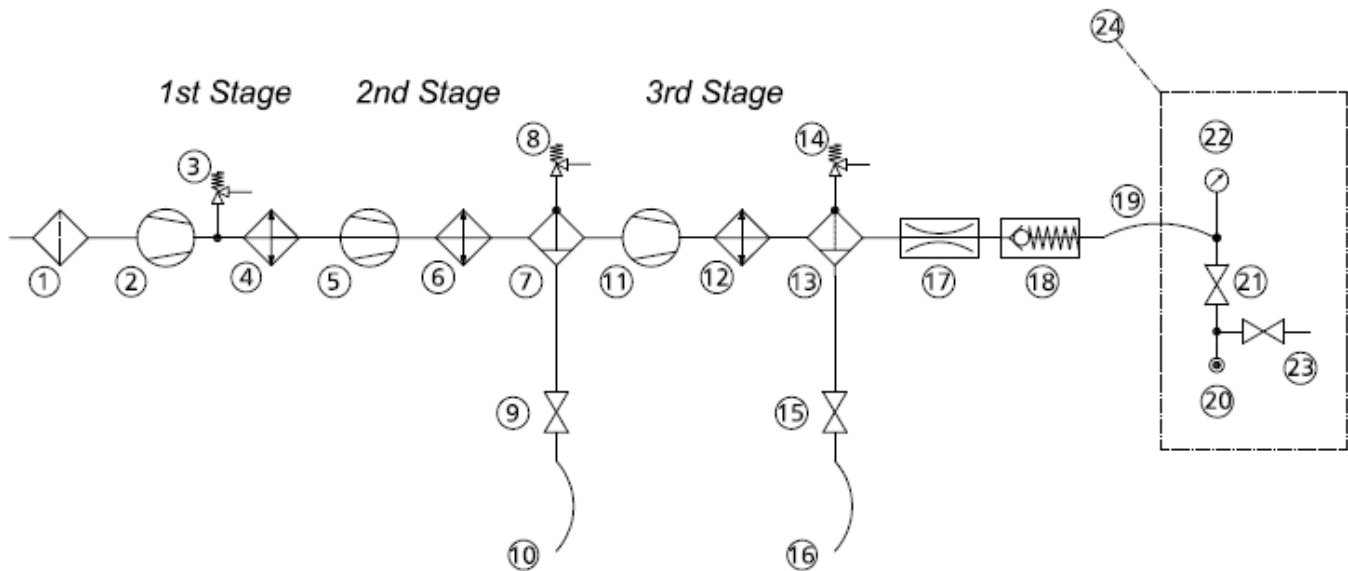

- | | |
|------------------------------|---------------------------------------|
| 1. Air Intake Filter | 13. Oil-/Water Separator |
| 2. 1st Pressure Stage | 14. Final Pressure-Safety Valve |
| 3. Safety Valve 1st Stage | 15. Condensate Release Valve |
| 4. Cooling Pipe 1st Stage | 16. Condensate Release Hose |
| 5. 2nd Pressure Stage | 17. Pressure Maintaining Valve |
| 6. Cooling Pipe 2nd Stage | 18. Non-Return Valve |
| 7. Oil-/Water Separator | 19. Filling Hose |
| 8. Safety Valve 2nd Stage | 20. Filling Connector |
| 9. Condensate Release Valve | 21. Filling Valve |
| 10. Condensate Release Hose | 22. Pressure Gauge (Filling Pressure) |
| 11. 3rd Pressure Stage | 23. Vent Valve |
| 12. Cooling Pipe Final Stage | 24. Unit Filling Valve "Cross Design" |



A

SAFETY PRECAUTIONS



SAFETY PRECAUTIONS

A

Intended Use

Only use the unit in perfect condition for its intended purpose, safety and intended use and observe the operating instructions! In particular disorders that may affect safety have to be eliminated immediately!

Use the unit exclusively for the determined medium (see "Technical Data"). Any other use that is not specified is not authorized. The manufacturer/supplier shall not be liable for any damages resulting from such use. Such risk lies entirely with the user. Authorization for use is also under the condition that the instruction manual is complied with and inspection and maintenance requirements are enforced.

No change and modification to the unit can be made without the written agreement of the manufacturer. The manufacturer is not liable for damage to persons or property resulting from unauthorised modifications.

Operators

Target groups in these instructions;

Operators

Operators are persons who are authorized and briefed for the use of the compressor.

Qualified personnel

Qualified personnel are persons who are entitled to repair, service, modify and maintain the system.



Warning

Only trained personnel are permitted to work on the unit!



Warning

Work on the electrical equipment on / with the machine / unit may only be carried out by qualified electricians.

SAFETY PRECAUTIONS

Safety instructions on the unit

Importance of notes and warning signs that are affixed to the compressor according to the application or its equipment.

A

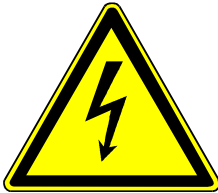

Warning
High voltage!



Note
Ensure correct direction of rotation!



SAFETY PRECAUTIONS

General Safety Precautions

- Read the Operating Instructions of this product carefully prior to use.
- Strictly follow the instructions. The user must fully understand and strictly observe the instructions. Use the product only for the purposes specified in the intended use section of this document.
- Do not dispose the operating instructions. Ensure that they are retained and appropriately used by the product user.
- Only trained and competent personnel are permitted to use this product.
- Comply with all local and national rules and regulations associated with this product.
- Only trained and competent personnel are permitted to inspect, repair and service the product.
- Only authentic L&W parts and accessories may be used for maintenance work. Otherwise, the proper functioning of the product may be impaired.
- Do not use faulty or incomplete products. Do not modify the product.
- Inform L&W in the event of any product or component fault or failure.
- The quality of the air supply must meet EN 12021 specifications for breathing air.
- Do not use the product in areas prone to explosion or in the presence of flammable gases. The product is not designed for these applications. An explosion might be the result if certain conditions apply.

A

SAFETY PRECAUTIONS

Unit customised safety notices

Organisational measures

- In addition to the instruction manual, observe and comply with universally valid legal and other obligatory regulations regarding accident prevention and environment protection.
- In addition to the instruction manual, provide supplementary instructions for supervision and monitoring duties taking into consideration exceptional factors e.g. with regard to organisation of work, production, personnel employed.
- Supervise personnel's work in accordance with the instruction manual, taking into account safety and danger factors.
- Observe all safety and danger notices on the compressor and check readability and completeness.

Safety instructions operation

- Take measures to ensure that the machine is only taken into operation under safe and functional conditions. Only operate the compressor if all protective and safety equipment, e.g. detachable protective equipment, are provided and in good working order.
- Check the compressor at least once per day for obvious damage and defects. Inform the responsible department / person immediately if anything is not as it should be (including operation performance). Shut down the machine immediately if necessary and lock it.
- In case of malfunction, stop the compressor immediately and lock it. Repair malfunctions immediately.
- If there is a failure in the electric energy supply, shut the machine / unit down immediately.
- Ensure safe and environmentally friendly disposal of consumables and old parts.
- The stipulated hearing protectors must be worn.
- Soundproofing equipment on the compressor has to be activated in safety function during operation.
- When handling with fats, oils and other chemical agents, observe the note for the product-related safety.



SAFETY PRECAUTIONS

Maintenance instructions

- Hoses have to be checked by the operator (pressure and visual inspection) at reasonable intervals, even if no safety-related defects have been detected.
- Immediately repair any damage. Escaping compressed air can cause injury.
- Depressurise system and pressure lines before beginning repair work.
- Pressurised air lines must be laid and mounted by qualified personnel. Connections must not be mixed up. Fittings, length and quality of the piping must correspond to requirements.
- Adjustment, maintenance and inspection activities and keep appointments, including information on replacement parts / equipment, prescribed in the operating instructions have to be respected.
- If the machine / equipment is completely off during maintenance and repair work, it must be protected against unexpected restart. Turn off main control device and remove the key and/or display a warning sign on the main switch.
- The machine and especially the connections and fittings should be cleaned from oil, fuel and maintenance products at the beginning of the maintenance / repair. Do not use aggressive cleaning agents. Use fibre-free cleaning cloths.
- Switch off compressor and clean with a slightly damp cloth. Remove dirt from cooling pipes by using a brush.
- After cleaning, examine all pipes for leaks, loose connections, chafing and damage. Immediately eliminate any faults.
- Always retighten any screw connections loosened for maintenance or repair work.
- If it is necessary to remove safety devices for maintenance and repair work, these must be replaced and checked immediately after completion of the maintenance or repair work.
- The electrical equipment of the compressor must be regularly checked. Defects, such as loose screw connections or burnt wires, must be immediately rectified by electrically skilled personnel.
- Only personnel with particular knowledge and experience with pneumatics may carry out work on pneumatic equipment.
- Only personnel with particular knowledge and experience in gas equipment may carry out work on gas equipment.

A



SAFETY PRECAUTIONS

Transportation instructions

- Parts which need to be dismantled for transport purposes must be carefully replaced and secured before taking into operation.
- The transport may only be carried out by trained personnel.
- For transportation, only use lifting devices and equipment with sufficient lifting power.
- Do not stand or work under suspended loads.
- Even minor relocation please disconnect the machine / system from any external energy supply.
- Before recommissioning, reconnect the machine to the mains according to regulations.
- When recommissioning, proceed according to the operating instructions..

Safety regulations

- Inspections according to legal and local obligatory regulations regarding accident prevention are carried out by the manufacturer or by authorised expert personnel. No guarantees whatsoever are valid for damage caused or favoured by the non-consideration of these directions for use.

A



A

INSTALLATION

INSTALLATION

Installation in closed rooms



Danger

No operation in explosion-hazard areas.

The unit is not approved for operation in areas prone to explosion.

For installation in closed rooms, observe the following:

- Install the unit horizontally and level. The floor must be vibration-free and capable of taking the load of the system weight.
- The compressor room must be clean, dry, dust free and as cool as possible. Avoid direct exposure to sunlight. If possible, install unit in such a manner that the compressor fan can intake fresh air from outside. Ensure adequate ventilation and exhaust air opening.
- When locating the compressor in rooms of less than 30 m³ space where natural ventilation is not ensured or other systems having high radiation are operating in the same room, measures must be taken to provide artificial ventilation.
- Intake air must be free from noxious gas e.g. smoke, solvent vapours, exhaust fumes etc.
- Observe the specified operating temperature (see "Technical Data")!

A

INSTALLATION

Dimensions LW 150 E MC

A

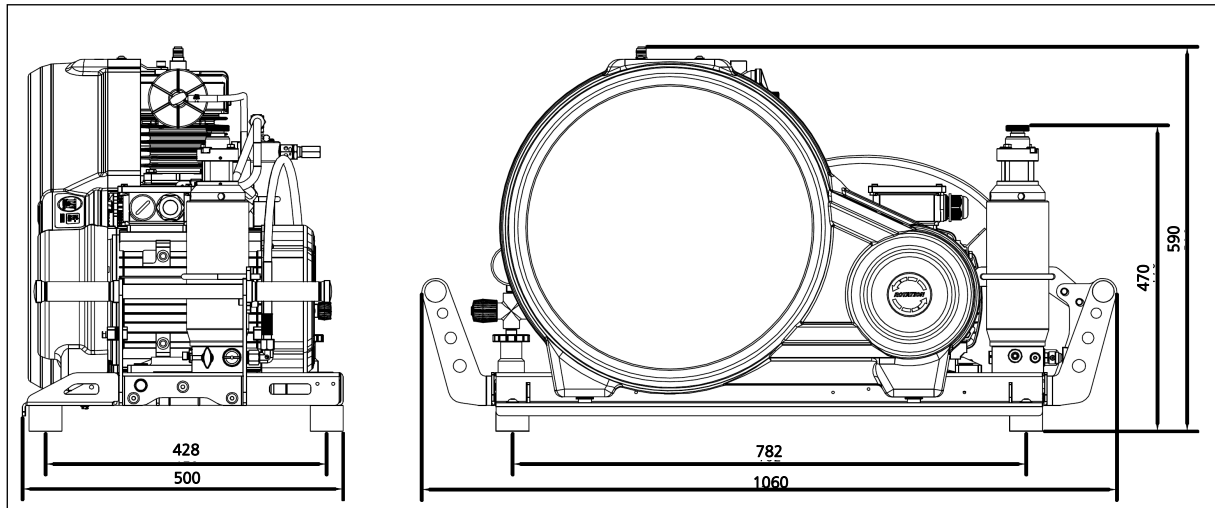

Fig. - Dimensions LW 150 E MC

Dimensions LW 200 E MC / LW 250 E MC

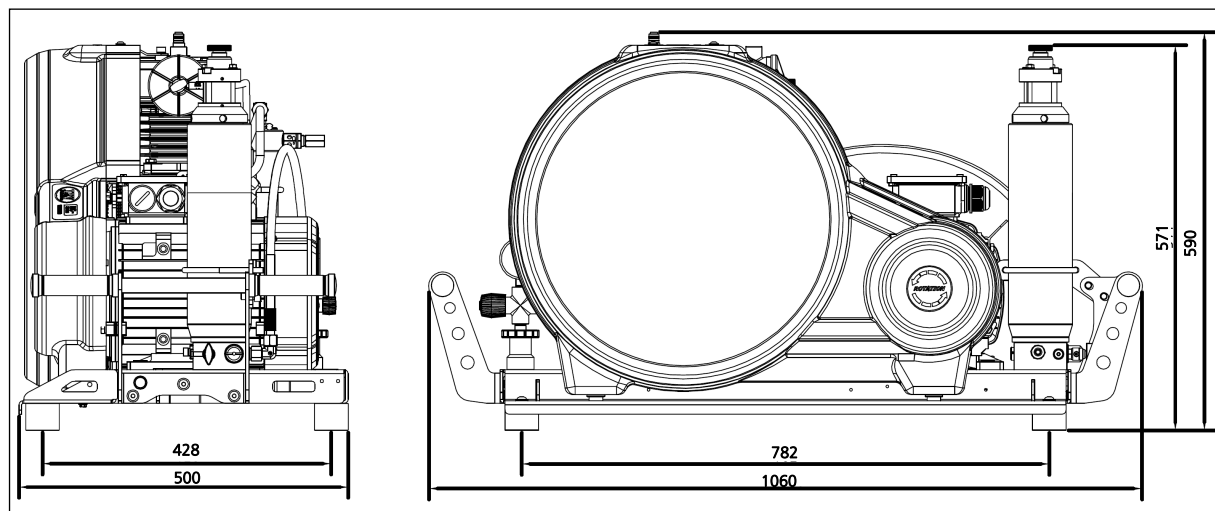

Fig. - Dimensions LW 200 E MC / LW 250 E MC

INSTALLATION

Minimum distances



Note

Minimum distances must be adhered!

- Make sure that the compressor always has a sufficient amount of fresh air available.
- To prevent serious damage, ensure that the cooling air flow can flow freely.
- The following minimum distances must be adhered:
Front side min. 1500 mm, sides min. 500 mm, rear side min. 500 mm.
Avoid anything in this area which can restrict the cooling air flow.

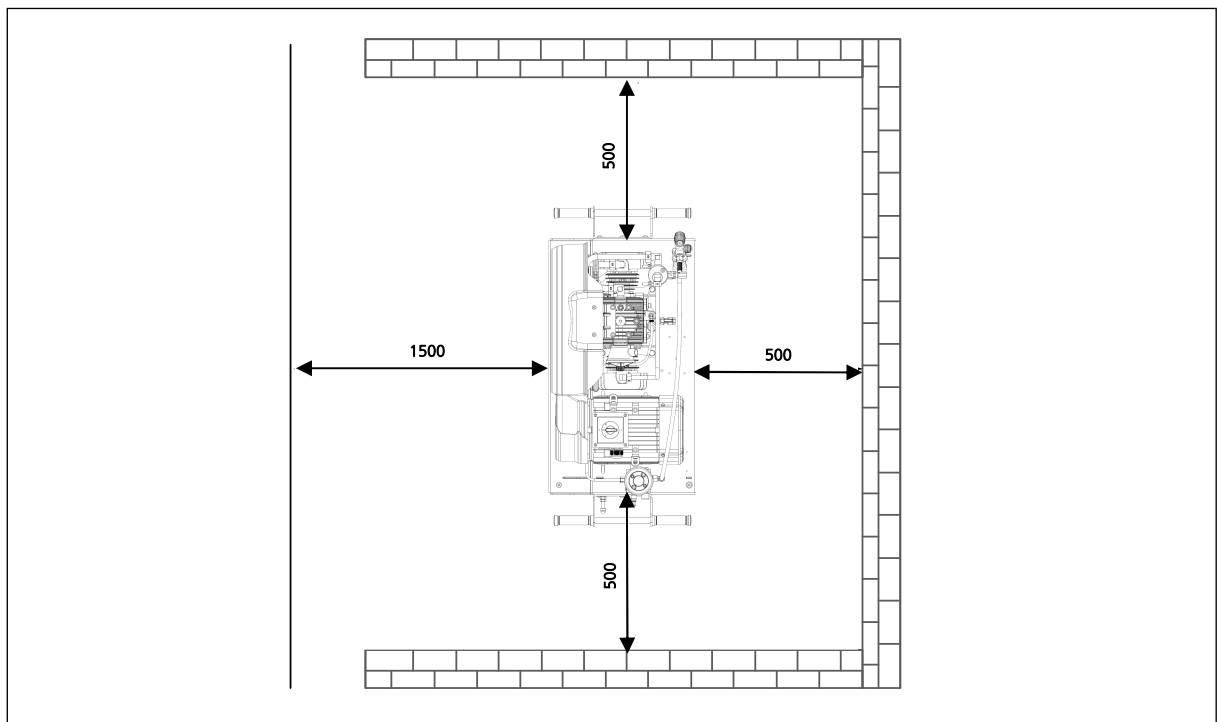

Fig. - Minimum distances

INSTALLATION

Ventilation

- Make sure that the compressor always has a sufficient amount of fresh air available for cooling.
- To prevent serious damage, ensure that the cooling air flow can flow freely.
- The necessary cooling air flow can be calculated by using the following formula:
 $300 \times \text{drive power [kW]} = \text{required cooling air flow [m}^3/\text{h]}$
 Example 11kW motor: $300 \times 11\text{kW} = 3300 \text{ m}^3/\text{h} = \text{required cooling air flow.}$
- The fan capacity for fresh air and warm air must meet at least the required cooling air flow.
 The fans must have the same capacity.

A

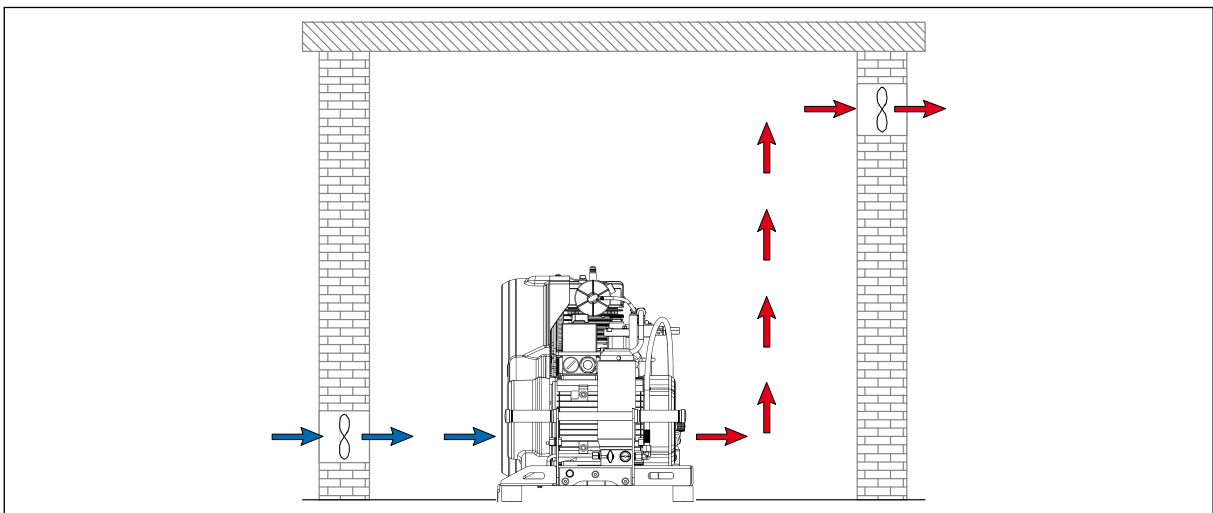

Fig. - Ventilation through facade

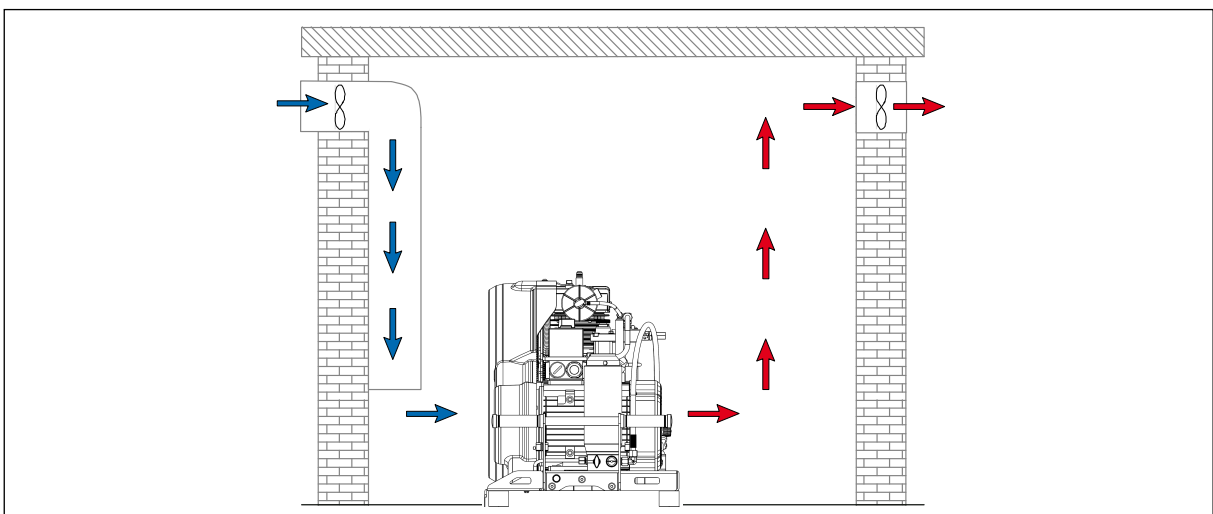

Fig. - Ventilation via ventilation stack

INSTALLATION

Electrical Installation



Warning

Work on the electrical equipment on / with the machine / unit may only be carried out by qualified electricians.

For installation of electrical equipment, observe the following:

- If control devices are delivered by the factory, refer to the appropriate wiring diagram.
- Ensure correct installation of protective conductors.
- Check conformity of motor and control device tension and frequency with those of the electric network (see name plate on the compressor).
- The fusing should be done in accordance with the valid regulations of the responsible electricity supply company.
- When connecting the unit to the electrical supply, check the compressor direction of rotation (see chapter "Operation -> First commissioning).
- Fuse the motor correctly (see table; use slow-blow fuses).

INSTALLATION

Electrical Installation

The standard compressor version is prepared for the connection to three phases (brown, black, grey), neutral conductor (blue) and protective earth conductor (green/yellow).

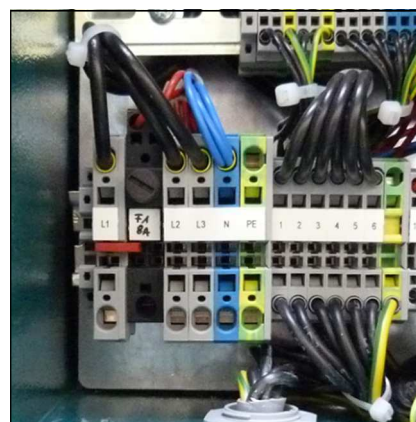

A

Recommended fuses for 360 - 500 V operating voltage

Nominal motor power		Fusing start A		Connection in mm ²	
[kw]	[A]	Direct	Star/Delta	Contactor supply	Motor S/D
3	5.9	16	-	2.5	1.5
4	8.5	20	-	2.5	1.5
5.5	11.3	25	20	2.5	1.5

Recommended fuses for 220 - 240 V operating voltage

Nominal motor power		Fusing start A		Connection in mm ²	
[kw]	[A]	Direct	Star/Delta	Contactor supply	Motor S/D
3	10.3	20	-	2.5	1.5
4	14.8	25	-	2.5	1.5
5.5	19.6	35	25	4	2.5



A

OPERATION

OPERATION

Important operation instructions



Note

Ensure that all persons handling the compressor are familiar with function and operation of the unit.



Wear hearing protection

When working on a running machine, always wear hearing protection.

A

FIRST COMMISSIONING

A

Prior to first commissioning, observe the following:

- Ensure that cooling air can flow freely.
- Check compressor oil level (see "Service and Maintenance").
- Check all connections and retighten if necessary.
- Check if the filter cartridge is in place (see "Service and Maintenance").
- Check the V-belt tension (see "Service and Maintenance").
- Check if all filling valves are closed. Open one filling valve and hold tight manually!

Kompressor starten

1. Start the compressor by switching position 1 of phase selector switch.
2. Check turning direction - see the rotary direction arrow on the compressor block (see next pages). If the turning direction is wrong, immediately stop the compressor by switching in position 0 and start the compressor by switching in position 2.



Warning

Wrong impeller rotation direction!

Immediately after switching the compressor on, check the rotation direction. Depending on the place of installation, the phase sequence can influence the rotation direction.

3. Run the compressor for about 2 minutes.
4. Close the open filling valve carefully.
5. Run the compressor up to maximum pressure and check the function of the final pressure safety valve. If the compressor is equipped with an automatic stop system please check the automatic shut down at final pressure. If the final pressure switch does not shut off, switch off the compressor by placing the switch at position 0 (see chapter "Remedying faults").
6. Check the compressor unit for leaks (see "Service and Maintenance").
7. Check the condensate drain valves:
Standard: Open the condensate drain valves carefully (see "Service and Maintenance").
Option: Automatic condensate drain:
 - Fix the black condensate hoses
 - Drain test - press the test button
 - If correct, air escapes
8. Stop the compressor by switching in position 0.
9. Open all filling valves carefully to vent.

FIRST COMMISSIONING

Check turning direction

Before starting the compressor for the first time, check rotation direction (see the rotary direction arrow on the housing of the electric motor).

If the direction of rotation is wrong, the guide pistons of the 2nd and 3rd stages can not be sufficiently lubricated, with the consequence that the pistons will be damaged. Furthermore, cooling air flow will not be sufficient.



Rotation direction arrow on the fan protection cover.

A



Warning

Wrong impeller rotation direction!

Immediately after switching the compressor on, check rotation direction. Depending on the place of installation, the phase sequence can influence the rotation direction.

Rotation direction change



Warning

Work on the electrical equipment on / with the machine / unit may only be carried out by qualified electricians.

In case of a wrong rotation direction there is the possibility to change the switching position of the phase selector switch. In case of wrong rotation direction in switching position 1, start the compressor in switching position 2. In case of wrong rotation direction in switching position 2, start the compressor in switching position 1.



DAILY COMMISSIONING

Prior to daily operation observe the following:

- Ensure cooling air can flow freely.
- Check compressor oil level by the oil sight glass.
- Check if filter cartridge is in place / observe filter cartridge life!
- Ensure toxic-free, pure intake air.

A

OPERATION

Filling procedure

**Caution! Fill only cylinders which:**

- are marked with the test mark and the test stamp of the expert.
- have been hydrostatic tested (check last test date).
- are rated for the final pressure.
- are free from humidity.

**Note**

The unit must be stopped manually when final pressure is reached. No serial auto shut down. The unit must also be started manually.

**Caution**

Vent condensate drain valves every 15-30 minutes manually.

1. Close all filling valves.
2. Connect the closed compressed air cylinders.
3. Open cylinder valves.
4. Open the condensate drain valves during the starting process and start the compressor
5. When filling pressure gauge increases, open filling valves slowly.
6. Fill the compressed air cylinders to the desired pressure; close slowly the valves of the cylinders.
7. Switch off the compressor.
8. Close and vent all filling valves.
9. Disconnect all compressed air cylinders from filling valves.
10. Open condensate drain valves manually.

OPERATION

Switch off the compressor



Note

After switching off, open condensate drain valves manually to vent the unit.

The compressor unit is not equipped as standard with an auto shut down. The unit must always be stopped manually when final pressure is reached.

During filling process, the system can be shut down at any time by switching the phase selector switch in position 0.

Switch off the compressor unit

- Stop compressor by switching the phase selector switch in position 0.

A



A

REMEDYING FAULTS

REMEDYING FAULTS

Final pressure can not be reached

Cause of fault	Remedy
Connections leaky	Retighten or clean/replace if necessary
Final pressure safety valve leaky	Replace, turn out vent screw if necessary
Pipes / heat exchanger broken	Replace
Condensate drain valves leaky	Unscrew valves, check sealing surfaces, clean, replace if necessary
Final pressure switch stop unit	Verify settings, replace if necessary
Piston of automatic condensate valve sticks (Only valid with the option - Automatic Condensate Drain)	Clean automatic condensate valve and restore function, check/replace o-rings, replace valve completely if necessary

Strong compressor vibration

Cause of fault	Remedy
V-belt tension too loose	Tension V-belt
Drive motor / Compressor unit loosely	Retighten mounting screws
Anti vibration mounts used up	Replace
Ground not levelled	Ensure a solid and level ground

Air supply too low

Cause of fault	Remedy
Inlet and outlet valves contaminated / defective	Clean, replace if necessary
Cylinder(s), piston(s) or piston ring(s) used up	Replace
V-belt slips	Tension V-belt
See chapter "Final pressure can not be reached"	See chapter "Final pressure can not be reached"

REMEDYING FAULTS

Compressor overheated

Cause of fault	Remedy
Inlet filter cartridge contaminated	Replace
Ambient temperature too high	Improve room ventilation / Reduce operation times
Cooling air inlet and outlet insufficient	Observe minimum distances (see Installation Instructions)
Air intake hose too long	Reduce length of the air intake hose
Air intake hose diameter too small	Use a larger diameter
Wrong compressor rotation direction	Ensure correct phase rotation, observe rotation direction arrow!
Inlet and outlet valves contaminated / defective	Clean, replace if necessary

Safety valve leaks

Cause of fault	Remedy
Inlet and outlet valves of the following pressure stage defective	Clean, replace if necessary
Sinter filter of the following water separator blocked	Replace
Safety valve leaky	Replace, turn out vent screw if necessary

Oil taste in the air

Cause of fault	Remedy
Mole carbon filter cartridge saturated	Replace
Compressor oil unsuitable	Use prescribed oil quality
Filter cartridge unsuitable	Use prescribed filter type
Cylinder(s), piston(s) or piston ring(s) defective	Replace

REMEDYING FAULTS

Automatic condensate drain defective

Only valid with the option - Automatic Condensate Drain

Cause of fault	Remedy
Solenoid coils defective	Replace
Cable / supply cable defective	Repair, replace if necessary
Timer / relais defective	Replace
Sinter filter of automatic condensate valve blocked	Replace
Automatic condensate drain piston sticks	Clean automatic condensate drain valve and restore function, check/replace o-rings, replace valve complete if necessary

Condensate drain starts before reaching final pressure

Only valid with the option - Automatic Condensate Drain

Cause of fault	Remedy
Pressure stages are not as prescribed, control pressure of automatic condensate valve too low	Check corresponding inlet and outlet valve, replace if necessary.
Piston sealing of automatic condensate valve contaminated / used up	Clean, replace if necessary
Timer / relais settings not correct	Adjust as prescribed
Timer / relais defective	Replace

Compressor stops before final pressure

Only valid with the option - Automatic Condensate Drain

Cause of fault	Remedy
Final pressure switch settings not correct	Correct settings
Opening pressure of the pressure maintaining valve too high	Correct settings
Fuse / circuit breaker has tripped Valid only for E models	Check fusing of the power supply / observe regulations

REMEDYING FAULTS

Filter life not sufficient

Cause of fault	Remedy
Pressure maintaining valve settings not correct	Adjust as prescribed
Filter cartridge unsuitable	Replace by a prescribed filter cartridge type
Filter cartridge too old	Observe expiration date
Filter cartridge packaging incorrect / damaged / already opened. Filter cartridge already partly saturated before change	Store filter cartridges properly, dispose defective cartridges
Operating temperature too high	Ensure sufficient ventilation
Cylinder(s), piston(s) or piston ring(s) defective	Replace

Oil consumption too high

Cause of fault	Remedy
Cylinder(s), piston(s) or piston ring(s) defective	Replace
Compressor oil unsuitable	Use prescribed oil quality
Operating temperature too high	Observe prescribed operating temperatures
Oil leak at the compressor block	Tighten corresponding mounting screws, if necessary replace corresponding paper sealing / o-ring / shaft seal



A

MAINTENANCE AND SERVICE

MAINTENANCE AND SERVICE

Service, Repair and Maintenance

Carry out service and maintenance work exclusively when the compressor is stopped and depressurised. The unit should be leak-checked regularly. Leaks can be preferably localised by using a leak detector spray (if necessary, brush pipes with soapy water).

We recommend that only authorised L&W service technicians carry out service work on the bearing of the compressor (crankshaft and connecting rods).

We urgently recommend that all maintenance, repair and installation work must only be carried out by trained personnel. This is necessary because all maintenance work can not be explained exactly and detailed in this manual.

Only use authentic spare parts for service work.



Danger

Components under pressure, such as hose ends, can quickly come loose when manipulated and can cause potentially fatal injuries due to the pressure surge. Any work on system parts may only be performed in a pressure-compensated state.



Warning

The use of accessories that have not been tested can lead to death or serious injury or damage to the unit. Only use authentic spare parts for service work.



Warning

Carry out maintenance or service work when the unit is switched off and protected against unexpected restart.



Warning

Risk of burns!

Carry out maintenance or service work when the unit has cooled down.



MAINTENANCE AND SERVICE

Daily before taking unit into operation

Maintenance work	Type	Quantity	Order No.
Check oil level	-	-	000001
Check condition of all filling hoses	-	-	-
Check filter cartridge lifetime	LW 150 E MC	1	000644
	LW 200/250 E MC	1	011174
Operate unit to final pressure and check function of final pressure switch	-	-	-

At 25 operating hours

Maintenance work	Type	Quantity	Order No.
Oil change	-	0.8	000001

Weekly or as needed

Maintenance work	Type	Quantity	Order No.
Check automatic condensate drain, open manual condensate taps	-	-	-
Check/Retorque all connections and bolts	-	-	-
Check V-belt tension and condition	-	-	-

Annually

Maintenance work	Type	Quantity	Order No.
Oil change, if less than 1000 operating hours	-	0.8 ltr	000001
Check opening pressure of final safety valve	-	-	-
Clean coolers	-	-	-
Clean all oil/water separators, if less than 500 operating hours	-	-	-
Service intake filter (depends on condition - if less than 500 operating hours)	-	-	-

A



MAINTENANCE AND SERVICE

Every 500 operating hours

Maintenance work	Type	Quantity	Order No.
Check V-belt tension and condition	LW 150 E MC (50Hz / 60Hz)	1	003694
	LW 200 E MC (50Hz / 60Hz)	1	003694
	LW 250 E MC (50Hz)	1	011154
	LW 250 E MC (60Hz)	1	001685
Change intake filter	-	1	001708
Check pressure maintaining / non-return valve	-	-	-
Check all connections for leaks	-	-	-
Clean oil/water separators	-	-	-

Every 1000 operating hours

Maintenance work	Type	Quantity	Order No.
Replace o-ring of the DIN filling connector	-	1	001237
Replace o-ring of the revolvable filling hose	-	1	001224
Replace sintered metal filter of oil separator	-	1	002123
Replace o-ring of the water separator	-	1	001255
Replace o-ring of the final filter housing	-	2	001769
Oil change	-	0.8	000001

A



MAINTENANCE AND SERVICE

Every 2000 operating hours

Maintenance work	Type	Quantity	Order No.
Replace o-rings and gaskets of 1st, 2nd and 3rd stage	O-Ring (1st stage)	1	011104
	O-Ring (2nd + 3rd stage)	2	011105
Replace all inlet and outlet valves incl. Gaskets	1st stage	1	003652
	2nd stage	1	000551
	3rd stage	1	011123
	Upper gasket 1st	1	003651
	Lower gasket 1st	1	011103

A

MAINTENANCE AND SERVICE

Service Kits

The service kits contain parts for maintenance according to the factory requirements.

The use of the service kits ensures that all required parts are ordered and replaced and gives assurance that all parts are included in the order. Depending on the model and interval, the service kits include parts such as O-Rings, Sinter Filter, Inlet Filter, V-Belts, Silencers, In-&Outlet Valve, Valve Seals and Compressor oil.



Service Kits mounting screws of the motor flange

A

Service Kits

Compressor	Operating Hours	Order No.
LW 150 E MC / LW 200 E MC / LW 250 E MC	1000 h	011169
LW 150 E MC / LW 200 E MC / LW 250 E MC	2000 h	011170

MAINTENANCE AND SERVICE

Check V-belt tension

The LW 150 E MC / 200 E MC / 250 E MC compressors are driven by V-belts. Check correct V-belt tension regularly, adjust if necessary. The V-belt could lose tension during transportation. Please check the V-belt tension before starting the compressor.

Tension V-belts

- Switch off the compressor unit, pull the plug if necessary.
- Tilt the compressor slightly aside.
- Loosen mounting screws (SW17) of the motor flange (Fig. 1).
- Turn clamp nut (SW17) until correct V-belt tension (Fig. 2).

Rotation direction clockwise: increase V-belt tension.

Rotation direction anti-clockwise: reduce V-belt tension.

- Tighten mounting screws of the motor flange.
- Check V-belt tension and adjust if necessary.

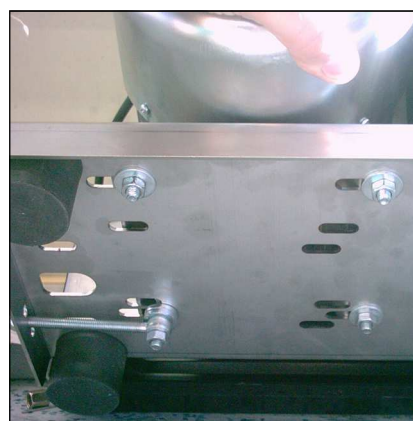

Fig. 1 - Loosen mounting screws of the motor flange

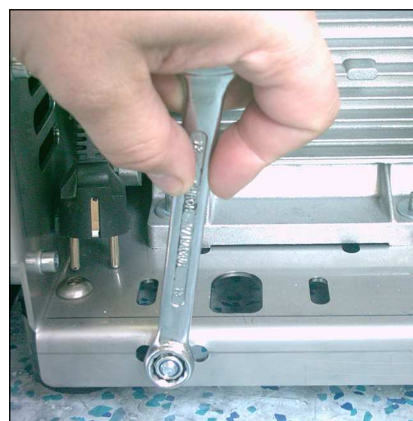

Fig. 2 - Turn clamp nut until correct V-belt tension

Correct V-belt tension

Do not tension V-belts too tight. This damages bearings of compressor and motor. The V-belt should only be tensioned until there is no noise caused by slipping during start.

We recommend using a V-belt tension gauge.

Settings for V-belt tension

Motor Type	Initial Installation	Operation after running in
Electric motors 50Hz	500 N	400 N
Electric motors 60Hz	400 N	300 N

MAINTENANCE AND SERVICE

Compressor Lubrication

Pistons, cylinders, crankshaft and connecting rods are provided with oil by splash lubrication.

A

Check oil level



Warning

Check oil level daily. Never start the compressor with a too low oil level. Risk of accidental loss, destruction or deterioration.

Check oil before each operation of the system!

The oil level should be between the middle and upper end of the oil sight glass. Never start the compressor with a too low oil level.

Refill new compressor oil at least when the oil level reached the middle of the indicated area.

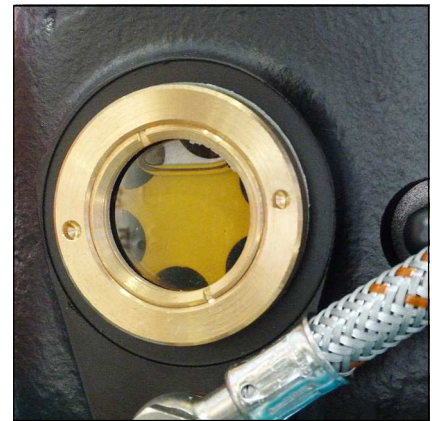

Oil sight glass



Warning

- First oil change after 25 operating hours.

Oil change



Note

We recommend oil change at least once a year - depending on total operating hours.

Oil change as follows:

- Run compressor warm for about 2 minutes.
- Switch off and vent compressor.
- Tilt the compressor aside.
- Place a suitable oil drain tray under the drain plug.
- Screw off oil drain plug carefully and remove oil fill port.
- Drain oil.
- Screw in oil drain plug and tighten
- Fill oil into the nozzle by a funnel.
- Check oil level. The oil level should be between the middle and upper end of the oil sight glass.
- Screw oil fill port manually in and tighten.

The oil change is now completed.

Maintenance intervals

- First oil change at 25 operating hours (total hours).
- Second oil change at 1000 operating hours (total hours).
- All further changes after each 1000 operating hours.

Oil and oil capacity

Approx. 800 ml synthetic compressor oil is necessary for one oil change. Only use synthetic compressor oil which is recommended as suitable from L&W. (P/N: 000001)

Manual condensation dump system



Note

The collected condensate can contain oil and has to be disposed according to regulations.

Oil- / water separators

The compressor comes as standard with a manual condensation dump system. Drain condensate separators every 15 to 30 minutes, depending to air moisture.

Option Automatic Condensate Drain: To release the complete condensate through the black plastic hoses we recommend using a 20 l container at least.

The drain noise can be kept to a minimum by using a silencer.

Manual drain



Warning

Open valve spindle max. 1.5 turns.
The pressure in the housing can shoot out the valve spindles at high speed.



Fig. 1 - Condensate drain valve
2nd.stage



Fig. 2 - Condensate drain valve 3rd.stage

To drain manually, open the condensate drain valve of the 2nd stage oil / water separator and the condensate drain valve of the filter housing (Fig. 2).

Open valve spindle max. 1.5 turns anti-clockwise. The condensate will be drained.

Then close valve spindle clockwise.

Maintenance intervals

We recommend to clean oil and water separators every 500 operating hours or at least once a year, to check for corrosion damage and to replace o-rings if necessary.

The oil / water separator has an integrated sinter filter which has to be replaced every 1000 operating hours.

Oil / water separators 2nd stage - maintenance



Note

Clean all parts thoroughly before assembly.

Maintenance / cleaning of oil / water separator 2nd stage as follows:

- Loosen pipe connections (Fig. 1)
- Loosen screw connection at the water separator (sinter filter holder)
- Remove sinter filter holder (Fig. 2).
- Change sinter filter (Fig. 3), screw-in new sinter filter by using a suitable screwdriver.
- Change o-ring, previously grease new o-ring (Fig. 4)
- Place sinter filter holder into the water separator and tighten
- Connect pipe connections and tighten.

The oil / water separator maintenance is now completed.

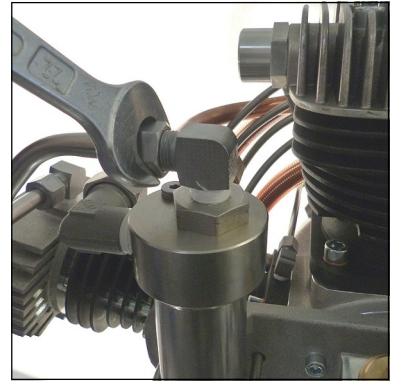

Fig. 1 - Loosen pipe connections

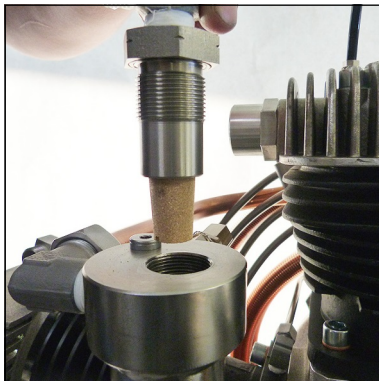

Fig. 2 - Remove sinter filter holder



Fig. 3 - Change sinter filter



Fig. 4 - Change o-ring

MAINTENANCE AND SERVICE

Filter housing

The mole carbon filter housing is installed on the right hand side of the compressor housing.

Inside the filter housing a jet blows air on to the housing wall. Condensation water and oil are led by centrifugal force to the bottom of the housing. Air flows through the mole carbon filter cartridge, which purifies the air from residual moisture and odours.



Fig. Filter housing

Filter cartridge

The high-pressure compressor is equipped with an integrated breathing air purification system. Air is compressed up to 330 bar, dried and odour- and tasteless purified. Oil residues are bounded. The breathing air filter cartridge consists of a molecular sieve and activated-carbon filter.

All breathing air filter cartridges are factory vacuum sealed.

We recommend unpacking the filter cartridges just before installation. Filter cartridges which are exposed too long could be saturated with moisture and become unusable.

Maintenance Intervals

Filter cartridges should be changed at the following intervals, at +20°C or more often, depending on humidity and ambient temperature:

- 12 hours for LW 150 E MC (Order No.: 000644)
- 41 hours for LW 200 E MC (Order No.: 011174)
- 33 hours for LW 250 E MC (Order No.: 011174)

MAINTENANCE AND SERVICE

Filter cartridge change

Filter cartridge change as follows:

- Stop the compressor and open carefully the drain valves. Please wait till the filter housing is completely vented; this procedure takes approx. 1 - 2 minutes
- When no air discharges from the condensate release hoses, the pressure vessels are depressurized.
- Remove the end filter cover (Fig. 1 / Fig. 2). Remove the filter cover by using the filter tool. The housing can not be opened when it is still under pressure.
- After opening the housing, pull out the filter cartridge by the catch (Fig. 3).
- Open the packaging of the new filter cartridge and place it into the filter housing (press slightly).
- Screw the filter housing cover in by using the filter tool and turn it back 1/4 turn. This avoids tightening of the cover due to vibration.

The filter cartridge change is now completed.



Note

Ensure that the old filter cartridge is disposed correctly at an approved waste point.



Fig. 1 -Loosen filter housing cover by using the filter tool

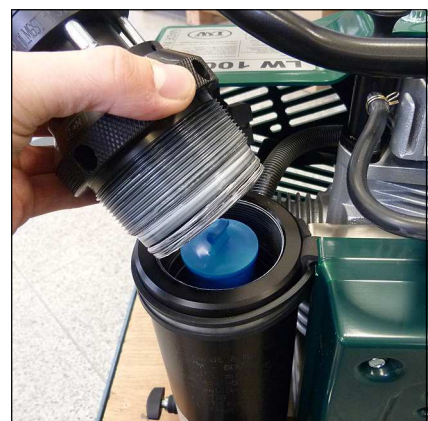

Fig. 2 - Remove filter housing cover



Fig. 3 - Pull out the filter cartridge by the catch and insert a new cartridge

A

Filter housing - maintenance



Note

Clean all parts thoroughly before assembly.

Filter housing maintenance as follows:

- Unscrew filter housing cover by using the filter tool (Fig. 1).
- Change o-ring, previously grease new o-ring (Fig. 2)
- Screw the filter housing cover in by using the filter tool (Fig. 1).

The filter housing maintenance is now completed.



Fig. 1 - Remove/screw in filter cover



Fig. 2 - Change o-ring

Inlet Filter

**Note**

Dirty filters make air intake difficult and reduce delivery capacity. Risk of compressor overheating.

A paper dry filter is used for the inlet filter. Check air inlet filter regularly or replace it. Depending on the degree of contamination, the filter inlet can be cleaned by compressed air. Defective air inlet filters should be immediately replaced with a corresponding filter.

Maintenance intervals

We recommend that the filter cartridge should be replaced every 500 working hours (depending on pollution grade).



Inlet Filter

Check or change filter inlet



Note

Clean all parts thoroughly before assembly.

To properly change the filter inlet, proceed as follows:

- Disconnect the crankcase housing at the ventilation hose (Fig. 1).
- Remove mounting screw and pull out filter housing carefully (Fig. 2).
- Clean filter housing and o-rings and check if defective (fissures).
- Place o-ring into the housing (Fig. 3).
- Insert the new cartridge and assemble the housing. Place o-ring into the groove (Fig. 4).
- Place and align the filter housing carefully, inlet port up, hose connector 90° turned to the left (Fig. 5).
- Tighten mounting screw and connect the crankcase housing ventilation hose to the oil fill port (Fig. 6).

The filter inlet change is now completed.



Fig. 1 - Pull off ventilation hose at the oil fill port

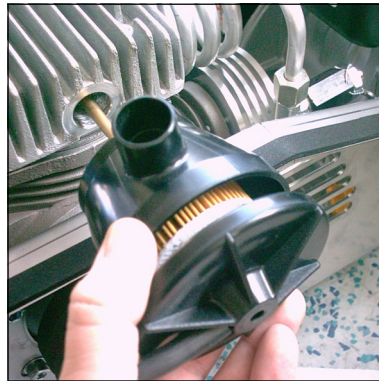

Fig. 2 - Pull out filter housing carefully



Fig. 3 - Place o-ring into the filter housing



Fig. 4 - Place o-ring into the groove

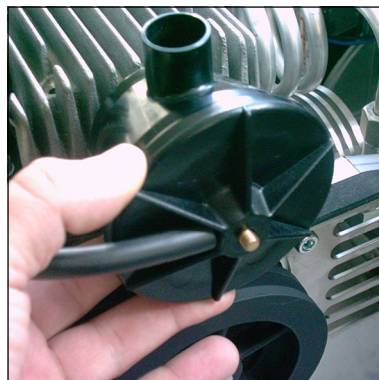

Fig. 5 - Place and align filter housing carefully

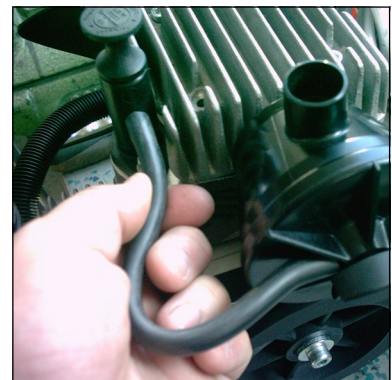

Fig. 6 - Connect ventilation hose at the oil fill port

MAINTENANCE AND SERVICE

Cylinder heads and valves

Inlet and outlet valves of the specific compressor stages are located between valve head and cylinder. Outlet valves open while piston upstroke or compression stroke, inlet valves open while downstroke.

Valves are subject to normal wear and tear and have to be replaced at certain intervals (depending on specific operating conditions). Dismount valve heads to change valves. The three valves are combined inlet and outlet valves. The first stage is a plate valve. The stages two and three are made of a spring operated piston which acts inside a bronze cylinder.



Inlet and outlet valve incl. gaskets of the 3rd stage

Maintenance intervals

All valves should be replaced after 2000 working hours due to normal wear and tear. To replace valves the cylinder heads have to be removed. There are no special tools required to replace these valves.

Available special tools

Special tools are not necessary for dismounting inlet and outlet valves but make work easier.

Order number: 006847



Special tool

Replace in- and outlet valve 1st stage



Note

The figures of the parts can differ due to the different stages.

Replace the inlet and outlet valve 1st stage as follows:

Remove inlet / outlet valve

- Loosen mounting screws of the fan protection cover bracket (Fig. 1) and remove fan protection cover.
- Remove spring wire clamp of the crankcase ventilation hose (Fig. 2).
- Remove hose.
- Loosen pipe connections.
- Loosen valve head screws.
- Remove valve head and check if defective.
- Remove upper valve head gasket and inlet / outlet valve.

Install inlet / outlet valve - see following page



Fig. 1 - Loosen mounting screws of the fan protection cover



Fig. 2 - Remove spring wire clamp



Fig. 5 - Remove in- and outlet valve

MAINTENANCE AND SERVICE

Replace in- and outlet valve 1st stage



Note

The figures can differ from the delivered parts.

Replace the inlet and outlet valve 1st stage as follows:

- Insert lower valve gasket (Fig.1).
- Insert upper valve gasket (Fig.2).
- Insert in- and outlet valve. CAUTION: Observe correct position between valve centre hole and valve head locating pin (Fig. 2+3).
- Place valve head carefully on top of the cylinder (take care to keep valve in place) (Fig.4)
- Tighten valve head screws crosswise.
- Set tight connecting nut and fix vent hose to air intake housing. Don't forget to fix spring wire clamp.



Fig. 1 - Lower valve gasket



Fig. 2 - Correct position of in-and outlet valve

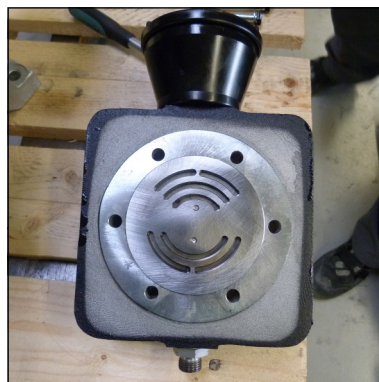

Fig. 3 - Correct position of in-and outlet valve

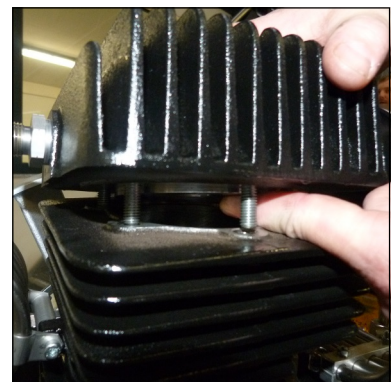

Fig. 4 - Take care to kkeep valve in place

Replace inlet and outlet valve 2nd stage / 3rd stage



Note

The figures of the parts can differ due to the different stages.

Replace the inlet and outlet valve 2nd stage as follows:

- Loosen pipe connections.
- Loosen valve head screws.
- Remove valve head Observe that the lower valve gasket is also pulled out. It can still stick inside the cylinder head.
- Remove inlet / outlet valve.
- Check valve head if defective (check locating pin).
- Change upper valve gasket.
- Change lower valve gasket (aluminium gasket).
- Insert new inlet and outlet valve into the valve head (Fig. 1). CAUTION: Observe correct position between valve centre hole and valve head locating pin.
- Place the valve head with the new inlet and outlet valve.
- Place pipe connections.
- Tighten valve head screws crosswise.
- Tighten pipe connections.

Inlet and outlet valves change 2nd stage / 3rd stage is now completed.



Fig. 1 - Ensure correct valve position (centre pin)

Safety valves

Every pressure stage is equipped with a separate over pressure safety valve. Safety Valves avoid a non permissible high pressure at the specific pressure stages and limit maximum operation pressure of the compressor.

Safety valves are adjusted to:

- 1st Stage: 8 bar
- 2nd Stage: 70 bar
- 3rd Stage: max. final pressure

The adjusted blow-off pressure [bar] of the safety valves is indicated on their housings.

All safety valves are factory sealed with special L&W safety seals to avoid manipulation of the limit value settings.

Safety valves with removed seals have to be immediately checked for the prescribed settings and replaced if necessary.

The safety valve of the final stage is furthermore equipped with a knurled screw to be activated once. Turning the knurled screw clockwise could vent the valve completely and therefore the final filter housing.

During normal operation conditions, the knurled screw has to be turned anti-clockwise up to the upper stop. An integrated circlip avoids complete unscrewing.

If a safety valve blows off, it indicates problems with either inlet or outlet valve of the following stage.



Note

Replace defective safety valves immediately!

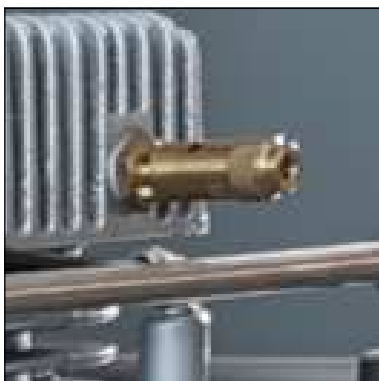

Safety valve 1st stage



Safety valve 2nd stage



Safety valve 3rd stage

MAINTENANCE AND SERVICE

Pressure maintaining / non return valve

The pressure maintaining / non return valve combination is placed in the flow direction after the final filter housing.

Pressure maintaining valve

The pressure maintaining valve drains a large part of the water content of the compressed air mechanically by ensuring the minimum outlet pressure. This guarantees optimal drying and purification of the breathing air.

After starting the compressor, the pressure inside the final filter housing constantly increases. The pressure maintaining valve prevents the compressed air from blowing off (final pressure gauge = 0 bar).

When the adjusted opening pressure is reached (160 bar), the purified compressed air flows via pressure maintaining and non return valve to the filling valve.

The value of the opening pressure of the pressure maintaining valve can be read at the final pressure gauge. When opening pressure is reached, the pressure gauge value increases within a few seconds.

Adjust pressure maintaining valve see next page.

Non return valve

The non return valve which is placed after the pressure maintaining valve, prevents the purified breathing air from flowing back into the filter housing / condensate drain valves.

After compressor stop, the indicated filling pressure remains constant, if the non return valve is working correctly.



Drain valve and pressure maintaining / non return valve

A

Adjust pressure maintaining valve

- Vent filling valve and close afterwards (filling pressure gauge 0 bar)
- Start the compressor
- Observe filling pressure gauge
- When the opening pressure of the pressure maintaining valve is reached, the indicated filling pressure increases within some seconds from 0 bar up to the adjusted opening pressure.

If the opening pressure does not reach a value of 160 bar, adjust the pressure maintaining valve as follows:

Increase opening pressure:

- Vent filling valve (filling pressure 0 bar)
- Loosen clamp screw on the side
- Turn adjusting screw clockwise by using a suitable slotted screwdriver
- Start compressor and check opening pressure, adjust if necessary
- Tighten clamp screw on the side
- Check opening pressure again

Reduce opening pressure:

- Vent filling valve (filling pressure 0 bar)
- Loosen clamp screw on the side
- Turn adjusting screw anti-clockwise by using a suitable slotted screwdriver
- Start compressor and check opening pressure, adjust if necessary
- Tighten clamp screw on the side
- Check opening pressure again



Note

If the adjusted opening pressure of the pressure maintaining valve is higher than the final pressure of the compressor, the final pressure safety valve blows off before pressure maintaining valve opens (final pressure = 0 bar). When valve settings are not clear (e.g. after disassembly / repair), start the adjustment with a low basic setting (turn adjusting bolt 3 full turns in).

MAINTENANCE AND SERVICE

O-rings - filling valve and filling hose

Check o-rings from filling valve and filling hose regularly and change if necessary.



Note

Clean all parts thoroughly before assembly.

O-ring at the filling valve

- Change o-ring, previously grease new o-ring (Fig. 1)

O-ring at the filling hose

- Remove filling hose from the filling valve (Fig. 2)
- Change o-ring, previously grease new o-ring
- Connect filling hose to the filling valve and tighten



Fig. 1 - O-ring at the filling valve



Fig. 2 - O-ring at the filling hose

MAINTENANCE AND SERVICE

A

Test of pressure equipment

According to the Pressure Equipment Directive 2014/68/EU and TÜV Darmstadt (German supervising authorities).

Subject pressure equipment with a product permissible operating pressure [bar] x content volume [litres] from 200 up to max. 1000.

Example: Filter housing 0.69 l

Maximum operating pressure: 350 bar

Content volume: 0.69 litres

$350 \text{ bar} \times 0.69 \text{ litres} = 241.5$

241.5 is bigger than the minimum of 200 -> therefore a test by a licensed expert is required.

1. Examination after 5 years by a qualified person or authorized organisations.

Visual inspection, inside and outside.

2. Examination after 10 years by a qualified person or authorized organisations.

Visual inspection, inside and outside.

In addition, a water pressure test is carried out at 1.5 times of the permissible vessel operating pressure.

The test methods described in point 1 and 2 must be repeated periodically - as described above.

Max. numbers of load cycles for operation with max. allowable pressure variation		
Final pressure [bar]	Load cycles	Operating hours [h]
350	35.000	8.750



Caution

The filter container has to be replaced after 15 years! (LW 150 E MC: 002474 / LW 200 / 250 E MC: 011281)



A

MAINTENANCE RECORDS



STORAGE

Conservation / storage of the compressor

If the compressor unit is not to be used for an extended period of time, we recommend to carry out the following work before storage time:

- Run the compressor at 200 bar filling pressure for approximately ten minutes (control the flow with the filling valve to maintain constant pressure).
- Replace compressor oil, open filling valve(s) and run compressor for a few minutes.
- Stop compressor and open drain valves (depending on the compressor type, this may happen automatically).
- Remove top cap of final filter housing: clean thread, grease o-ring and thread with a food grade grease or silicone grease. Close filter housing.
- Remove intake filter cartridge and undo intake pipes on all valve heads.
- Start compressor unit.
- Spray a few drops of compressor oil into intake connectors.
- Stop compressor unit and insert intake filter cartridge.
- Bring intake pipes back in position and fix connections and nuts. Close filling- and drain valves.
- Store the compressor in a cool dry place free from dust and contamination. A dust cover is recommended as long as condensation can be avoided.
- If compressor unit should be stored for a period of more than one year, an oil change is strongly recommended before it's been re-used.
- Fuel driven units only: fill up fuel tank to top level to avoid corrosion.

A



STORAGE

De-conservation, commissioning

After the compressor has been stored, the following steps are to be taken:

- If compressor hasn't been used for longer than 12 months, we strongly recommend an oil change before any use.
- Replace intake filter cartridge and check oil level.
- Clean compressor unit, check for foreign objects.
- Check condition and tension of V-belts, replace if necessary.
- Check condition of filling hoses, replace if necessary.
- Secure hoses against whipping and open filling valves and run compressor for approximately 10 minutes.
- Check condition of final filter cartridge, replace if necessary.
- Close filling valves and run compressor up to final pressure.
- Check safety valve relief pressure of final stage and/or pressure switch setting.
- Check all connections and pipe work for leaks.
- Once all above steps are completed, compressor unit is now ready for use.

A

STORAGE

Transportation instructions

- Parts which need to be dismantled for transport purposes must be carefully replaced and secured before taking into operation.
- The transport may only be carried out by trained personnel.
- For transportation, only use lifting devices and equipment with sufficient lifting power.
- Do not stand or work under suspended loads.
- Also separate from minor relocation machinery / system of any external energy supply. Before recommissioning, reconnect the machine to the mains according to regulations.
- When recommissioning, proceed according to the operating instructions..

Disposal

The product must be disposed in accordance with national waste disposal regulations and by an appropriate waste disposal company.

Electric and electronic components

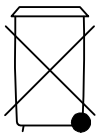

EU-wide regulations for the disposal of electric and electronic appliances which have been defined in the EU Directive 2002/96/EC and in national laws are effective from August 2005 and apply to this device.

Common household appliances can be disposed by using special collecting and recycling facilities. However, as this device has not been registered for household usage, it must not be disposed of through these means.

The device can be returned to L&W. Please do not hesitate to contact us if you have any further questions on this issue.



**ERSATZTEILLISTEN / SPARE PARTS LISTS
DETAILANSICHTEN / DETAILED VIEWS**

C



Inhaltsverzeichnis

Gesamtansicht Kompressor - Overall View Compressor	1
Grundgestell - Main Frame.....	2
Motor - Engine	4
Lüfterabdeckung - Fan Guard	6
Rohrleitungssystem - Pipework.....	7
Füllventil - Filling Valve	9
Endfiltergehäuse - Final Filter Tower.....	11
Gesamtansicht Verdichtereinheit - Overall View Compressor Assembly.....	15
Kompressorblock - Compressor Block	16
Ansaugfilter - Intake Filter.....	19
Öl- Wasserabscheider - Oil- Water Separator	20
Kolben 1. Stufe - Piston 1st Stage	22
Kompressionskolben 2. Stufe - Compression Piston 2nd Stage.....	23
Kompressionskolben 3. Stufe - Compression Piston 3rd Stage.....	24
Saug & Druckventil 2. Stufe - In & Outlet Valve 2nd Stage	25
Saug & Druckventil 3. Stufe - In & Outlet Valve 3rd Stage.....	26
Kurbeltrieb - Crank Drive.....	27
Lagerdeckel schwungradseitig - Bearing Cover Flywheel Side.....	29
Kühler - Cooler	30
Lüfterrad - Flywheel Assembly	32

DETAILANSICHT / DETAILED VIEW

Gesamtansicht Kompressor / Overall View Compressor

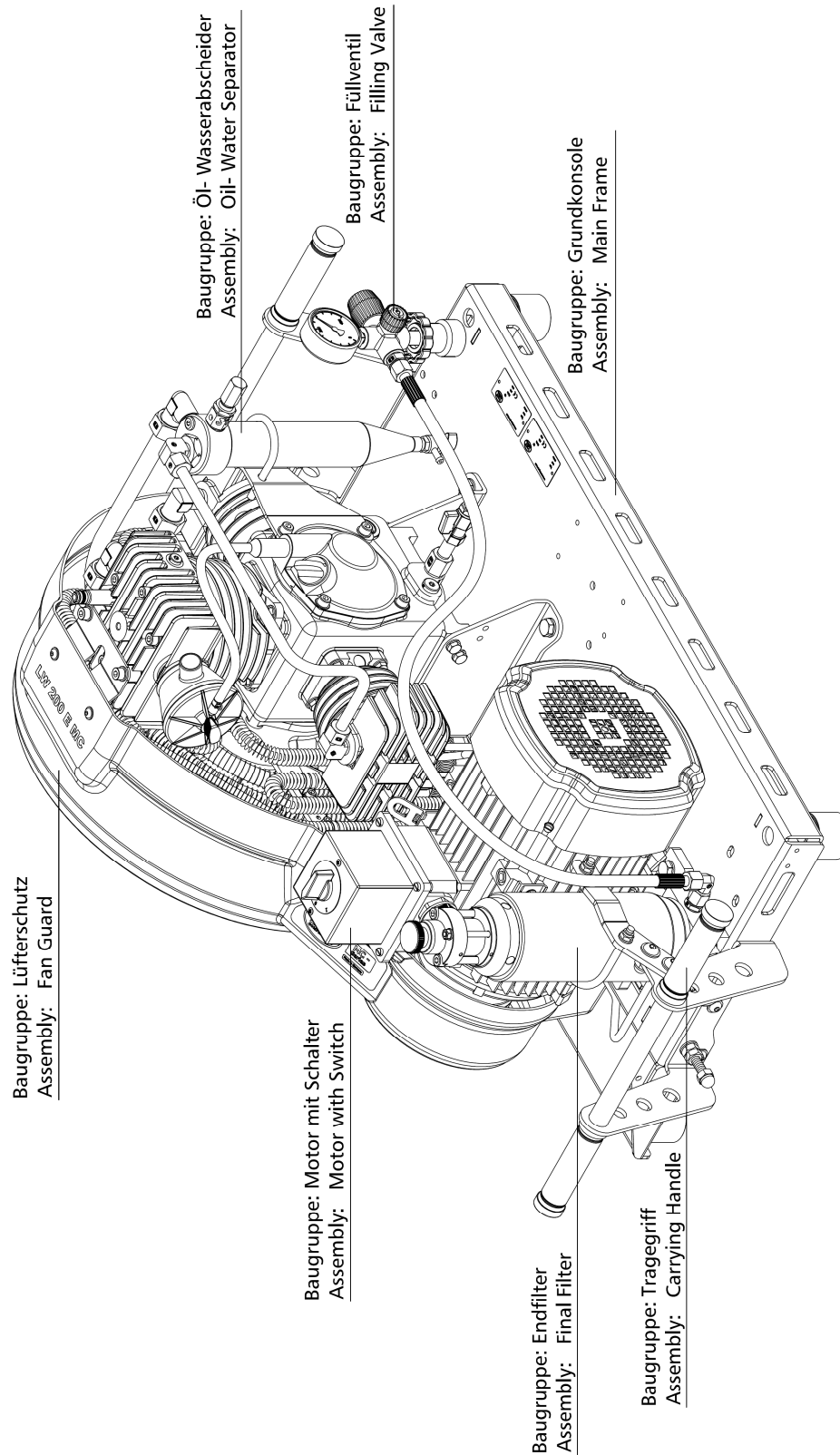

C



ERSATZTEILLISTE / SPARE PART LIST

Baugruppe: Grundgestell / Assembly: Main Frame

Best.-Nr. / Order No.	Benennung	Description
000498	U-Scheibe A6	Washer A6
001159	Stopfmutter	Lock Nut M8
001162	Hutmutter	Domed Nut M10
001181	U-Scheibe A8	Washer A8
001186	U-Scheibe A10	Washer A10
001713	Standfuß, Gummipuffer	Rubber Stand
001859	Befestigungsschraube Antriebsabdeckung	Fixing Bolt V-Belt Cover
008397	Aufsteckstutzen Lüfterabdeckung	Plug-on Fan Cover
008419	Linsenflanschschraube M8x25	Buttonhead Screw M8x25 mm
011002	Grundkonsole	Main Console LW 200
011003	Tragegriff ohne Stütze	Carrying Handle LW 200
011129	Tragegriff mit Stütze	Carrying Handle LW 200
011130	Gummigriffe mit Endkappen (1 Paar)	Rubber grips with end caps
011288	Halter Endfiltergehäuse	Holder Final Filter
011363	Zylinderschraube	Allen Bolt
011364	Linsenschraube	Oval-Head Screw

C

DETAILANSICHT / DETAILED VIEW

Baugruppe: Grundgestell / Assembly: Main Frame

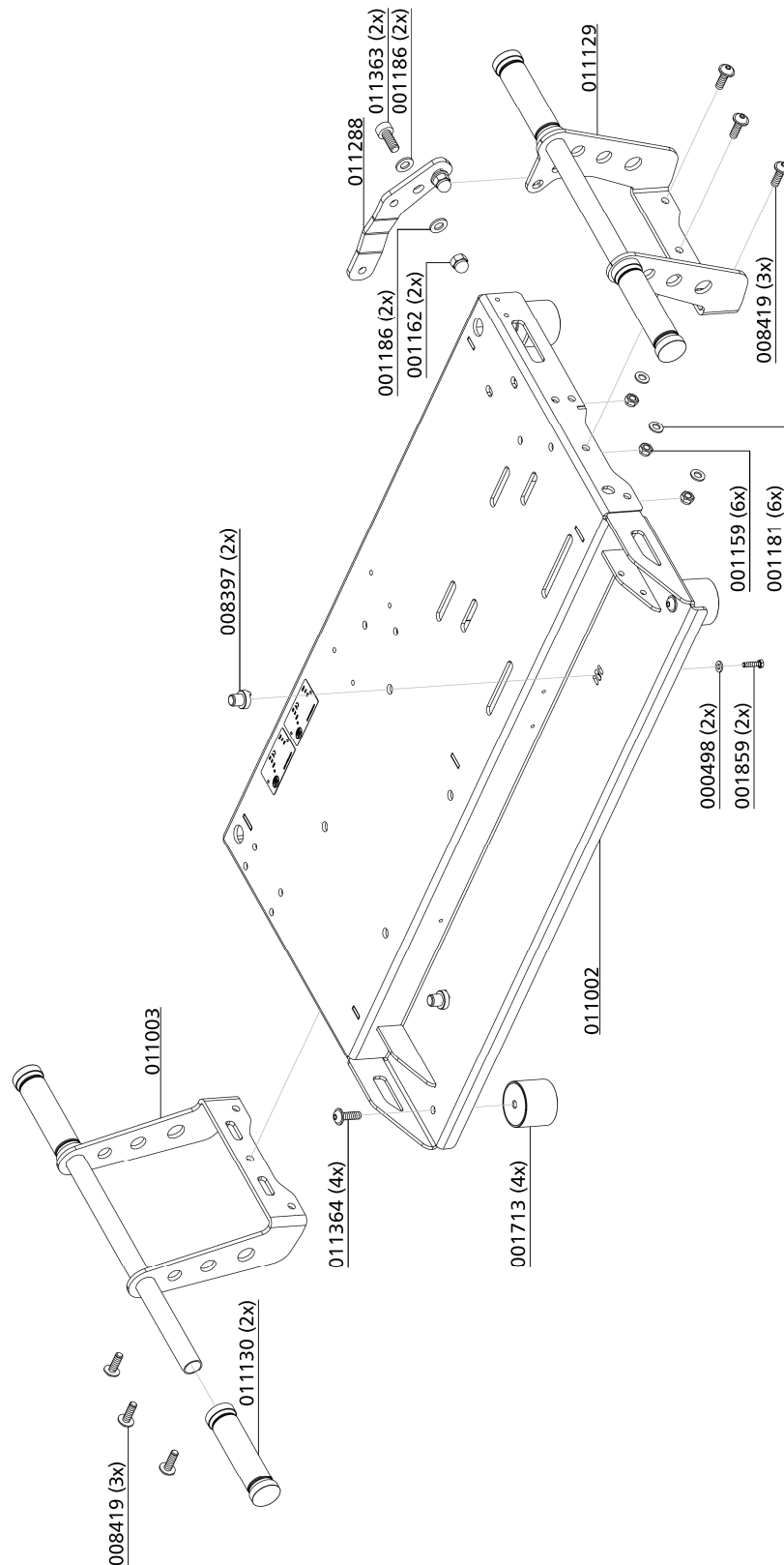



ERSATZTEILLISTE / SPARE PART LIST

Baugruppe: Motor / Assembly: Engine

Best.-Nr. / Order No.	Benennung	Description
000111	Keilriemen SPA 1332	V-Belt SPA 1332
001101	6-kant Schraube M10x35	Hexagon Screw
001105	6-kant Schraube M10x60	Hexagon Bolt
001162	Hutmutter M10	Domed Nut
001163	Mutter M10	Nut
001164	Stoppmutter M10	Lock Nut
001186	U-Scheibe A10	Washer
001828	U-Scheibe A10,5	Washer
003694	Keilriemen SPA 1307	V-Belt SPA 1307
005009	Antriebsmotor 5,5 kW, 230/400V, 50Hz/60Hz	Drive Motor 5.5 kW
007430	Wendeschalter 3-polig W1	Start / Phase Switch
008364	Keilriemenscheibe SPA 160-1	V-Belt Pulley
008644	Spannbuchse Ø28mm	Clamp sleeve for pulley
008798	Antriebsmotor 4,0 kW, 2-polig, 230V / 400V / 50Hz	Drive Motor 4.0 kW
011135	Spannschraube M10	Fixing Block Tensioning Bolt
011153	Antriebsmotor 3,5 kW, 2-polig, 230/400V, 50/60Hz	Drive Motor 3.5 kW
011154	Keilriemen SPA 1382	V-Belt SPA 1382
011155	Keilriemenscheibe SPA 125-1	V-Belt Pulley SPA 125-1
011300	Antriebsmotor 3,0 kW, 1-Phase	Drive Motor 3.0 kW
011373	Keilriemenscheibe SPA 106-1	V-Belt Pulley SPA 106-1
011529	Keilriemenscheibe SPA 132-1	V-Belt Pulley SPA 132-1

DETAILANSICHT / DETAILED VIEW

Baugruppe: Motor / Assembly: Engine

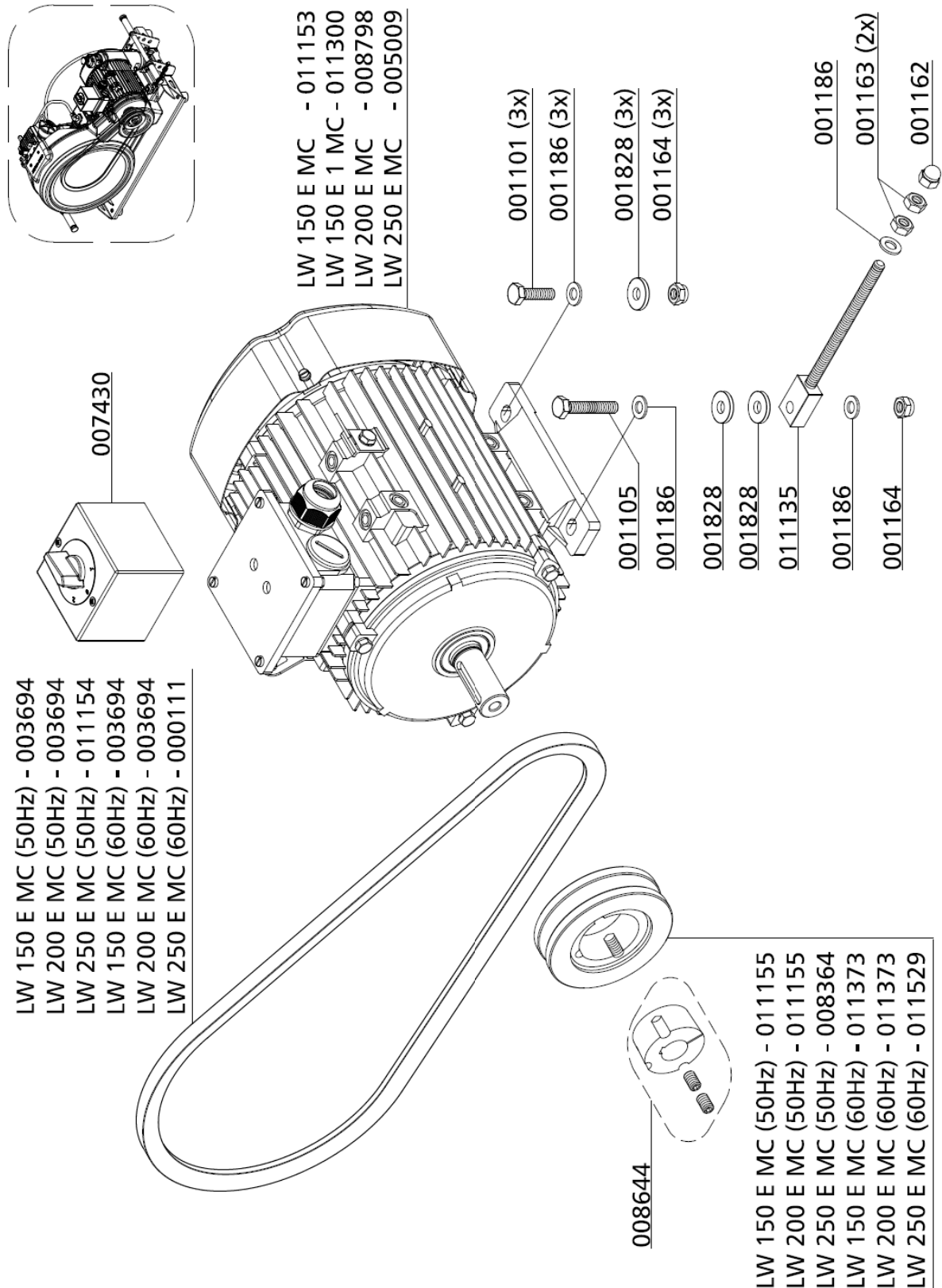

ERSATZTEILLISTE / SPARE PART LIST

Baugruppe: Lüfterabdeckung / Assembly: Fan Guard

Best.-Nr. / Order No.	Benennung	Description
001178	U-Scheibe A6 DIN9021	Washer A6
005839	Linsenflanschschraube M6x25 mm	Flange Button Head Screw
008015	Aufkleber Rotation	Sticker Rotation LW 250 E
008396	Gummitülle, Ventilatorschutz	Rubber Grommet
011131	Ventilatorschutz mit Wellengitter	Fan Guard
011149	Aufkleber "LW 150 E MC"	Sticker "LW 150 E MC", white
011150	Aufkleber "LW 200 E MC"	Sticker "LW 200 E MC", white
011151	Aufkleber "LW 250 E MC"	Sticker "LW 250 E MC", white
011152	Aufkleber "LW MC-Series"	Sticker "LW MC-Series", w/b
011358	Gummitülle Ø18x24x7 mm	Rubber Grommet
011504	Haltebolzen Ventilatorschutz oben	Support Bolt - Fan Cover

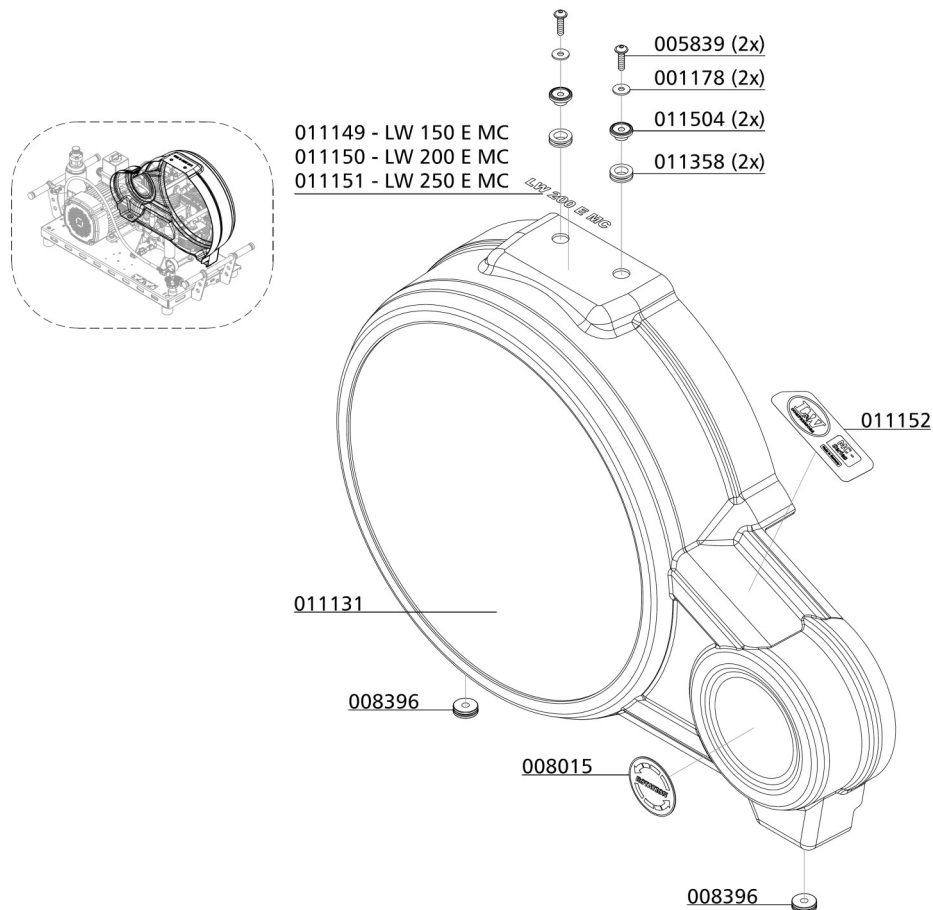



ERSATZTEILLISTE / SPARE PART LIST

Rohrleitungssystem / Pipework

Best.-Nr. / Order No.	Benennung	Description
000498	U-Scheibe A6	Washer A6
000797	Verschraubung	Elbow Connection
001176	U-Scheibe A5	Washer A5
001859	Sechskant Ø5,5x19	Fixing Bolt
002811	Hochdruckschlauch	HP-Hose
006254	Füllventilhalter	Filling Valve Holder
008656	Rohrschelle Ø8mm / 12 mm breit	P-Clip
009760	Zylinderschraube M5x12mm	Allen Screw
011156	Rohrleitung Ø8mm, komplett mit M.&S.	Pipe Ø8mm, c/w Nut and Olive
011157	Rohrleitung Ø12mm, komplett mit M.&S.	Pipe Ø12mm, c/w Nut and Olive

C

DETAILANSICHT / DETAILED VIEW

Rohrleitungssystem / Pipework

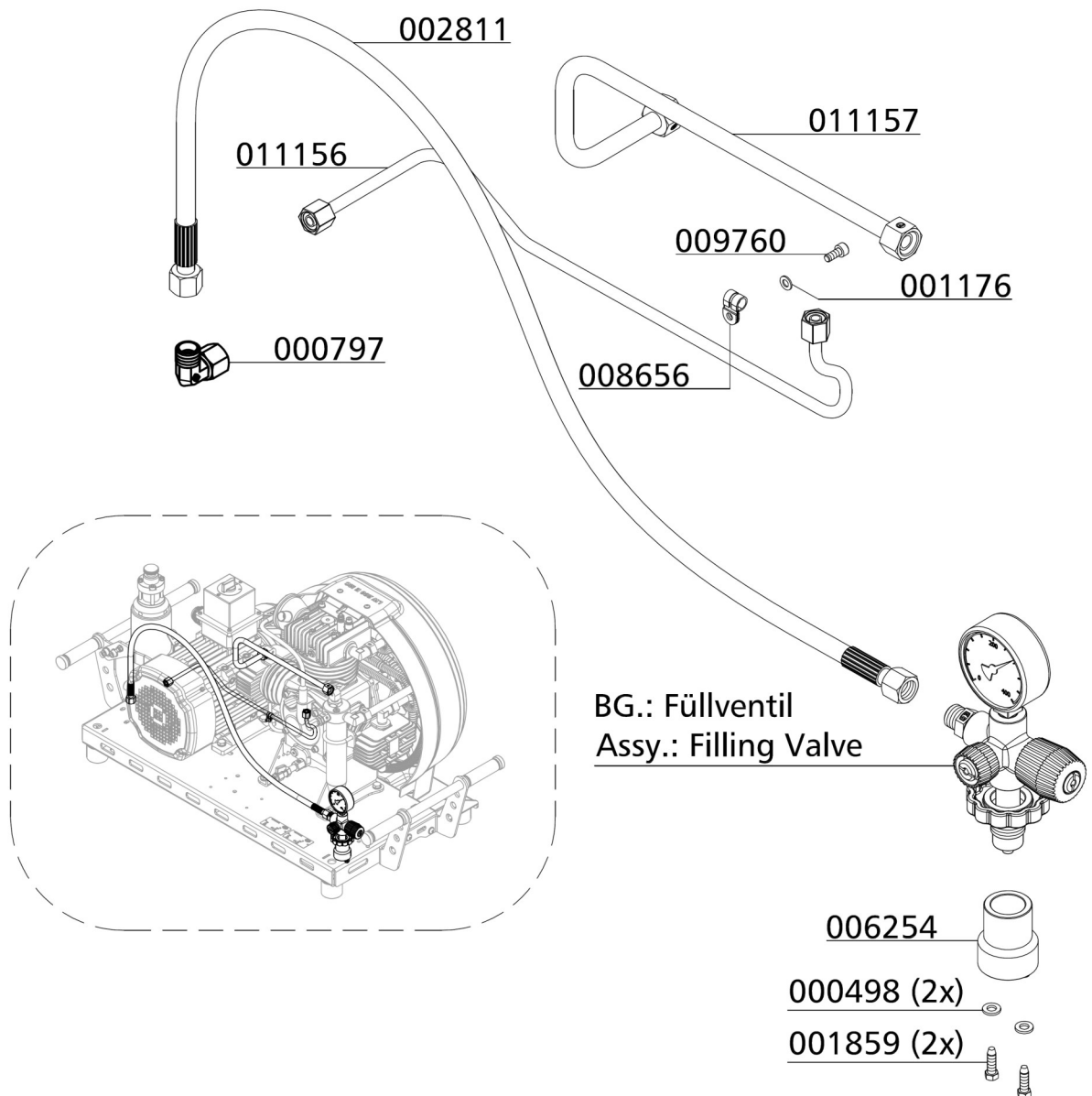



ERSATZTEILLISTE / SPARE PART LIST

Baugruppe: Kreuzventil / Assembly: Cross Design Valve

Best.-Nr. / Order No.	Benennung	Description
000213	Handrad, schwarz DIN 200bar	Hand Wheel DIN 200 bar, black
000215	Handrad rot DIN 300bar	Hand Wheel DIN 300 bar, red
000386	Gleitscheibe, Kreuzventil	Slide Washer
000387	Feder (Kreuzventil)	Coil Spring, cross d. valve
000665	Manometer, (Messing)	Pressure Gauge, (brass)
000666	Manometerschutzkappe Ø63mm	Protector Pressure Gauge Ø63mm
000696	Füllanschluss o. Handrad 200bar	Filling Connector w/o handwheel 200bar
000698	Füllanschluss o. Handrad 300bar	Filling Connector w/o handwheel 300bar
000709	Füllventil Kreuzbauweise, kompl.	Filling Valve cross design
001237	O-Ring DIN Flaschenanschluss	O-Ring DIN filling connector
001391	O-Ring	O-Ring
001392	Füllhandrad Kreuzventil	Hand Wheel Filling Valve cross
001393	Entlüftungsspindel	Vent Spindle
001394	Entlüftungshandrad	Vent Hand Wheel
001395	Gleitscheibe, schwarz, Kreuzventil	Slide Washer, plastic black
001397	Kupferdichtung	Copper Seal Ring
001398	Madenschraube	Worm Screw
001399	Oberspindel	Adapter Shaft
001400	Dichtspindel, Kreuzventil	Seal Spindle Filling Valve
001401	Schlitzmutter	Slotted Nut
001402	Gehäuseverschraubung komplett mit O-Ringen	Filling Spindle Body c/w O-Rings
002812	Verschraubung, Edelstahl	Connection, S/S
003687	Füllventil Kreuzbauweise komplett 200bar	Filling Valve cross complete unit 200bar
003688	Füllventil Kreuzbauweise komplett 300bar	Filling Valve cross complete unit 300bar
004977	Manometer, (Edelstahl)	Pressure Gauge, (s/s)

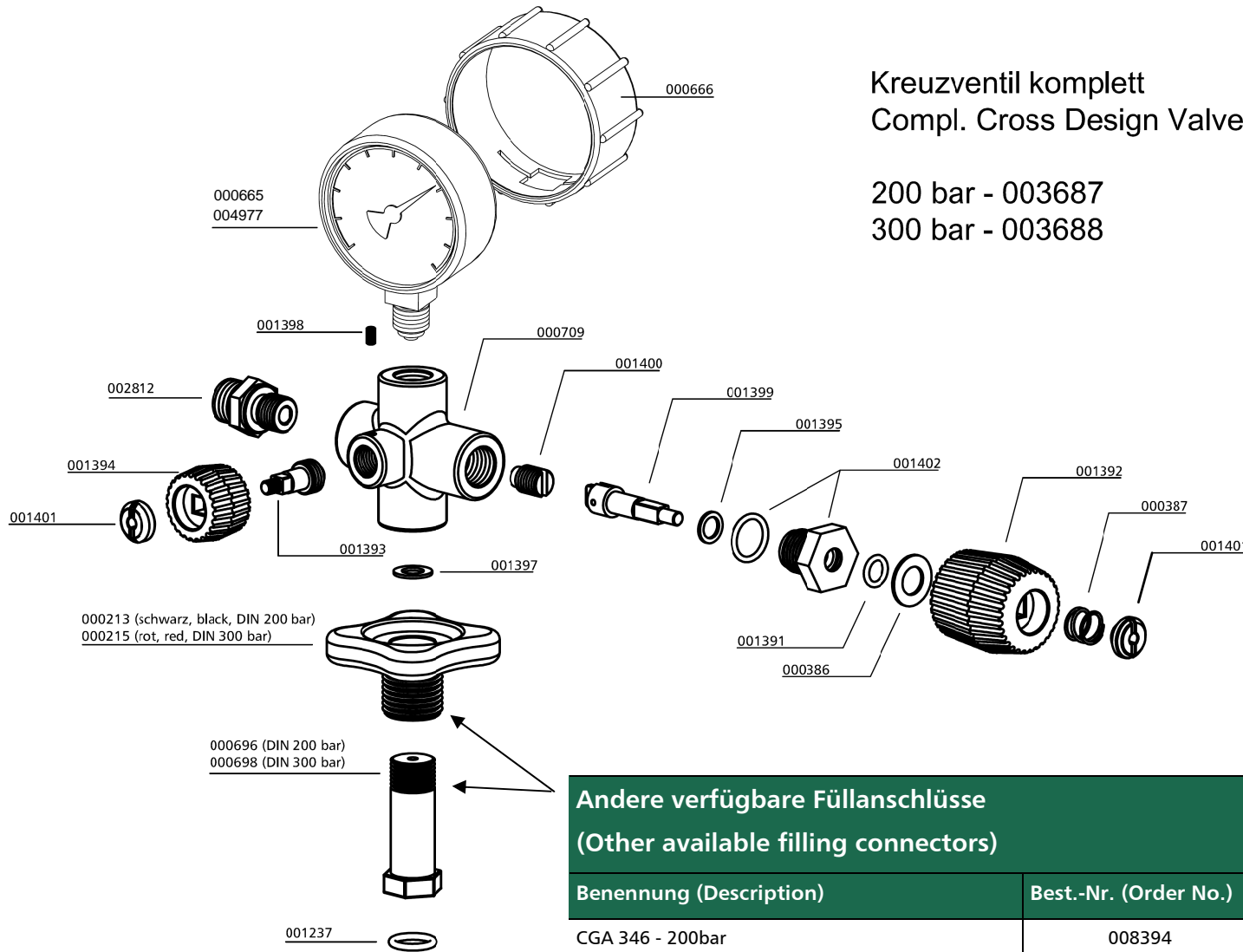

Kreuzventil komplett
Compl. Cross Design Valve

200 bar - 003687
300 bar - 003688

**Andere verfügbare Füllanschlüsse
(Other available filling connectors)**

Benennung (Description)	Best.-Nr. (Order No.)
CGA 346 - 200bar	008394
CGA 347 - 300bar	006842
INT / Yoke - 200/232 bar	002307

DETAILANSICHT / DETAILED VIEW

Baugruppe: Kreuzventil / Assembly: Cross Design Valve





ERSATZTEILLISTE / SPARE PART LIST

Baugruppe: Endfiltergehäuse (0,46 Ltr. / 0,69 Ltr.) /

Assembly: Final Filter Tower (0,46 l. / 0,69 l.)

Best.-Nr. / Order No.	Benennung	Description
000506	Druckfeder	Spring
000508	USIT Ring	Gasket Ring U-Sit
000516	Nutring, DHRV	Seal Ring PMV
000517	Druckfeder, DHRV	Coil Spring PMV
000518	U-Scheibe	Washer, M5, brass
000519	Dichtkappe, DHRV	Plastic Seal Piston PMV
000644	Filterpatrone	BA Filter Cartridge
000738	Gerade Verschraubung	Straight Connection
000783	Gerade Verschraubung	Straight Connection
000837	Verschlussstopfen	Plug
000941	Madenschraube	Worm Screw
001039	Zylinderschraube	Allen Bolt
001159	Stopfmutter M8	Lock Nut M8
001181	U-Scheibe A8	Washer A8
001718	Innenrohr Filtergehäuse	Inner Tube Filter Housing
001742	Druckstift , DHRV	Pressure Pin
001743	Einlassverschraubung, DHRV	Inlet Connection
001744	Einstellschraube, DHRV	Adjusting Bolt
001745	Düsenrohr, HD-Filter	Inlet Jet
001753	Patronenstift, Zylinder	Cartridge Pin
001769	O-Ring, Filtergehäuse	O-Ring Filter Housing LW 100
001788	Federdruckstück	Spring Adapter
001795	Filterschlüssel	Filter Tool
001819	O-Ring, Filterpatrone-Nippel	O-Ring, Filter cartrid. nipple
001825	O-Ring, Filterpatrone	O-Ring, filter cartridge
002309	Filterpatrone	Filter cartridge
002474	Filtergehäuse kompl. mit DHRV, Schlüssel	Filter housing c/w PMNRV

C



ERSATZTEILLISTE / SPARE PART LIST

Baugruppe: Endfiltergehäuse (0,46 Ltr. / 0,69 Ltr.) /

Assembly: Final Filter Tower (0,46 l. / 0,69 l.)

Best.-Nr. / Order No.	Benennung	Description
003006	O-Ring, DHV	O-Ring, PMV
003077	Entwässerungsventil R1/4 AG, konisch	Drain Valve R1/4 male
008347	Schraubadapter	Screw Adapter
008348	Düsenrohr Hochdruckfilter	Nozzle Tube
009657	Filterschlüssel	Filter key
010572	Drallscheibe	Swirl Disk
010573	Umlenkung Einlassluftstrom	Deflection Inlet Airflow
010576	O-Ring	O-ring 63,5 x 2
010759	Zylinderschrauben M4x12mm	Allen Bolt M4x12mm
011174	Atemluft Filterpatrone 0,69 Liter	Filter Cartridge 0.69 ltr.
011189	Filterpatrone 0,69 Liter	Filter Cartridge 0,69 ltr.
011281	Filtergehäuse 0,69 Liter kompl. mit DHRV	Filter housing c/w PMV 0.69 L
011536	Haltebügel Filtergehäuse	U-Clamp for Filter Housing
012495	Filtergehäuse kompl. mit DHRV, 0,46 Ltr	Filter housing c/w PMNRV 0.46L

Nicht einzeln lieferbar / not available separatly

Best.-Nr. / Order No.	Benennung	Description
001716	Obere Verschlusschraube Filtergehäuse	Plug Filter Housing
001717	Filtersockel, (Filtergehäuse)	Base Filter Housing
001718	Innenrohr Filtergehäuse	Inner Tube Filter Housing
001719	Druckbehälterrohr, Ø100x230mm	Tube Filter Housing Ø100x230mm
011173	Druckbehälterrohr, Ø95x325mm	Tube Filter Housing Ø95x325mm

DETAILANSICHT / DETAILED VIEW

Baugruppe: Endfiltergehäuse (Volumen 0,69 Ltr.)

Assembly: Final Filter Tower (Volume 0.69 ltr.)

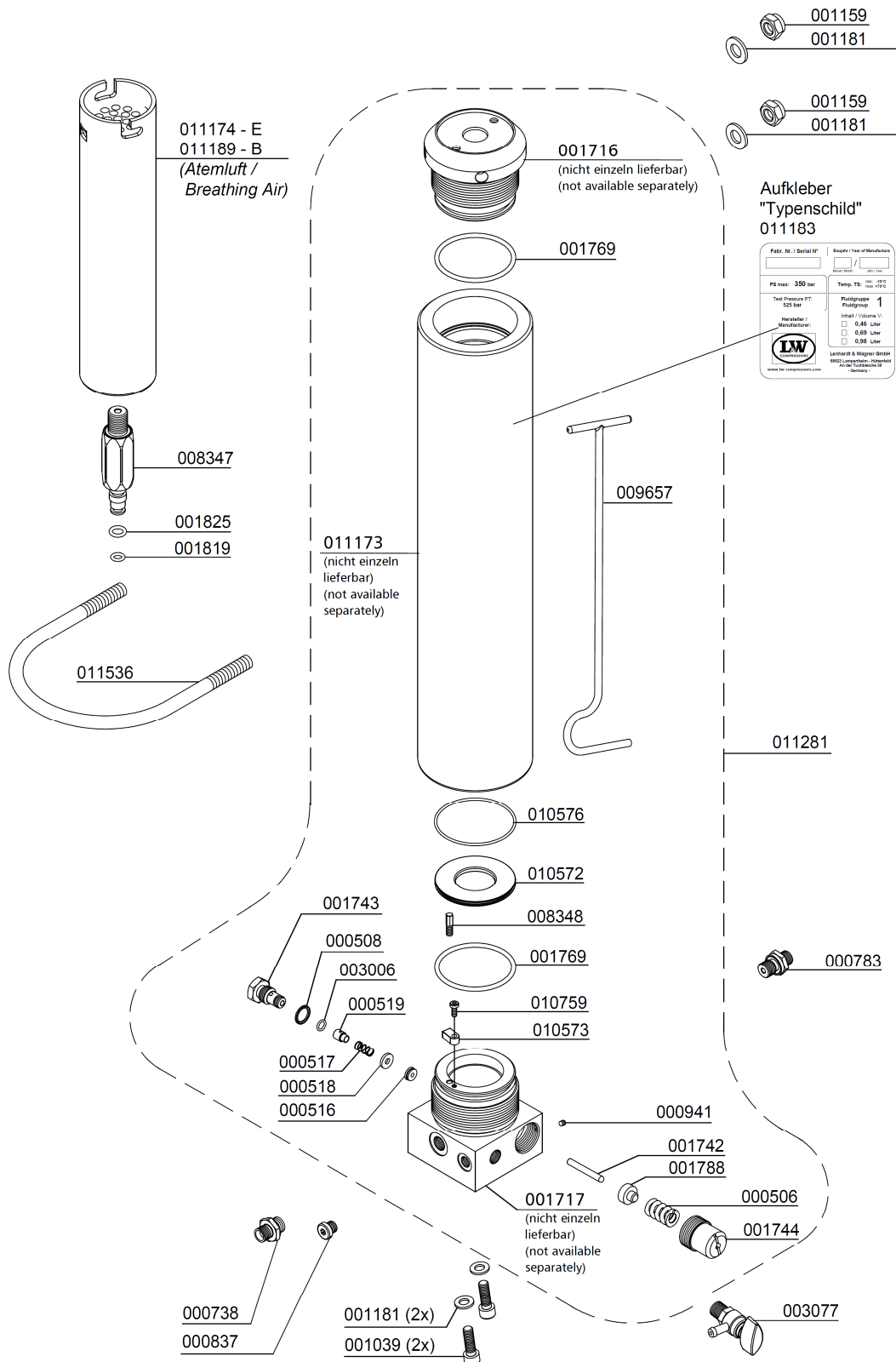

C

DETAILANSICHT / DETAILED VIEW

Gesamtansicht Verdichtereinheit / Overall View Compressor Assembly

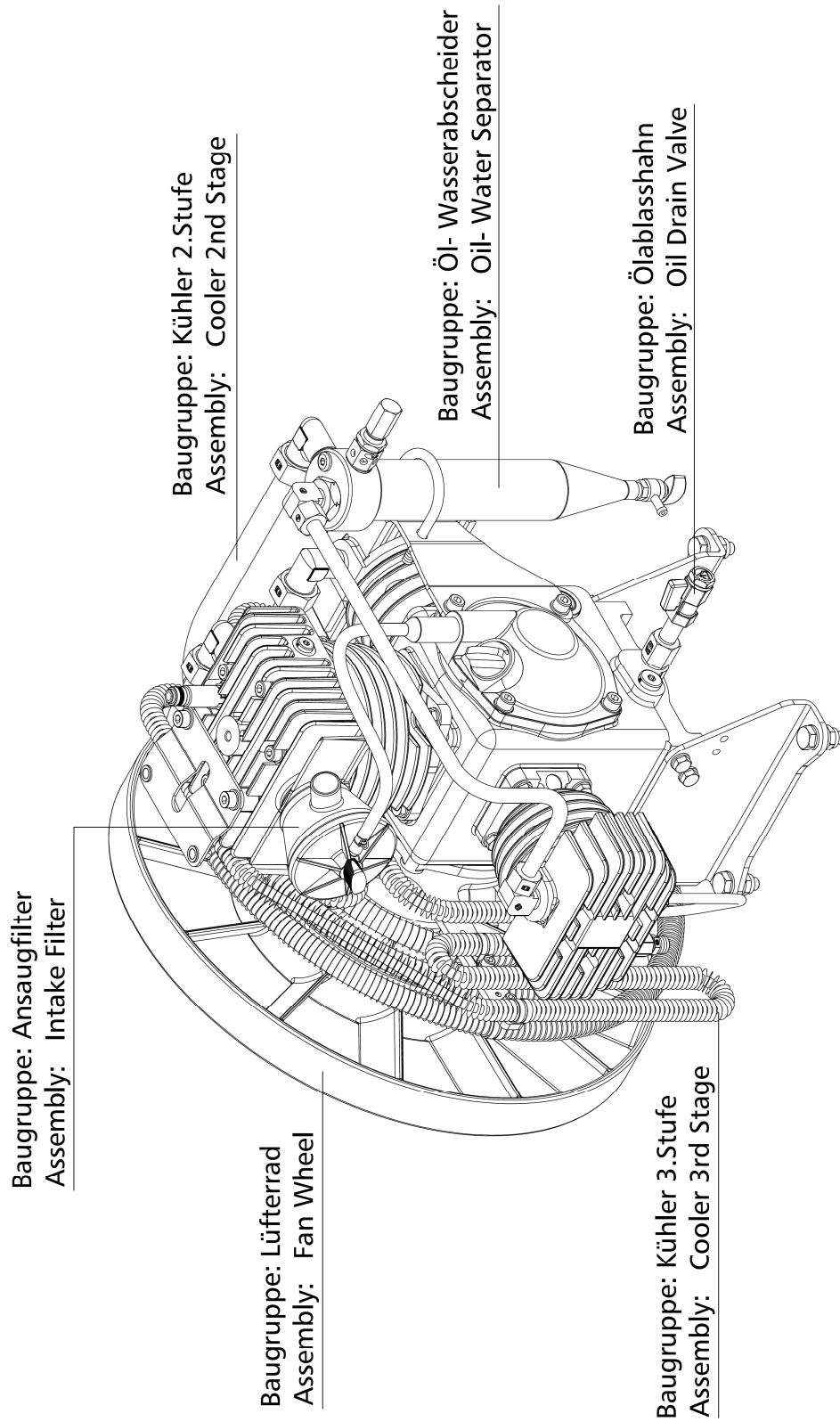



ERSATZTEILLISTE / SPARE PART LIST

Baugruppe: Kompressorblock / Assembly: Compressor Block

Best.-Nr. / Order No.	Benennung	Description
000220	Sicherheitsventil G3/8, 8 bar	Safety Valve
000738	Gerade Verschraubung GE 08 L	Straight Connection
000811	Winkelverschraubung WE 12L G3/8	Elbow Connection
000837	Verschlussstopfen G1/8	Plug
000838	Verschlussstopfen G1/4	Plug
000863	Winkelverschraubung WE 18L R1/2	Elbow Connection
001041	Zylinderschraube M8x25mm	Allen Screw
001042	Zylinderschraube M8x30mm	Allen Screw
001045	Zylinderschraube M8x45mm	Allen Screw
001056	Zylinderschraube M8x60mm	Allen Screw
001060	Zylinderschraube M8x80mm	Allen Screw
001063	Zylinderschraube M8x95mm	Allen Screw
001081	6-kant Schraube M8x20mm	Hexagon Screw
001082	6-kant Schraube M8x25mm	Hexagon Screw
001159	Stopfmutter M8	Lock Nut
001164	Stopfmutter M10	Lock Nut
001181	U-Scheibe A8	Washer
001186	U-Scheibe A10	Washer
002124	Ventilkopf 3. Stufe	Valve Head 3rd Stage
003651	Obere Dichtung Ventil 1.Stufe	Gasket, Valve 1st Stage (up)
003652	Saug- & Druckventil 1. Stufe	Valve 1st stage
003766	Aludichtring für G3/8 Gewinde	Alloy Seal Ring for G3/8
005856	Winkelverschraubung Ø8mm R1/8	Elbow Hose Connection
006846	Schlauchschelle	Hose Clamp
007043	Kondensatschlauch Ø5,4xØ9,4mm	Condensate Hose
008482	Haltebügel für Wasserabweiser	U-Clamp Water Separator
008696	6kt-Schraube M10x30mm	Hexagon Screw
010451	Ventilkopf 1. Stufe	Valve Head 1st Stage
010785	O-Ring Ø128 x 2mm	O-Ring
010810	Zylinder 1.Stufe	Cylinder 1st Stage



ERSATZTEILLISTE / SPARE PART LIST

Baugruppe: Kompressorblock / Assembly: Compressor Block

Best.-Nr. / Order No.	Benennung	Description
010811	Zylinder 1.Stufe	Cylinder 1st Stage
010812	Zylinder 2.Stufe	Cylinder 2nd Stage
010813	Zylinder 3.Stufe	Cylinder 3rd Stage
010819	Lagerdeckel	Bearing Cover
010833	Kugelhahn 2 x G3/8 IG	Ball Valve
010834	Doppelnippel R3/8, Länge 40mm	Double Nipple
011092	Ölschauglas mit Dichtung G3/4	Oil Level Indicator c/w gasket
011103	O-Ring Ø81x2mm	O-ring
011104	O-Ring Ø84x2mm	O-ring
011105	O-Ring Ø50x2mm	O-ring
011106	Anschlussadapter Kurbelgehäuseentlüftung	Adapter Crankcase Vent
011107	Distanzstück 15mm	Spacer 15mm
011109	Verschlussschraube GN 740 G3/8	Plug
011110	Verschlussschraube GN 441 G3/4	Plug
011111	Luftleitblech mit Gewindenieten	Air Deflector
011112	Halteblech Wasserabscheider	Holder Oil- Water Separator
011113	Halteblech Kühler	Holder Cooler
011115	Konsole Kompressorblock	Console Compressor Block
011280	Ventilkopf 2. Stufe	Valve Head 2nd Stage

ERSATZTEILLISTE / SPARE PART LIST

Baugruppe: Ansaugfilter / Assembly: Intake Filter

Best.-Nr. / Order No.	Benennung	Description
001707	Ansaugfiltergehäuse	Air Intake Filter Housing
001708	Ansaugfilterpatrone	Air Intake Filter Cartridge
001772	Flügelmutter PVC-schwarz	Winged Nut, PVC black
001778	O-Ring Ø22x2mm	O-Ring
001782	O-Ring Ø80x2mm	O-Ring
001829	Deckel Ansaugfiltergehäuse	Cover Air Intake Housing

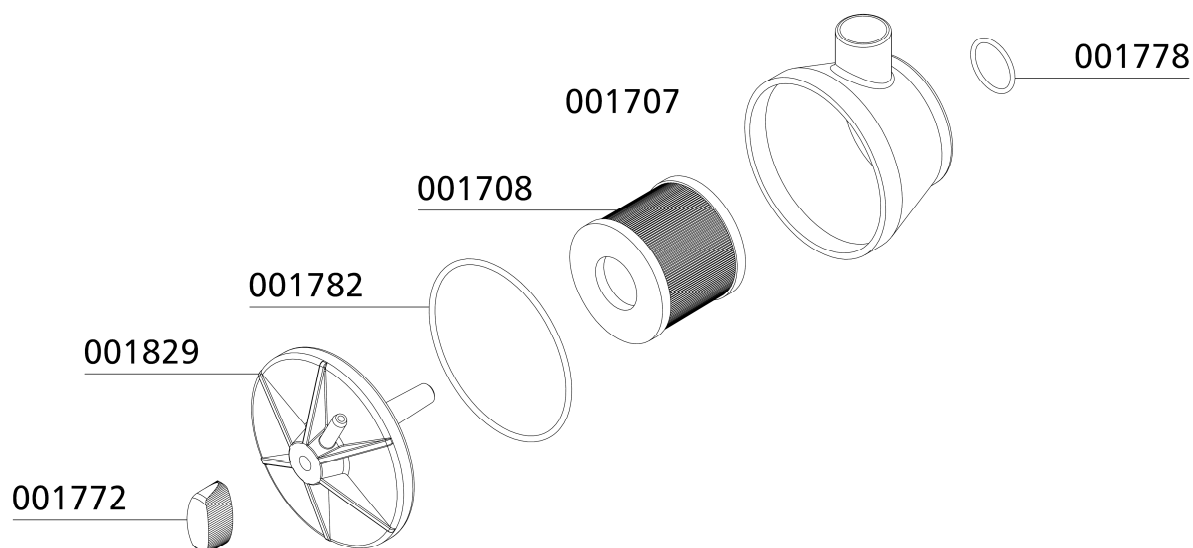



ERSATZTEILLISTE / SPARE PART LIST

Baugruppe: Öl- Wasserabscheider / Assembly: Oil- Water Separator

Best.-Nr. / Order No.	Benennung	Description
000227	Sicherheitsventil G3/8" 70bar	Safety Valve G3/8" 70bar
000811	Winkelverschraubung WE 12L R3/8	Elbow Connection
000837	Verschlussstopfen G1/8	Plug
000863	Winkelverschraubung WE 18L R1/2	Elbow Connection
001255	O-Ring Ø26x2mm	O-Ring
002123	Sinterfilter G3/8 AG	Sinter Filter
002128	Wasserabscheider, 1. und 2. Stufe	Water separa. 1st + 2nd Stage
002130	Halter für Sinterfilter G3/8	Holder for Sinterfilter G3/8
003077	Entwässerungsventil R1/4 AG, konisch	Drain Valve R1/4 male
003766	Aludichtring für G3/8 Gewinde	Alloy Seal Ring

C

DETAILANSICHT / DETAILED VIEW

Baugruppe: Öl- Wasserabscheider / Assembly: Oil- Water Separator

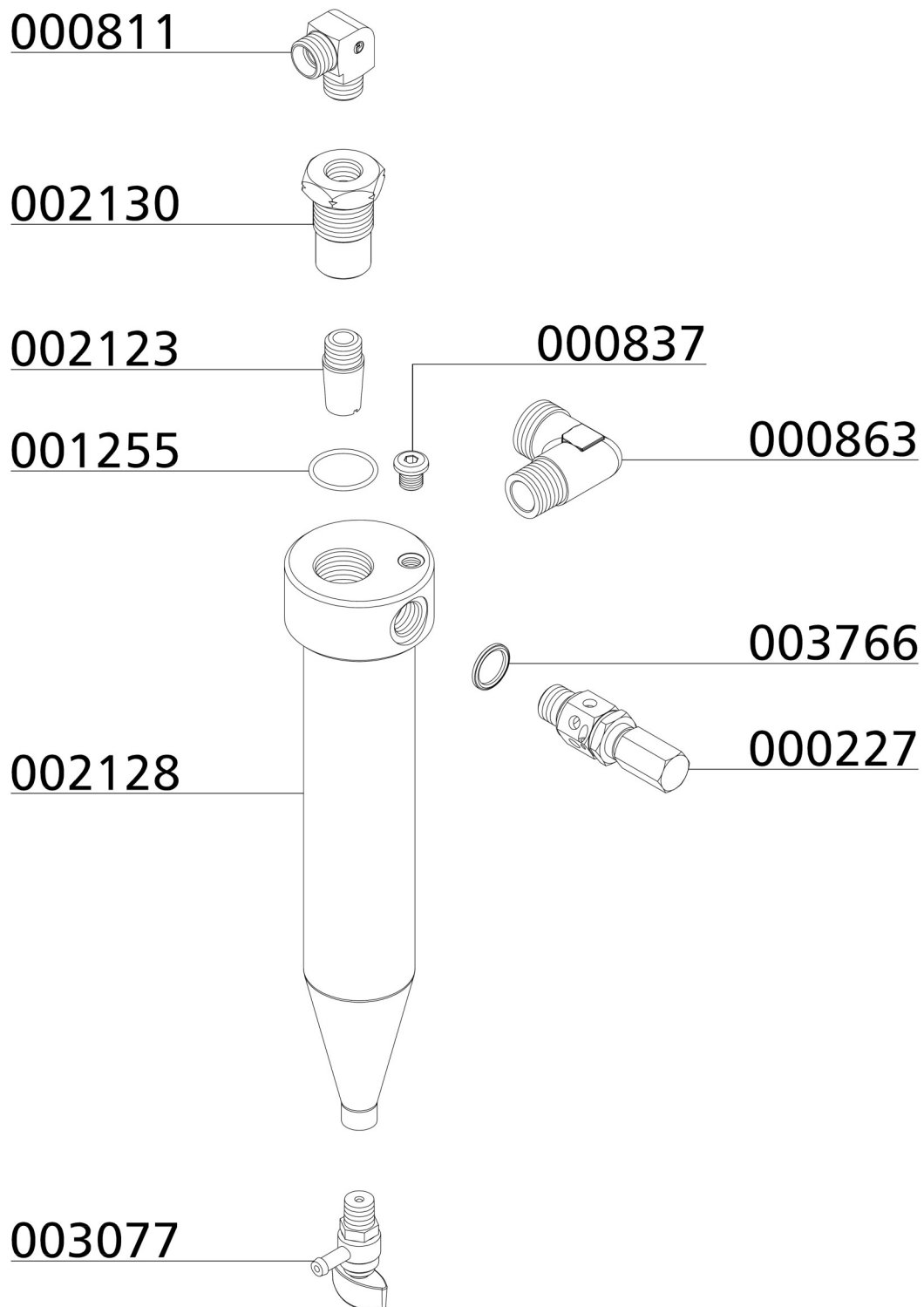

C

Baugruppe: Kolben 1. Stufe / Assembly: Piston 1st Stage

Best.-Nr. / Order No.	Benennung	Description
000047	Satz Kolbenringe Ø75,5mm 1. Stufe	Set Piston Rings 1st Stage
000051	Satz Kolbenringe Ø72mm 1. Stufe	Set Piston Rings 1st Stage
010814	Kolben 1.Stufe Ø75,5mm, komplett	Piston 1st Stage, complete
010815	Kolben 1.Stufe Ø80mm, komplett	Piston 1st Stage, complete
011116	Satz Kolbenringe Ø80mm 1. Stufe	Set Piston Rings 1st Stage
011602	Kolben 1.Stufe Ø72mm, komplett	Piston 1st Stage, complete

C

011602 - LW 150 MC
 010814 - LW 200 MC
 010815 - LW 250 MC

000051 - LW 150 MC
 000047 - LW 200 MC
 011116 - LW 250 MC

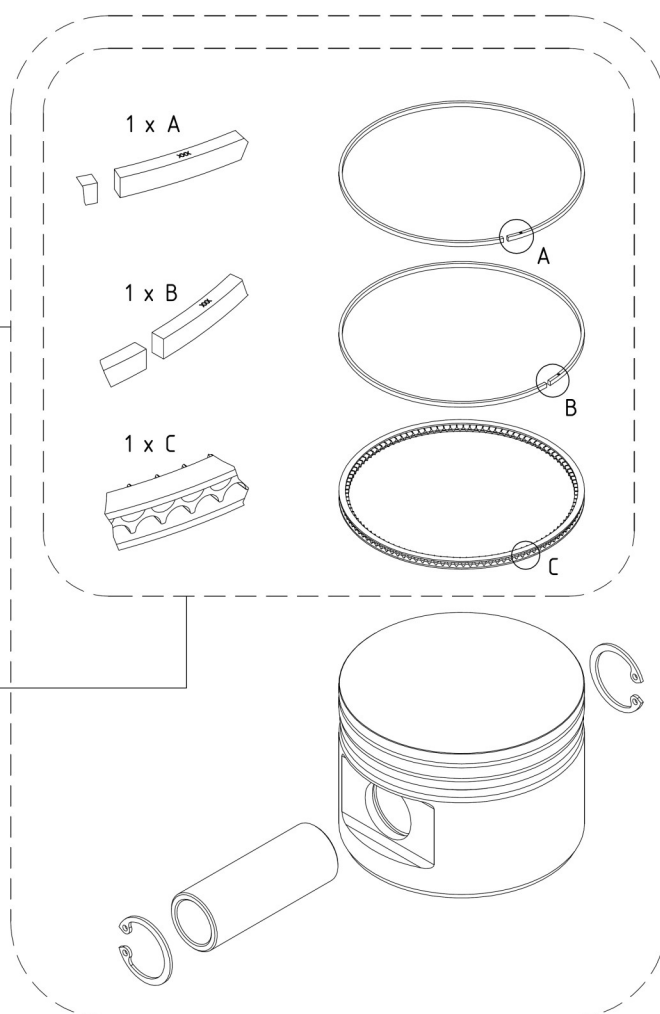

ERSATZTEILLISTE / SPARE PART LIST

Baugruppe: Kompressionskolben 2. Stufe

Assembly: Compression Piston 2nd Stage

Best.-Nr. / Order No.	Benennung	Description
010816	Kolben 2.Stufe Ø32mm komplett	Piston 2nd Stage, complete
011117	Satz Kolbenringe 2. Stufe / 7Stk.	Set of Piston Rings, 2nd Stage

010816 - Ø32mm

011117 - Ø32mm

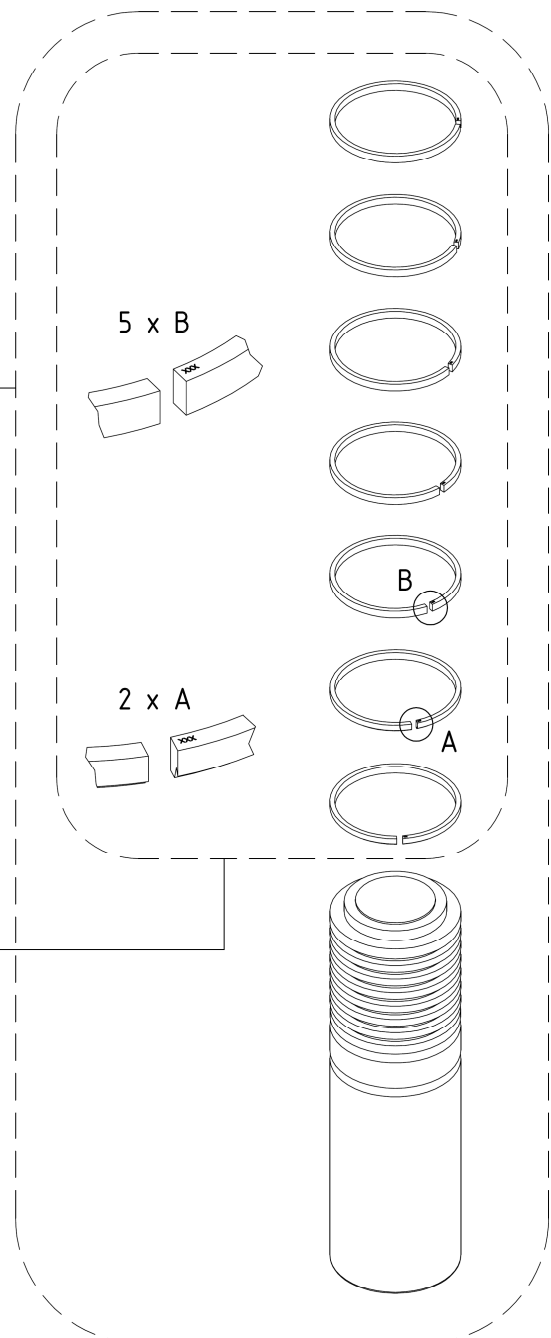

C

ERSATZTEILLISTE / SPARE PART LIST

Baugruppe: Kompressionskolben 3. Stufe
Assembly: Compression Piston 3rd Stage

Best.-Nr. / Order No.	Benennung	Description
010817	Kolben 3.Stufe Ø14mm komplett	Piston 3rd Stage
011118	Satz Kolbenringe 3. Stufe / 7Stk.	Set of Piston Rings, 3rd Stage

C

010817 - Ø14mm

011118 - Ø14mm

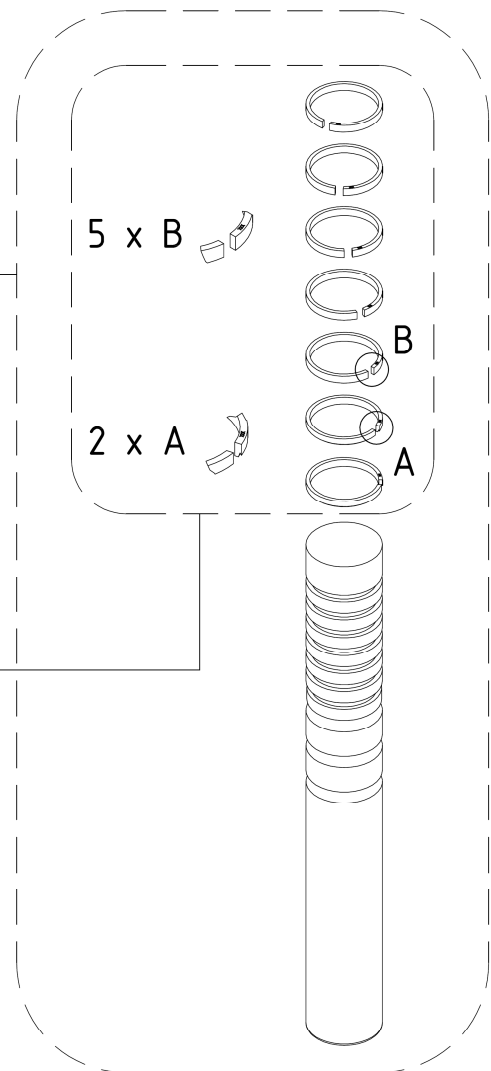

ERSATZTEILLISTE / SPARE PART LIST

Baugruppe: Saug & Druckventil 2. Stufe / Assembly: In & Outlet Valve 2nd Stage

Best.-Nr. / Order No.	Benennung	Description
000532	Ventildichtung, Saug-& Druckventil unten	Lower Valve Gasket
000541	Dichtring / Dichtung Ventil	Upper Alloy Seal Ring
000551	Saug- & Druckventil	In- & Outlet Valve

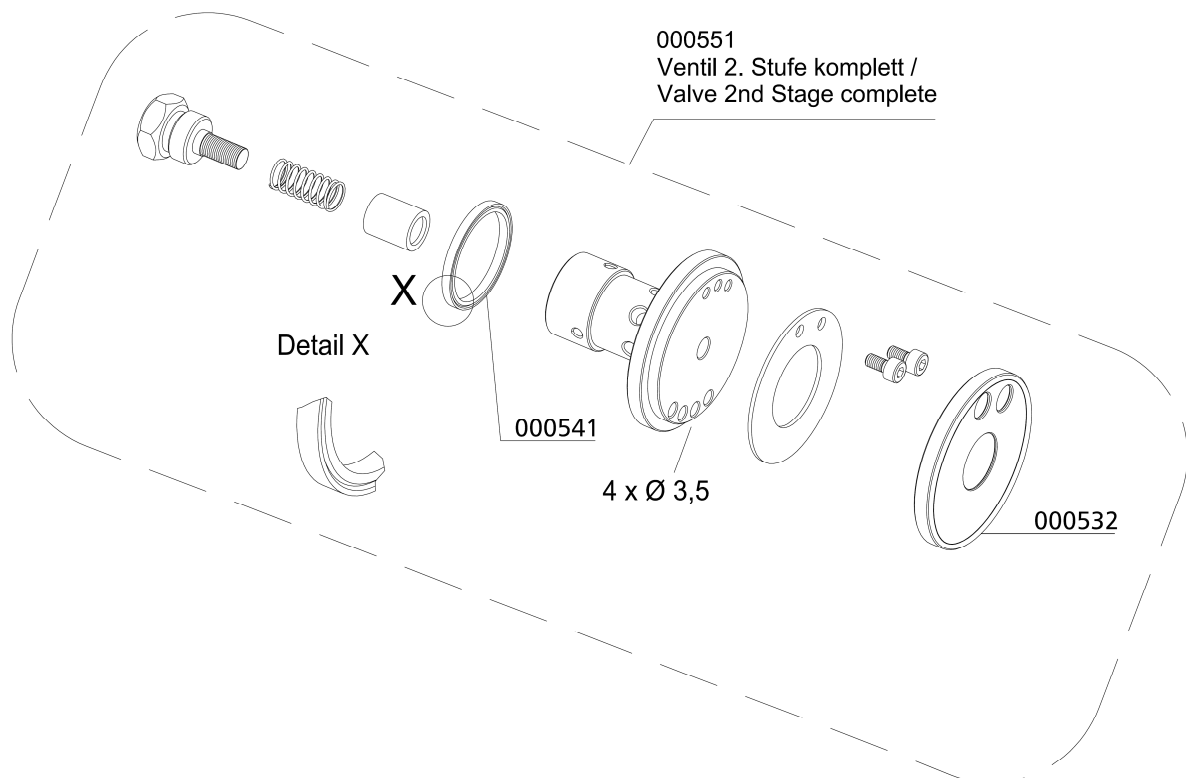

ERSATZTEILLISTE / SPARE PART LIST

Baugruppe: Saug & Druckventil 3. Stufe / Assembly: In & Outlet Valve 3rd Stage

Best.-Nr. / Order No.	Benennung	Description
000534	Ventildichtung, Saug- & Druckventil	Lower Valve Gasket
000541	Dichtring / Dichtung Ventil	Upper Alloy Seal Ring
011123	Saug-Druckventil, komplett	In- & Outlet Valve

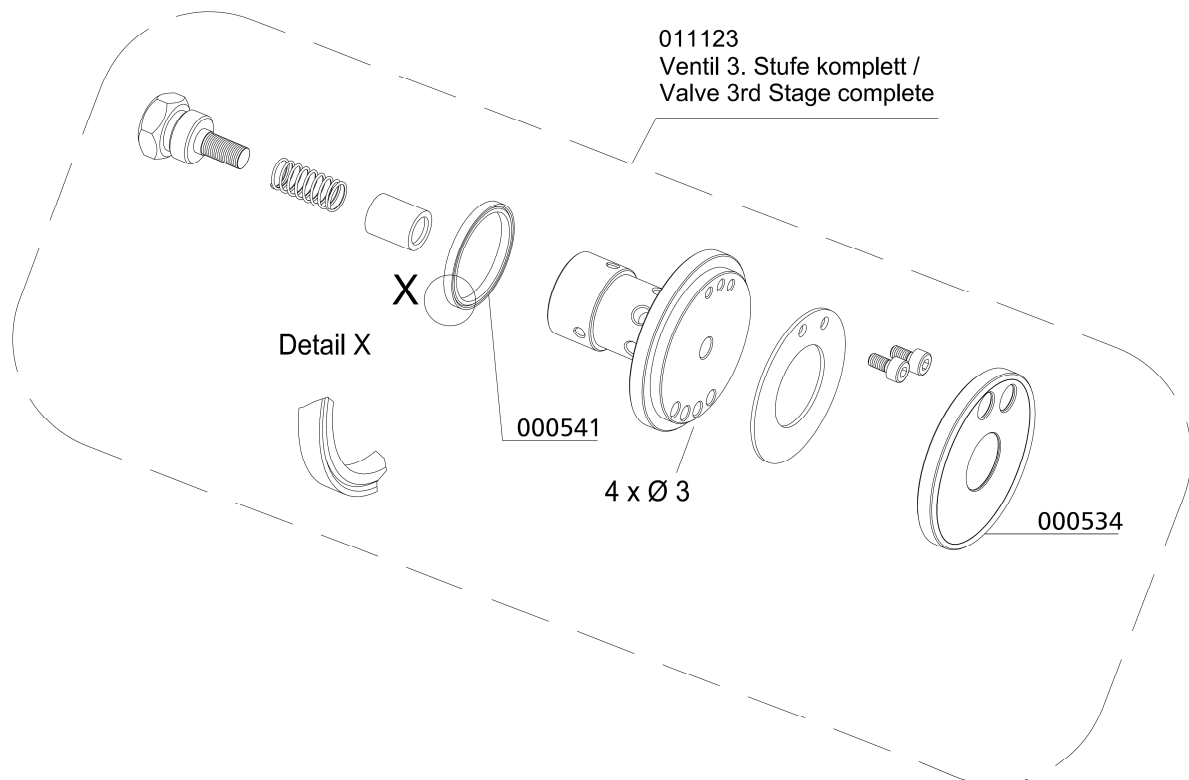



ERSATZTEILLISTE / SPARE PART LIST

Baugruppe: Kurbeltrieb / Assembly: Crank Drive

Best.-Nr. / Order No.	Benennung	Description
000839	Verschlussstopfen	Plug
000969	Zylinderschraube	Allen Bolt
001010	Zylinderschraube	Allen Screw
001323	CU-Ring	Copper Seal Ring
001336	Sicherungsring	Circlip A16
001342	Sicherungsring	Circlip A30
001365	Sicherungsring	Circlip I35
010112	Passfeder	Woodruff Key
010809	Kurbelgehäuse	Crankcase
010818	Pleuel 1.Stufe	Con Rod
010823	Kurbelwelle	Crankshaft
010824	Gegengewicht-Unterteil	Counterweight lower Part
010829	Kreuzkopf	Crosshead
010830	Kreuzkopfbolzen	Crosshead Pin
011099	Flachkopfschraube	Pan Head Bolt
011100	Passfeder	Woodruff Key
011121	Zylinderrollenlager 17x40x16 mm	Bearing
011122	Nadellager 22x34x20 mm	Bearing
011352	Sockel	Base
011353	Kulisse komplett	Motion Link complete

C

DETAILANSICHT / DETAILED VIEW

Baugruppe: Kurbeltrieb / Assembly: Crank Drive

Ab Blocknummer 14
From Block Number 14

C

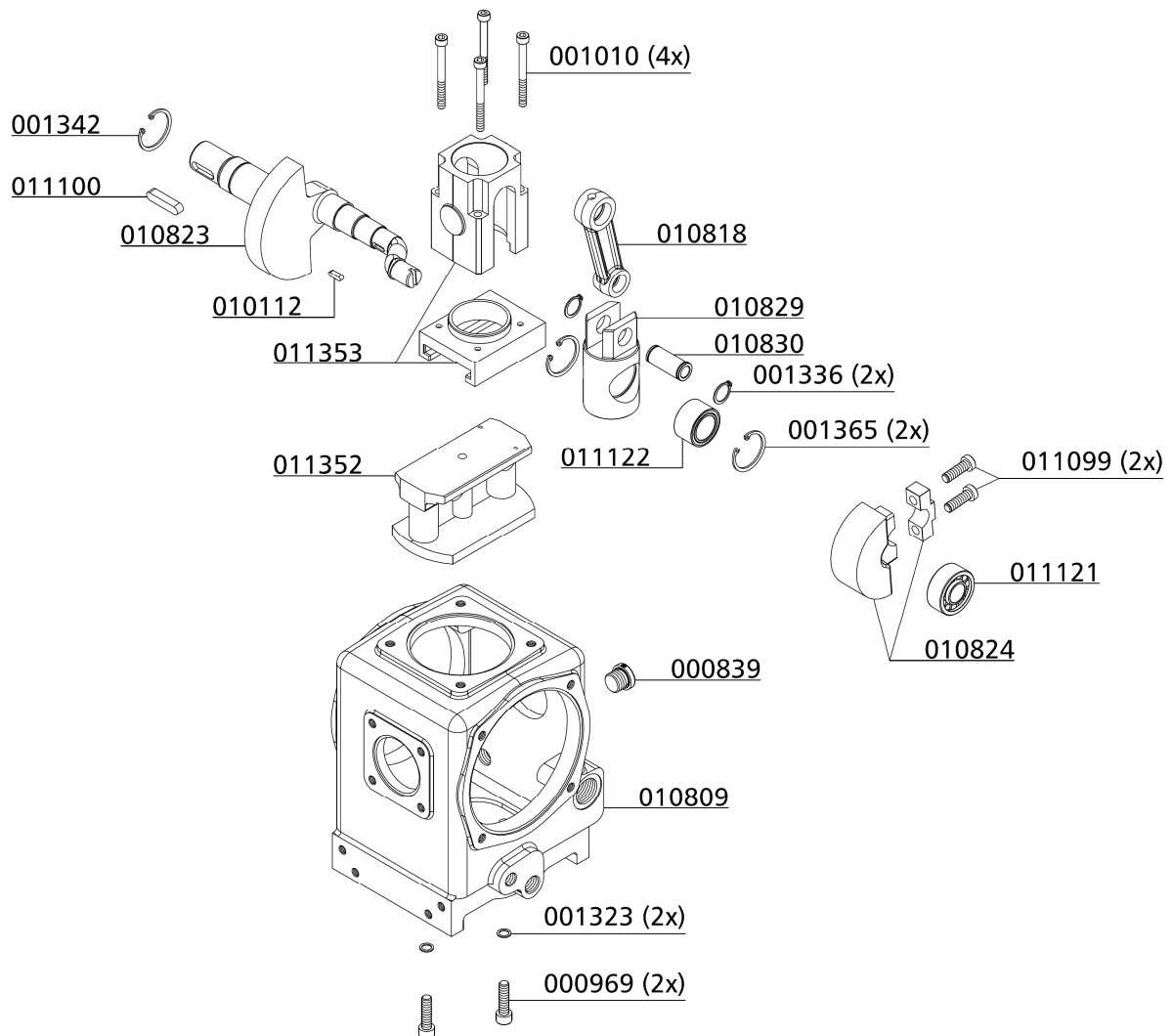

Baugruppe: Lagerdeckel schwungradseitig

Assembly: Bearing Cover Flywheel Side

Best.-Nr. / Order No.	Benennung	Description
001361	Sicherungsring I70	Circlip
010279	Sicherungsring I62	Circlip
010785	O-Ring Ø128x2mm	O-Ring
010821	Lagerdeckel	Bearing Cover Flywheel Side
010831	Wellendichtring 30x72x10RST	Shaft Seal
011119	Rillenkugellager 30x72x19mm	Bearing
011120	Zylinderrollenlager 30x62x16mm	Bearing

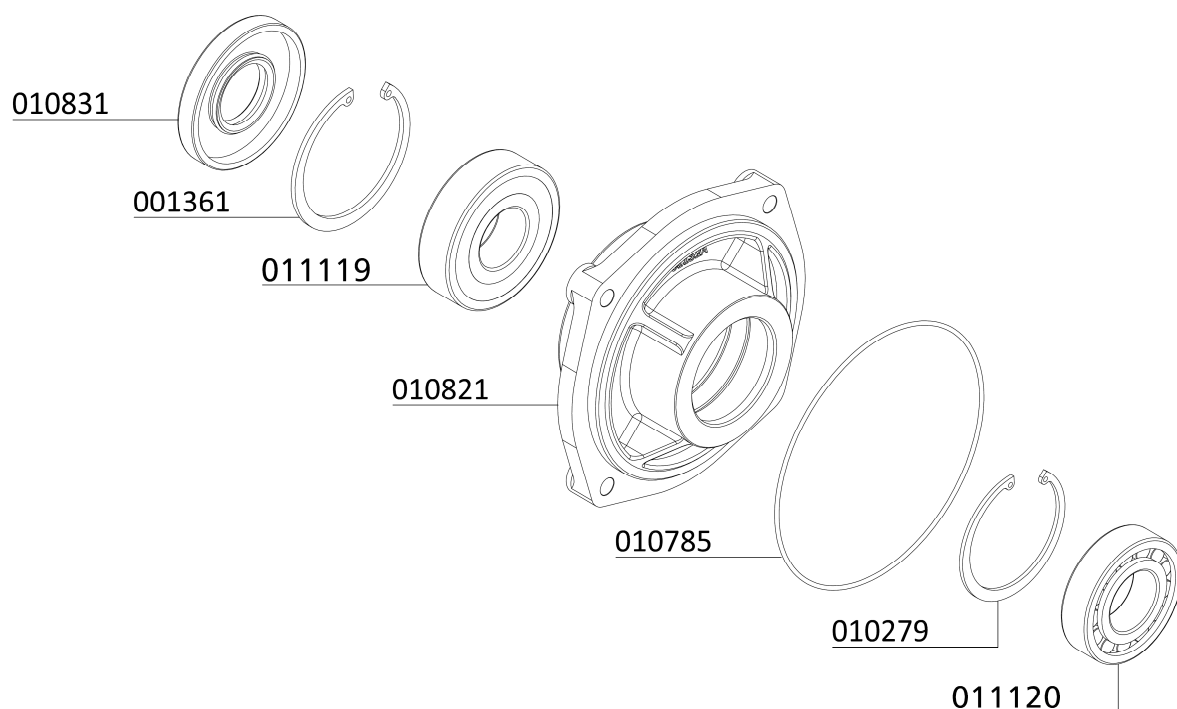



ERSATZTEILLISTE / SPARE PART LIST

Baugruppe: Kühler / Assembly: Cooler

Best.-Nr. / Order No.	Benennung	Description
000498	U-Scheibe A6	Washer
000735	Gerade Verschraubung G08L	Connection
001030	Zylinderschraube M6x16mm	Allen Bolt
001047	Zylinderschraube M6x12mm	Allen Bolt
001848	Rohrschelle (Ø15-18mm)	Pipe Clamp, 8mm Finned Pipe
009564	Rohrschelle Ø21, 12 breit	Pipe Clamp
010396	Kühler 1. Stufe, mit Muttern & Schneidr.	Cooler 1st Stage LW 200
010397	Kühler 2. Stufe, mit Muttern & Schneidr.	Cooler 2nd Stage LW 200
010425	Kühler 3. Stufe	Cooler 3rd Stage LW 200
011113	Halteblech Kühler	Holder Cooler

C

DETAILANSICHT / DETAILED VIEW

Baugruppe: Kühler / Assembly: Cooler

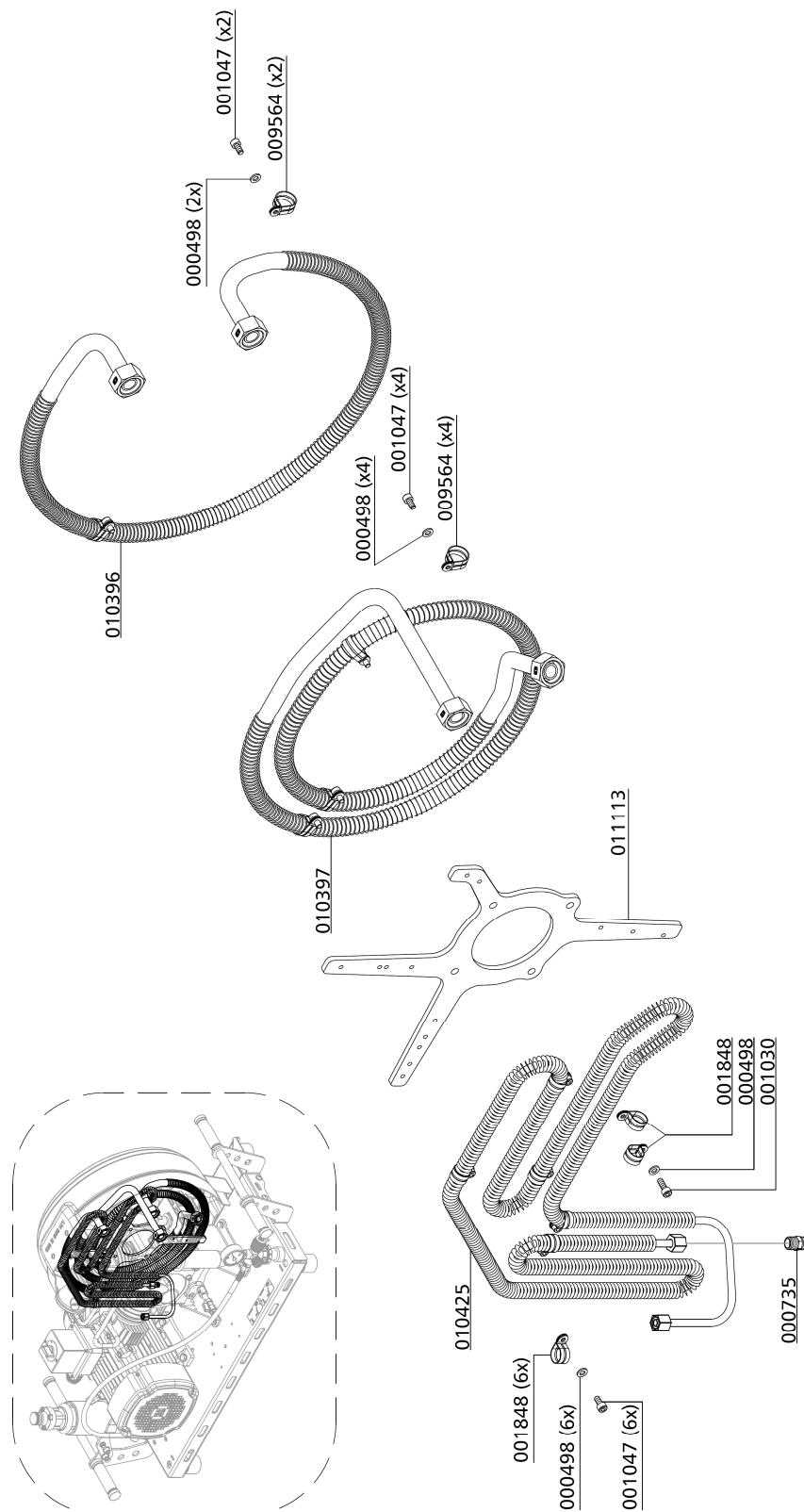

C

Baugruppe: Lüfterrad / Assembly: Flywheel Assembly

Best.-Nr. / Order No.	Benennung	Description
001043	Zylinderschraube M8x35	Allen Bolt
001184	Schnorr-Scheibe S8	Clamp Washer
003983	Scheibe Schwungrad	Washer, Flywheel
010898	Lüfterrad Ø460mm	Fan Wheel Ø460mm
011328	Anlegescheibe 3mm	Washer 3mm

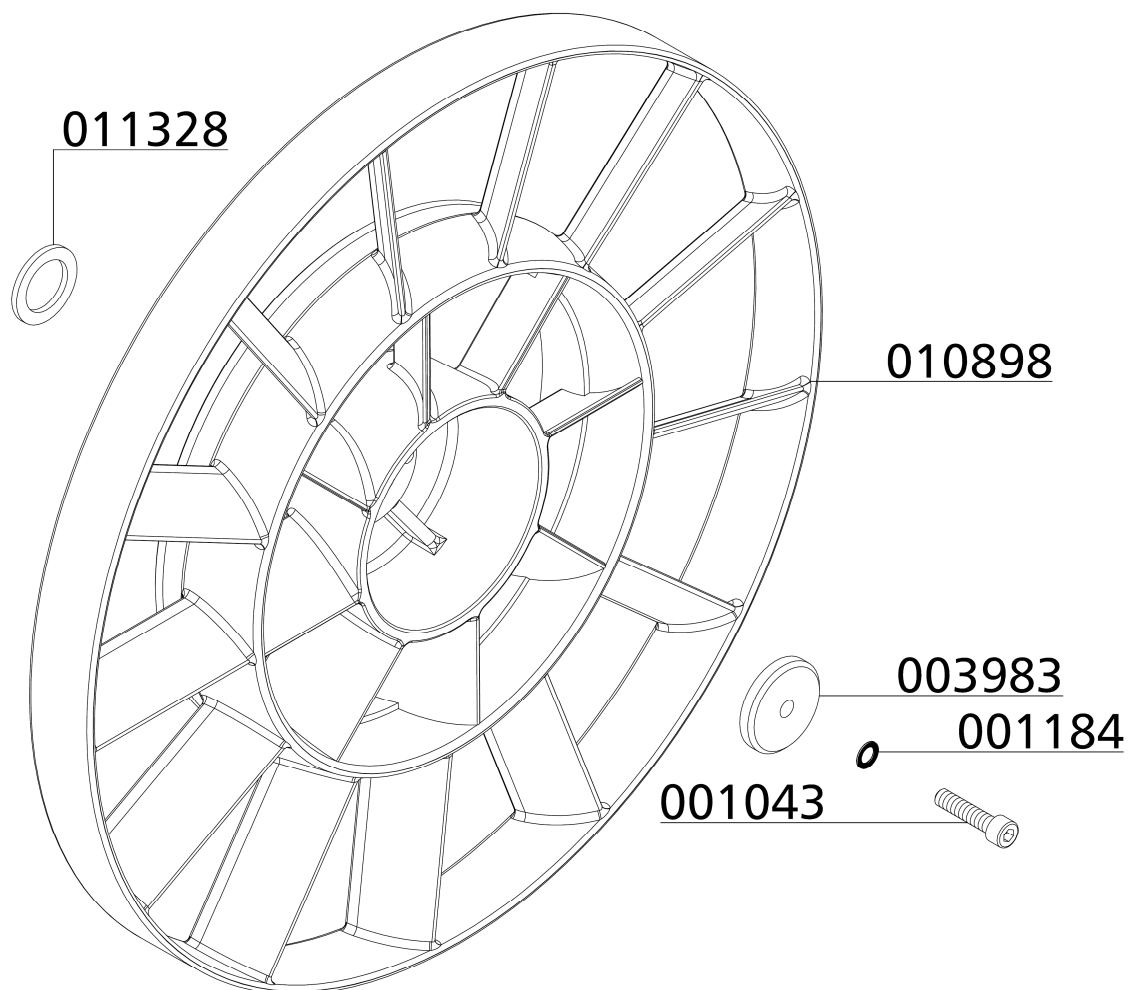



OPTIONS



Inhaltsverzeichnis

Additional Filling Hose	1
Auto Shut Down.....	4
Automatic Condensation Drain.....	7
Auto Start Function.....	14
Oil Pump.....	21
Oil Pressure Gauge	25
Oil Pressure Monitoring	28
Interstage Pressure Gauge	32
Cylinder Head Temperature Monitoring	36
Puracon Filter Monitoring	39
Switch Over Device 200+300bar.....	45
0.98 ltr final filter separator.....	49
Air Cooler Connection Kit.....	57
Wheel Set	61



ADDITIONAL FILLING HOSE

D



ADDITIONAL FILLING HOSE

The additional hose with filling valve allows to fill two bottles simultaneously. The hose with filling valve is available in 200 and 300 bar version.

Please refer to Chapter A for all information about the filling process.

Spare Part List

Best.-Nr. / Order No.	Benennung	Description
000498	U-Scheibe A6	Washer A6
001859	Befestigungsschraube Ø5,5x19	Fixing Bolt
002811	Hochdruckschlauch 1000mm 8S/10L	HP-Hose
006254	Füllventilhalter	Filling Valve Holder
007558	Verschraubung EW 10L	Connection
009827	Verschraubung EL10L	T-Connection

D

ADDITIONAL FILLING HOSE

Detailed View

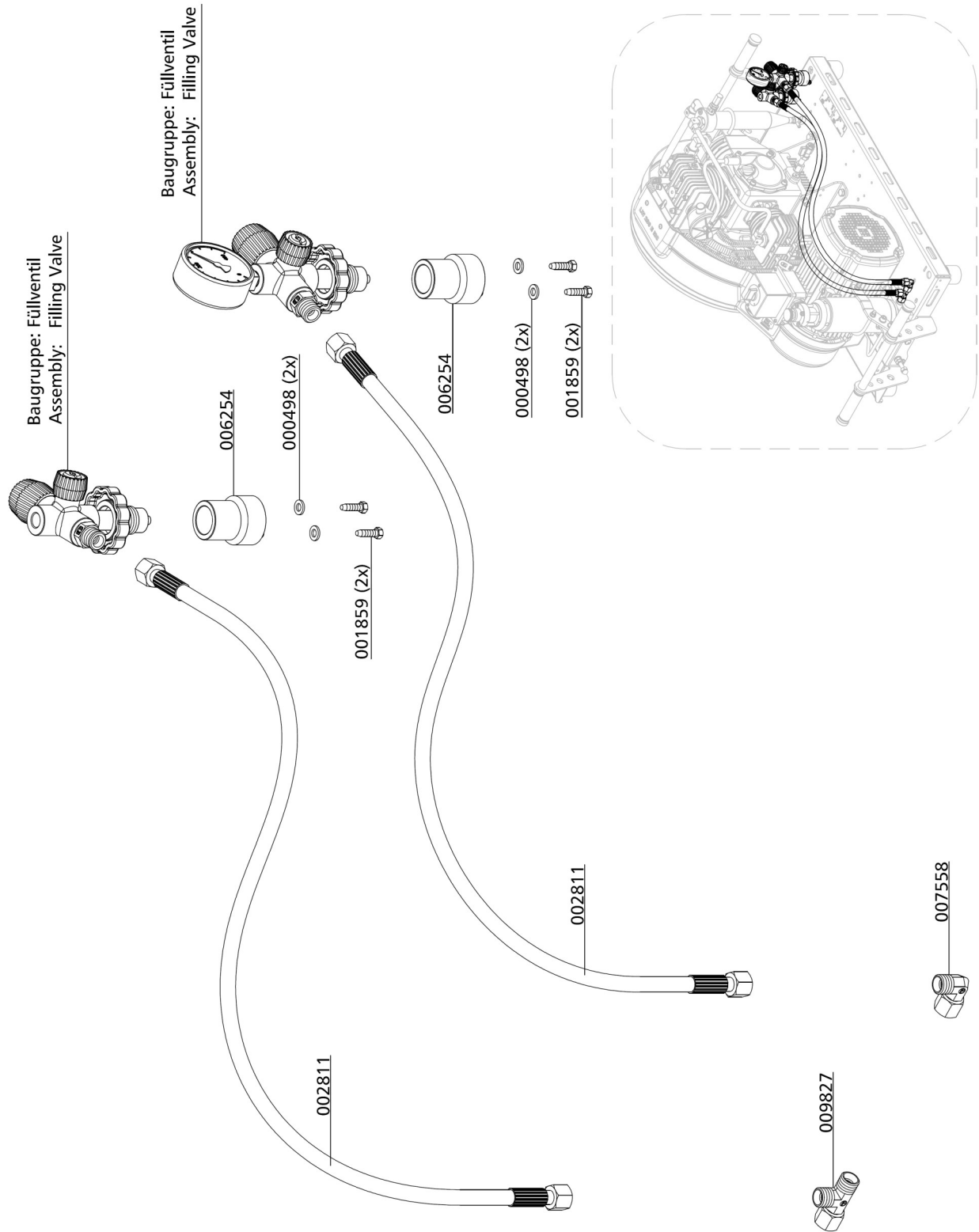

D



AUTO SHUT DOWN

D

AUTO SHUT DOWN

Final pressure switch

The pressure switch shuts off the compressor automatically when the selected final pressure is reached. The final pressure switch is already adjusted to the corresponding cut-out pressure.

The pressure can be adjusted with the upper adjusting screw as follows:

Increasing cut-out pressure:

Turn the adjusting screw clockwise.

Reducing cut-out pressure:

Turn the adjusting screw anti-clockwise.

Adjust the pressure switch in steps of a quarter turn.

Restart the compressor after every adjustment step to verify the actual cut-out pressure.

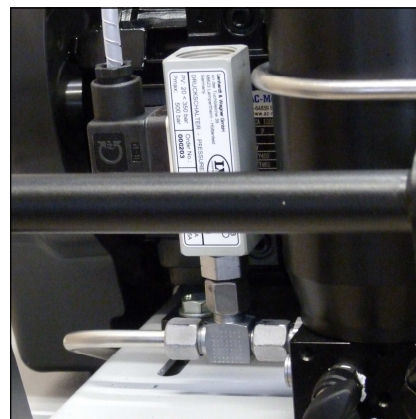

Final pressure switch

D



Note

Do not adjust the final pressure switch to the safety valve pressure. The final pressure switch has to be adjusted to min. 10 bar below the safety valve pressure. Otherwise, the safety valve can open during operation. This considerably reduces the life of the safety valve.

Example settings:

Safety valve	Max. Operating Pressure
225 bar	215 bar
250 bar	240 bar
330 bar	320 bar

AUTO SHUT DOWN

Spare Part List

Best.-Nr. / Order No.	Benennung	Description
000203	Druckschalter, PV 50 - 350 bar	Pressure Switch 50-350 bar
001176	U-Scheibe A5	Washer A5
008656	Rohrschelle Ø8mm / 12 mm breit	P-Clip
009682	Verschraubung EL08L	T-Connection
009683	Verschraubung EGE 08L	Connection with fixed nut
009760	Zylinderschraube M5x12mm	Allen Screw
011390	Rohrleitung Ø8mm, komplett mit M.&S.	Pipe Ø8mm, c/w Nut and Olive

D

Detailed View

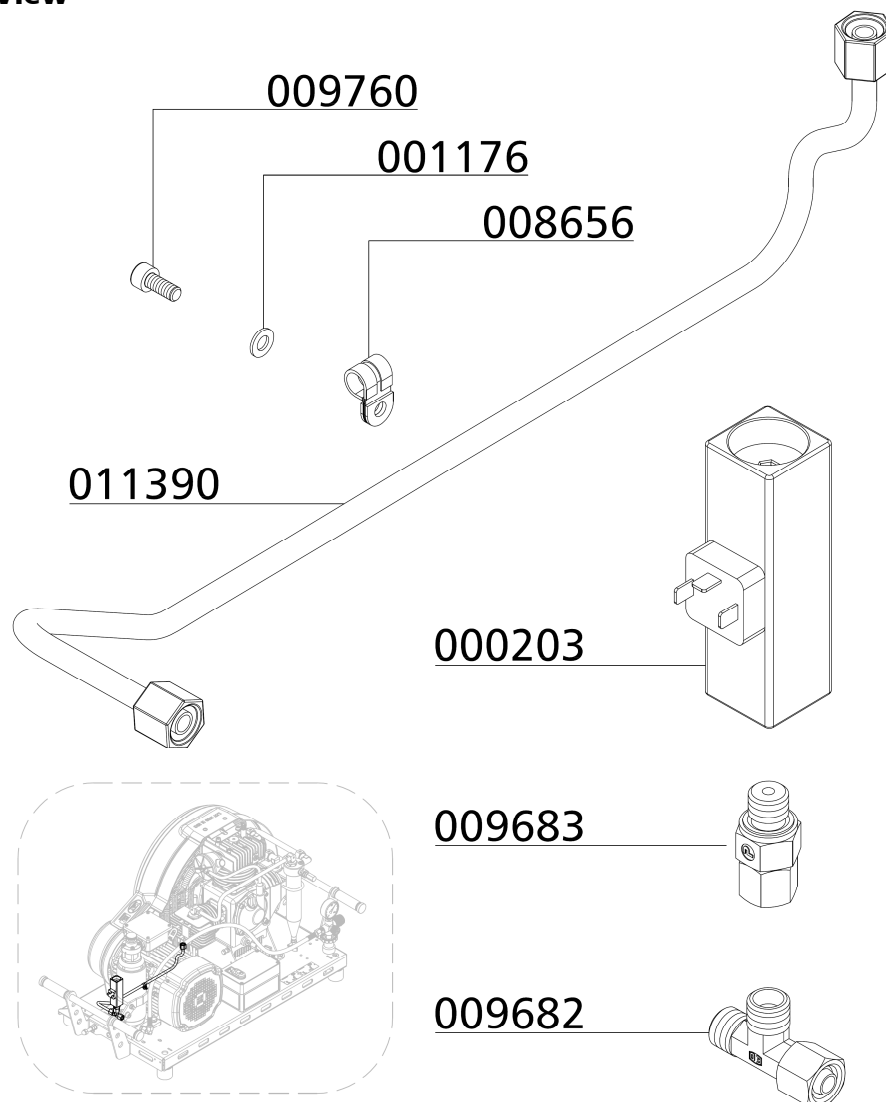



AUTOMATIC CONDENSATION DRAIN

D

AUTOMATIC CONDENSATION DRAIN

Automatic Condensation Dump System



Note

The collected condensate can contain oil and has to be disposed according to regulations.

The LW 150 - 200 - 250 E MC compressor can be optional equipped with an automatic condensation dump system. A solenoid valve drains the 2nd and 3rd condensate separators every 15 minutes.

To test the system, press the blue condensate test drain button on the control box.

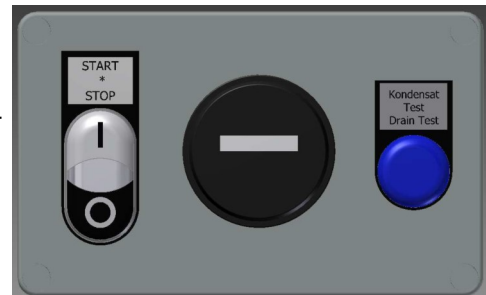

D

Oil / Water Separators

Condensate is separated after the 2nd and 3rd stage of compression. An electronic timer controlled the solenoid valve. The timer is located sideways at a small block and activates the dump valves about every 15 minutes.

To release the complete condensate through the black plastic hoses, we recommend using an 20 l container at least.

The drain noise can be kept to a minimum by using a silencer.

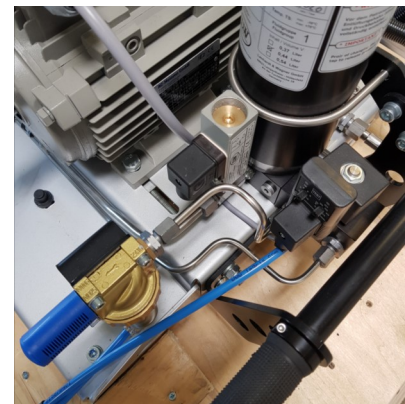

Automatic Condensate Drain System

Maintenance Intervals

We recommend to clean oil and water separators every 250 operating hours or at least once a year, to check for corrosion damage and to replace o-rings if necessary.

All oil / water separators have an integrated sinter filter which has to be replaced every 500 operating hours.



AUTOMATIC CONDENSATION DRAIN

Spare Part List

Best.-Nr. / Order No.	Benennung	Description
000498	U-Scheibe A6	Washer A6
000710	Verschraubung GE06L	Connection w/o nut& olive seal
000712	Verschraubung GE06LR1/4	Connection w/o nut& olive seal
000714	Verschraubung GE06SR3/8	Connection w/o nut& olive seal
001005	Zylinderschraube M5x16mm	Allen Screw
001006	Zylinderschraube M5x20mm	Allen Screw
001029	Zylinderschraube M6x20mm	Allen Bolt
001156	Stopfmutter M6, verzinkt	Lock Nut M6, zinc plated
001176	U-Scheibe A5	Washer A5
005854	Gerade Einschraubverschraubung 8 mm	Straight Hose Connection 8 mm
005856	Winkeleinschraubverschraubung 8 mm	Elbow Hose Connection 8 mm
008656	Rohrschelle Ø8mm / 12 mm breit	P-Clip
010411	Schalldämpfer G3/8"	Silencer G3/8"
011336	Halteblech Endabscheider G3/8"	Holder Oil- Water Separator
011467	Rohrleitung Ø8mm, komplett mit M.&S.	Pipe Ø8mm, c/w Nut and Olive
011468	Rohrleitung Ø6mm, komplett mit M.&S.	Pipe Ø6mm, c/w Nut and Olive
011469	Kondensatschlauch Ø8mm mit Aludüse	Condensate Hose Ø8mm

D

AUTOMATIC CONDENSATION DRAIN

Detailed View

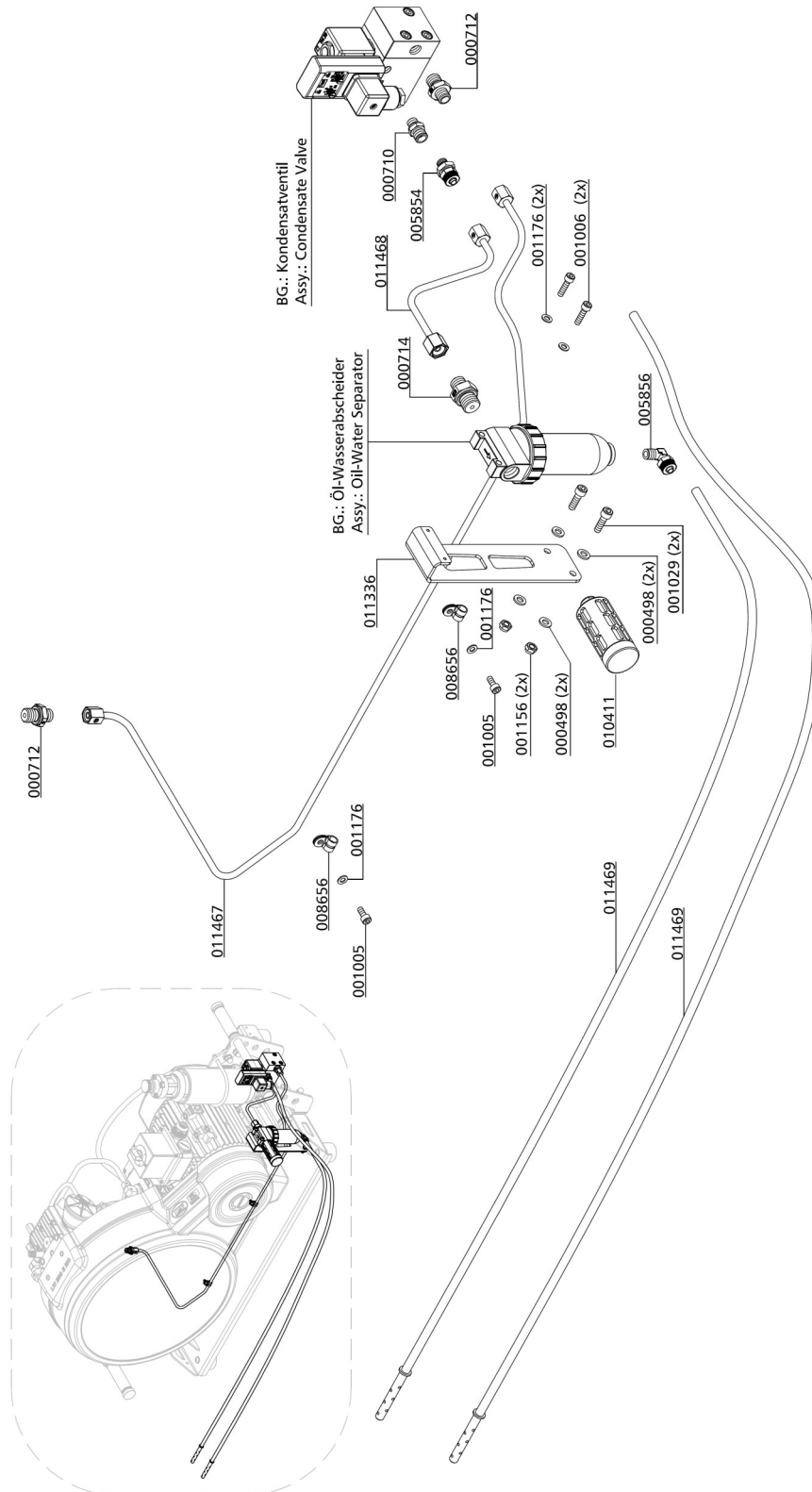

D



AUTOMATIC CONDENSATION DRAIN

Spare Part List

Best.-Nr. / Order No.	Benennung	Description
000602	Sandwichtimer	Timer 24-230V DC/AC
000607	Magnetspule NC 230V AC 40 bar TM30	Solenoid Coil NC 230V AC 40bar
000617	Stecker, Magnetventil DIN Form A	Plug for Solenoid Shape A
000999	Zylinderschraube M6x85mm	Allen Bolt
001234	O-Ring Ø10x2,5	O-Ring
001236	O-Ring Ø11x2	O-Ring
001238	O-Ring Ø12,42x1,78	O-Ring
001247	O-Ring Ø15x2,5	O-Ring
006294	Kondensatventil Gehäuse	Autom. Condens. Drain Housing
006295	Kondensatventil Deckel	Autom. Condens. Drain Cover
006296	Kondensatautomatik Steuerkolben	Autom. Condens. Drain Piston
006297	Kondensatautomatik Düse	Autom. Condens. Drain Jet
006298	Kondensatautomatik Sinterfilter	Autom. Condens. Drain Filter
008157	Magnetbolzen inkl. Kolben (Magnetventil)	Solenoid Pin incl. Piston

D

AUTOMATIC CONDENSATION DRAIN

Detailed View

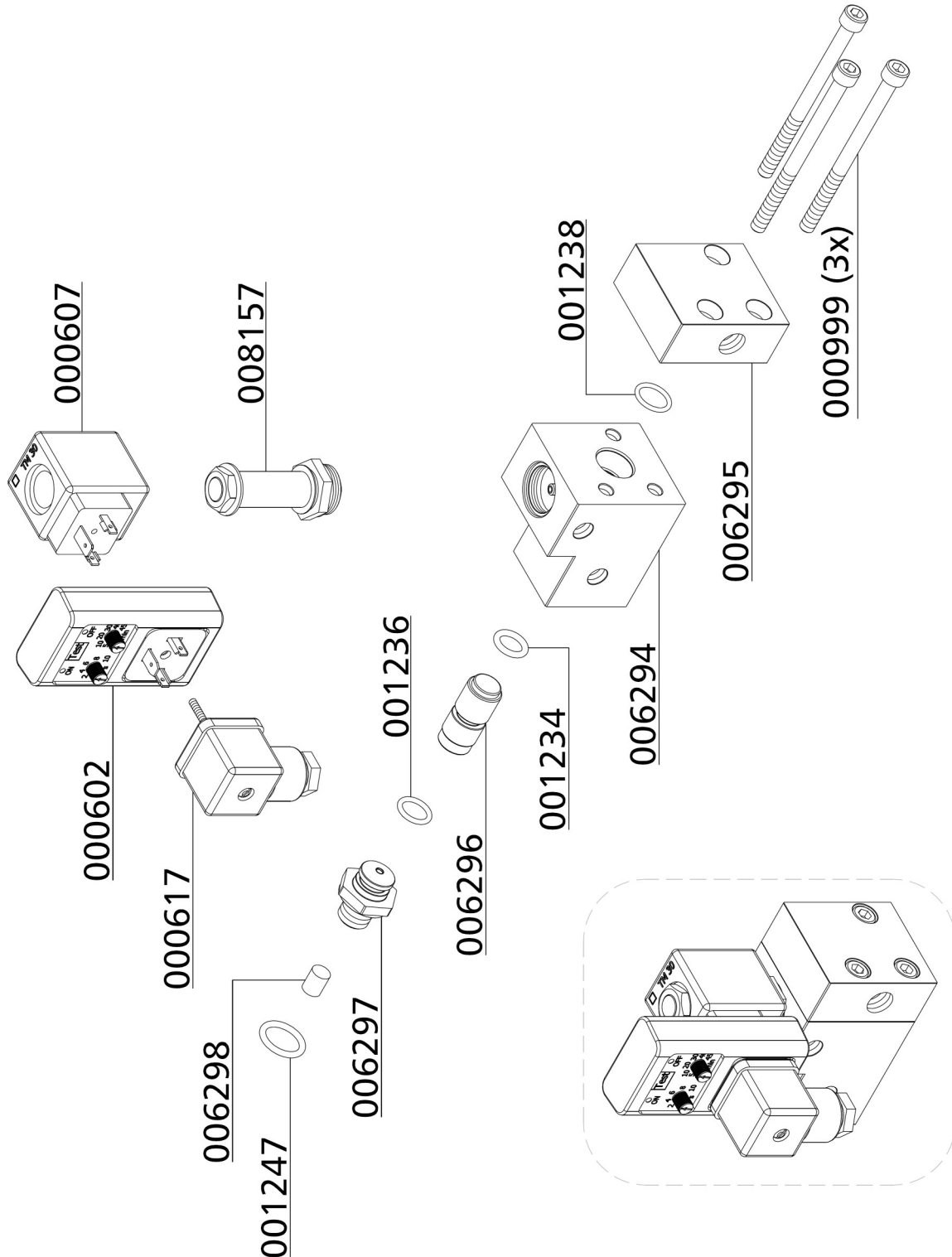

D

AUTOMATIC CONDENSATION DRAIN

Spare Part List

Best.-Nr. / Order No.	Benennung	Description
007368	Filter G3/8" mit Metallbehälter	Filter G3/8" c/w metal case
011004	Kleiner Wartungssatz für 007368	Small Maintenance Kit
011473	Großer Wartungssatz für 007368	Large Maintenance Kit

Detailed View

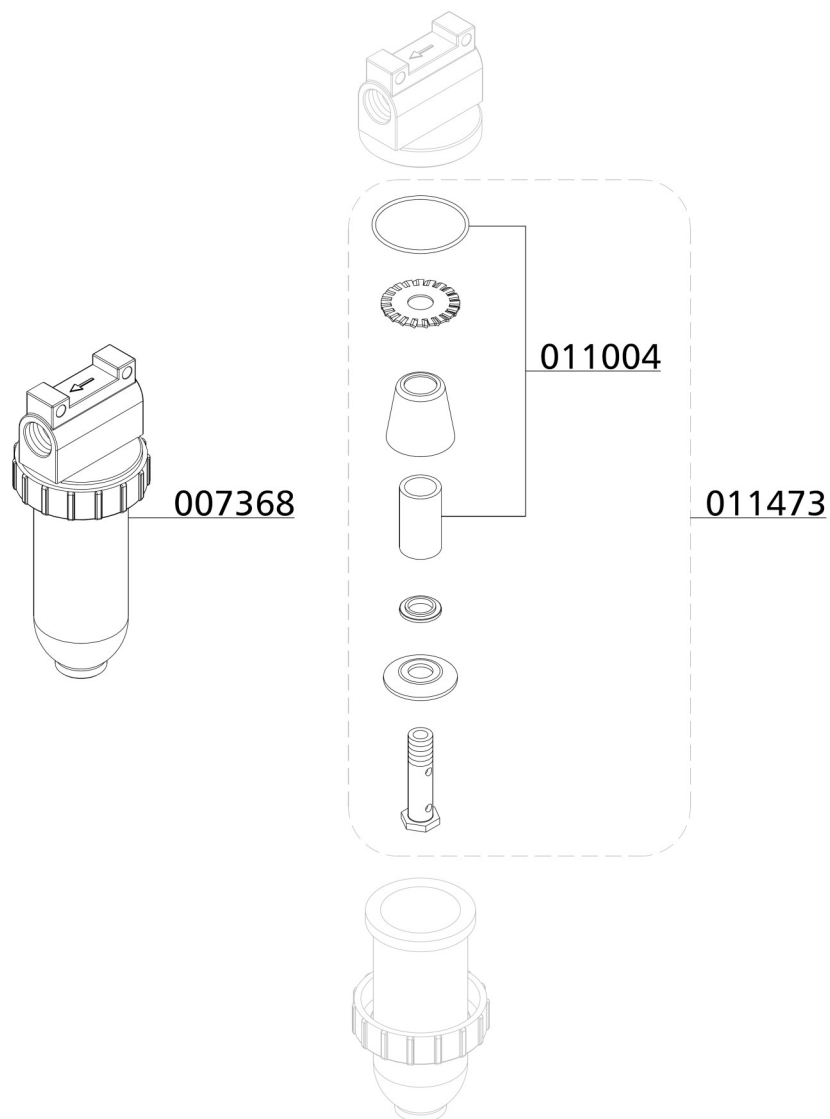

D



AUTO START FUNCTION

D

AUTO START FUNCTION

Auto Start Option requires external Electro Box

Auto Start Function

The auto start function allows operating the compressor optionally in automatic or semi-automatic mode by turning the selector switch.

Semi-automatic operation:

Start the compressor by pushing the Start button. The compressor automatically shuts off when final pressure is reached. To restart the compressor, push the Start button again. The unit can be shut down at any time during operation by pushing the Stop button.



Selector switch auto start function

Automatic operation:

Start the compressor only once by pushing the Start button. The Start button lights up and the unit automatically shuts off when final pressure is reached. If outlet pressure decreases below the selected minimum pressure, the unit automatically restarts.



Note

The compressor can not be manually started during automatic operation.

To enable a manual start, shut off automatic operation by pushing the Stop button (Start button lamp goes out). Now turn selector switch to semi-automatic mode and start the compressor with the Start button.

Adjust re-start pressure (minimum filling pressure)

The pressure switch for start pressure is located after the pressure maintaining valve. The pressure can be adjusted with the upper adjusting screw.

Increasing re-start pressure: turn adjusting screw clockwise

Reducing re-start pressure: turn adjusting screw anti-clockwise

Adjust pressure switch in steps of a quarter turn. Check settings after every adjustment step.

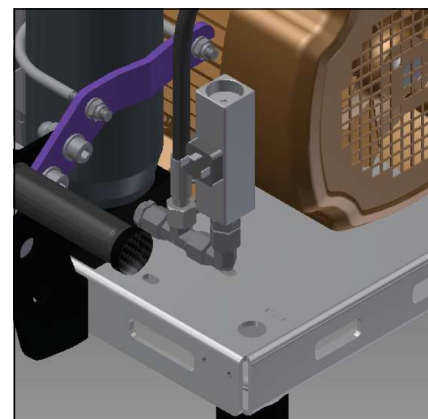

Adjust re-start pressure

AUTO START FUNCTION

Filling procedure semi-automatic operation



Caution! Only fill cylinders which:

- are marked with the test mark and the test stamp of the expert.
- have been hydro static tested (check last test date).
- are rated for the final pressure.
- are free from humidity.



Note

The unit shuts down when final pressure is reached. Thus, the unit always has to be restarted manually.

1. Turn selector switch to semi-automatic mode.
2. Close all filling valves.
3. Connect closed compressed air cylinders.
4. Open filling valves.
5. Start compressor by pushing the ON button.
6. When filling pressure gauge increases, open filling valves slowly.
7. Fill compressed air cylinders to the desired pressure, subsequently close filling valves slowly.
8. Close and vent all filling valves.
9. Disconnect all compressed air cylinders from filling valves.

AUTO START FUNCTION

Filling procedure automatic operation



Caution! Only fill cylinders which:

- are marked with the test mark and the test stamp of the expert.
- have been hydro static tested (check last test date).
- are rated for the final pressure.
- are free from humidity.



Note

The unit shuts down when final pressure is reached. Thus, the unit always has to be restarted manually.

1. Turn selector switch to automatic mode.
2. Close all filling valves.
3. Connect closed compressed air cylinders.
4. Open filling valves.
5. Start compressor by pushing the ON button.
6. When filling pressure gauge increases, open filling valves slowly.
7. Fill compressed air cylinders to the desired pressure, subsequently close filling valves slowly.
8. Close and vent all filling valves.
9. Disconnect all compressed air cylinders from filling valves.
10. If automatic operation is interrupted by:
 - pushing the OFF button
 - turning the selector switch
 - tripping the emergency shut-off switch
 - opening of the doors or the coverthe unit has to be restarted.



AUTO START FUNCTION

Spare Part List

Best.-Nr. / Order No.	Benennung	Description
000126	Y-Verteiler, schwarz eloxiert	Y-connector
000203	Druckschalter, G1/4" IG, PV 50 - 350 bar	Pressure Switch 50-350 bar
000498	U-Scheibe A6	Washer A6
000783	Gerade Verschraubung GE10L	Straight Connection
000797	Verschraubung EW10L	Elbow Connection
000799	Verschraubung EGE10L	Connection with fixed nut
001859	Befestigungsschraube Ø5,5x19	Fixing Bolt V-Belt Cover
002811	Hochdruckschlauch	HP-Hose
006254	Füllventilhalter	Filling Valve Holder
009827	Verschraubung EL10L	T-Connection

D

AUTO START FUNCTION

Detailed View

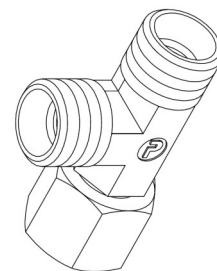
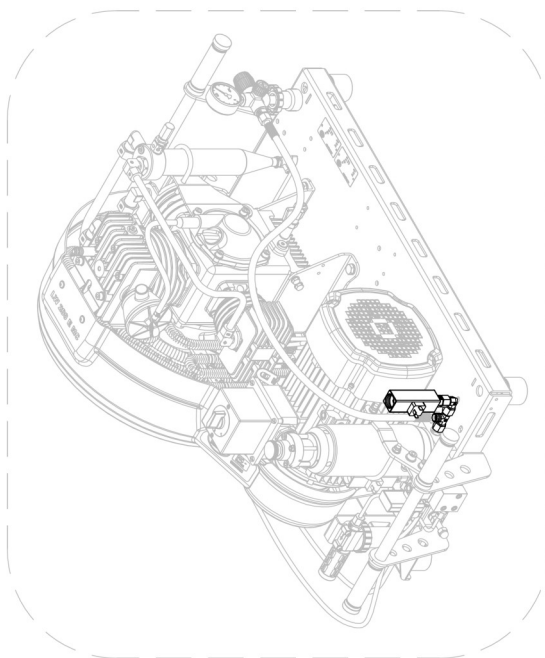
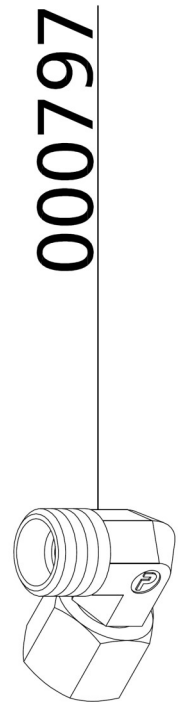
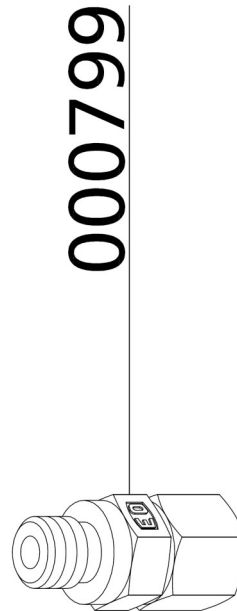
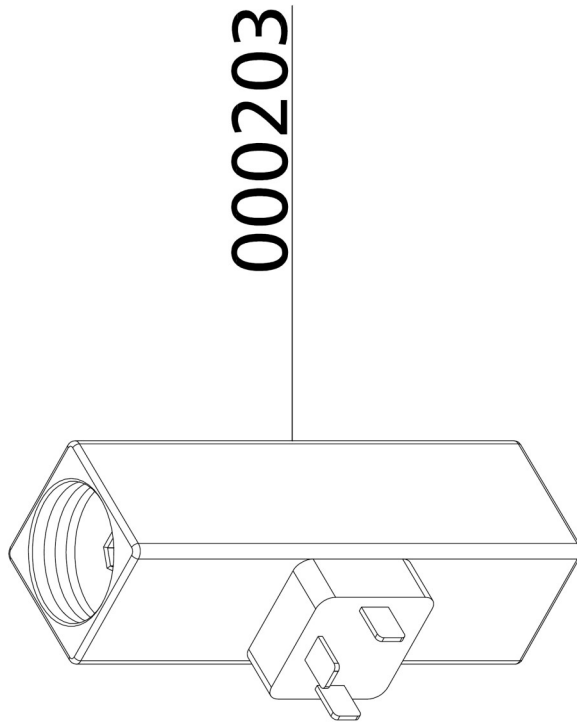

D

AUTO START FUNCTION

Detailed View

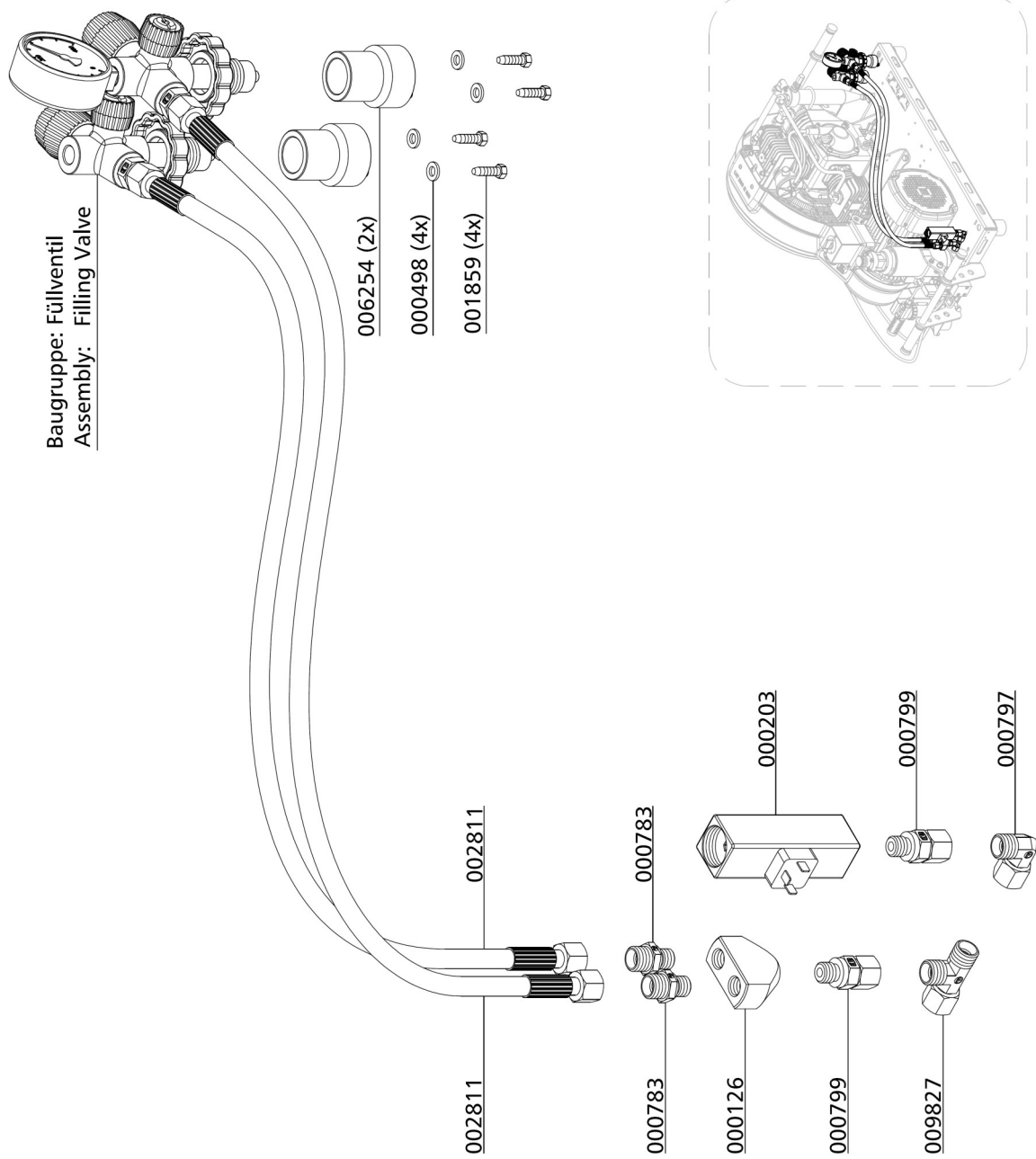

D



OIL PUMP

D

OIL PUMP

Maintenance and Service

Oil Sieve Change

Oil sieve change as follows:

- Loosen cover screws (Fig.1 / 4 pcs).
- Remove the cover, the cover gasket and the oil sieve.
- Clean the oil sieve with petroleum-ether or replace the defective oil sieve.
- Replace the gaskets.
- Soak the gaskets with oil before placing (respect mounting direction).
- Be sure to position the arrow from the new oil sieve opposite to inlet and return ports of the pump (see Fig.2).
- Remount the cover with the 4 cover screws. Tightening torque: 4.5 - 8 N.

The oil sieve change is now completed.

Maintenance intervals

- We recommend cleaning or replacing the oil sieve every 1,000 working hours.
- Service Kit oil pump (002569). Consists of: 000798—Oil sieve + 000672—oil pump cover gasket.



Fig. 1



Fig. 2



OIL PUMP

Spare Part List

Best.-Nr. / Order No.	Benennung	Description
000204	Ölpumpe, kompl.	Oil Pump compl.
000721	Verschraubung	Connection
000958	Gewindestift, Madenschraube	Hexagon Socket Screw
001041	Zylinderschraube	Allen Screw
001042	Zylinderschraube	Allen Screw
001181	U-Scheibe A8	Washer A8
001323	CU-Ring	Copper Seal Ring
001327	CU-Ring	Copper Seal Ring
001329	CU-Ring	Copper Seal Ring
002340	O-Ring Ölpumpenflansch	O-Ring, oil pump flange
005272	Hohlschraube G1/4" - AG	Banjo Bolt G1/4" - male
010785	O-Ring	O-Ring
010820	Lagerdeckel	Bearing Cover Oil Pump Side
010822	Ölpumpen-Mitnehmer	Oil Pump Driver
011106	Anschlussadapter	Adapter Crankcase Vent
011110	Verschlusschraube GN 441, 3/4"	Plug G3/4
011121	Zylinderrollenlager 17x40x16 mm	Bearing
011227	Spezialschraube M10	Special Bolt M10
011402	Ölansaugschlauch, Block - Ölpumpe	Oil Suction Hose
011403	Rohrleitung Ø6mm, komplett mit M.&S.	Pipe Ø6mm, c/w Nut and Olive
011404	Gewindestift M6x8	Threaded Pin

D

OIL PUMP

Detailed View

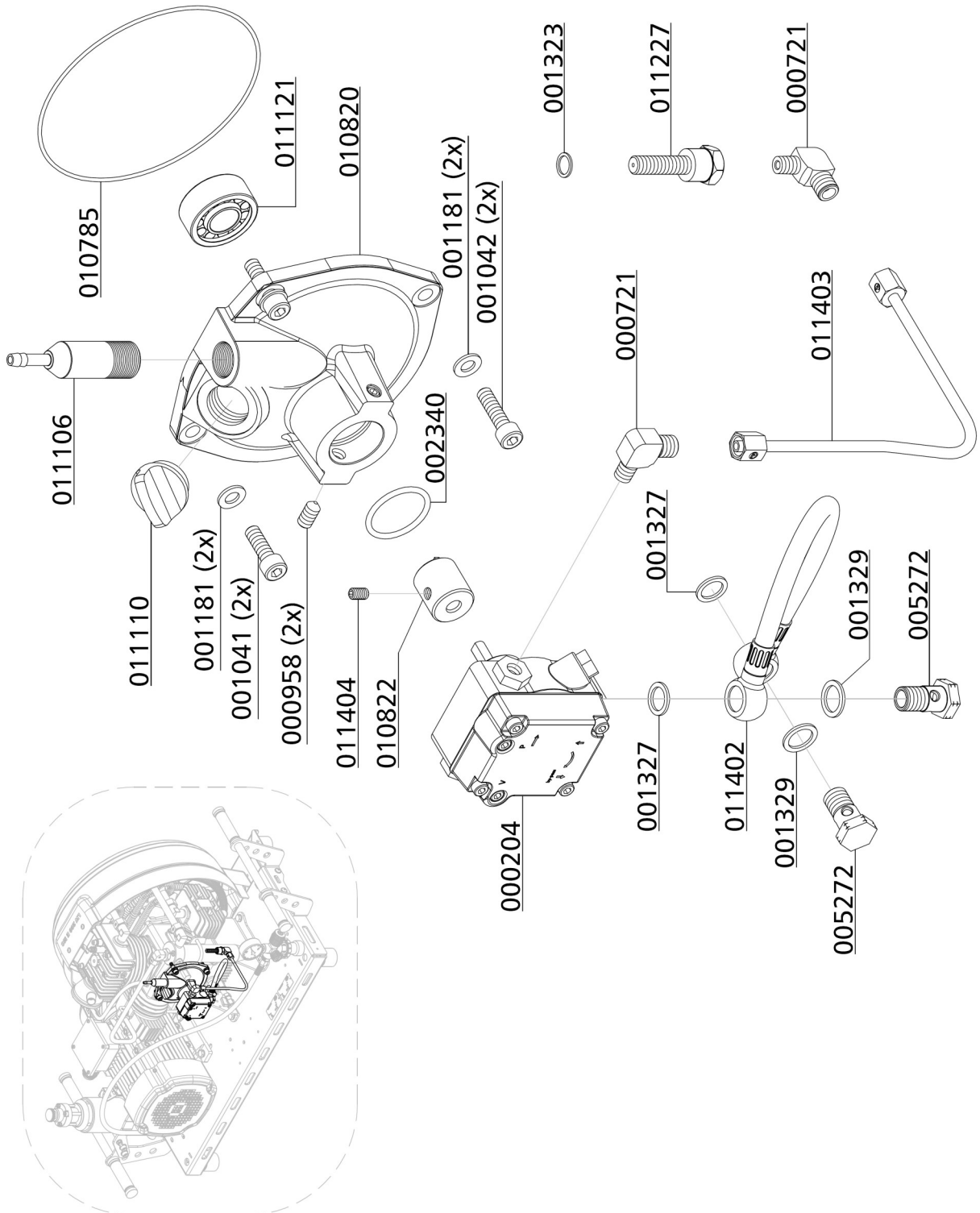

D



OIL PRESSURE GAUGE

D

OIL PRESSURE GAUGE

Oil pressure gauge

The oil pressure gauge shows the compressor oil pressure during operation. Oil pressure values should remain between:

- min. + 1,0 bar
- max. + 2,0 bar

If oil pressure value stays below the minimum value:

- Wrong compressor rotation direction (see rotation direction arrow)
- Oil level too low, not enough oil in the compressor
- Oil pump filter contaminated
- Oil intake pipe damaged / defective
- Oil temperature below +5 °C - lubrication not possible
- Oil temperature higher than +120 °C - oil viscosity too low
- Oil pump defective

If oil pressure value stays above the maximum value:

- Low oil temperature, between +5 °C and +10 °C
- Should stay within the range of tolerance when operation temperature is reached..

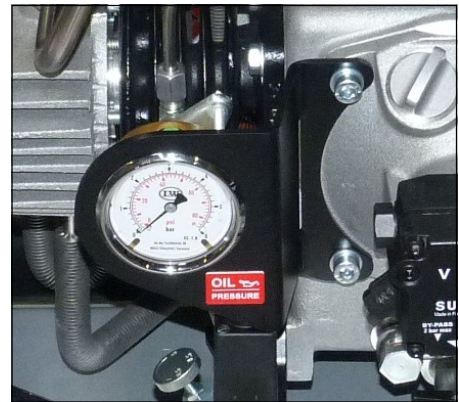

Oil pressure gauge

OIL PRESSURE GAUGE

Spare Part List

Best.-Nr. / Order No.	Benennung	Description
000655	Einbaumanometer mit Befestigungsbügel 0-6bar	Press.Gauge, glycerine, brass
000716	Verschraubung TE06L	Connection w/o nut& olive seal
001042	Zylinderschraube M8x30mm	Allen Screw
001181	U-Scheibe A8	Washer
002281	Verschraubung EW06L	Connection with fixed nut
011335	Halter Öldruckmanometer	Holder Oil Pressure Gauge
011463	Rohrleitung Ø6mm, komplett mit M.&S.	Pipe Ø6mm, c/w Nut and Olive

D

Detailed View

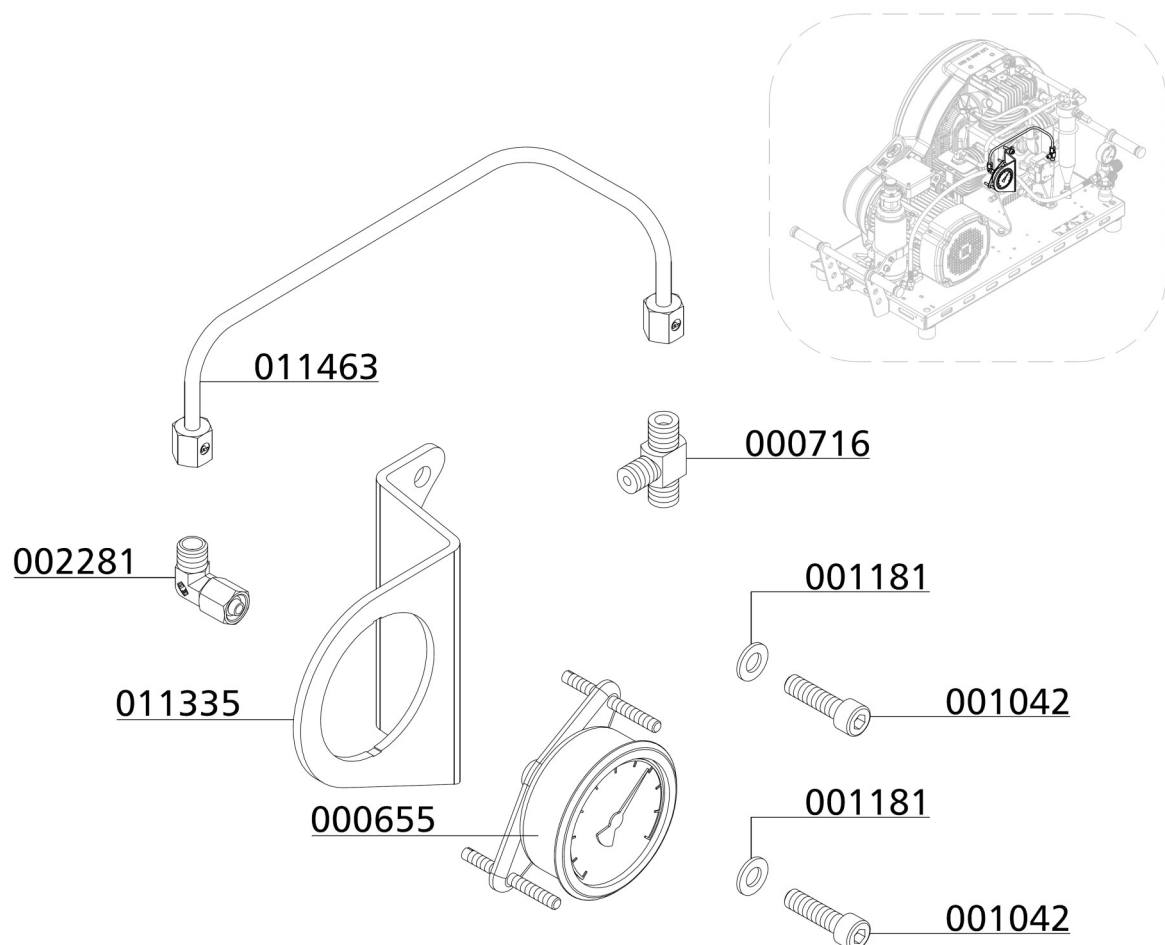



OIL PRESSURE MONITORING

D

OIL PRESSURE MONITORING

Oil pressure monitoring

The oil pressure is maintained by a pressure switch during operation. The compressor automatically shuts off when oil pressure decreases below the minimum pressure of +0.5 bar. The red warning lamp "Oil Pressure Monitoring" lights up.

Possible causes of fault:

- Wrong compressor rotation direction
(see rotation direction arrow)
- Oil level too low, not enough oil in the compressor
- Oil pump sieve contaminated
- Oil intake hose damaged / defective
- Oil temperature below +5 °C - lubrication not possible
- Oil temperature higher than +120 °C - oil viscosity too low
- Oil pump defective



Oil Pressure Monitoring

OIL PRESSURE MONITORING

Spare Part List

Best.-Nr. / Order No.	Benennung	Description
000716	Verschraubung TE06L	Connection w/o nut& olive seal
001022	Zylinderschraube M5x45mm	Allen Bolt
001152	Stopfmutter M5	Lock Nut
001176	U-Scheibe A5	Washer
005261	Druckschalter inkl. Stecker	Oil Pressure Switch 0.2-2 bar
008995	Winkelverschraubung WE06LR1/4"	Elbow Connection
011465	Rohrleitung Ø6mm, komplett mit M.&S.	Pipe Ø6mm, c/w Nut and Olive

D

Detailed View

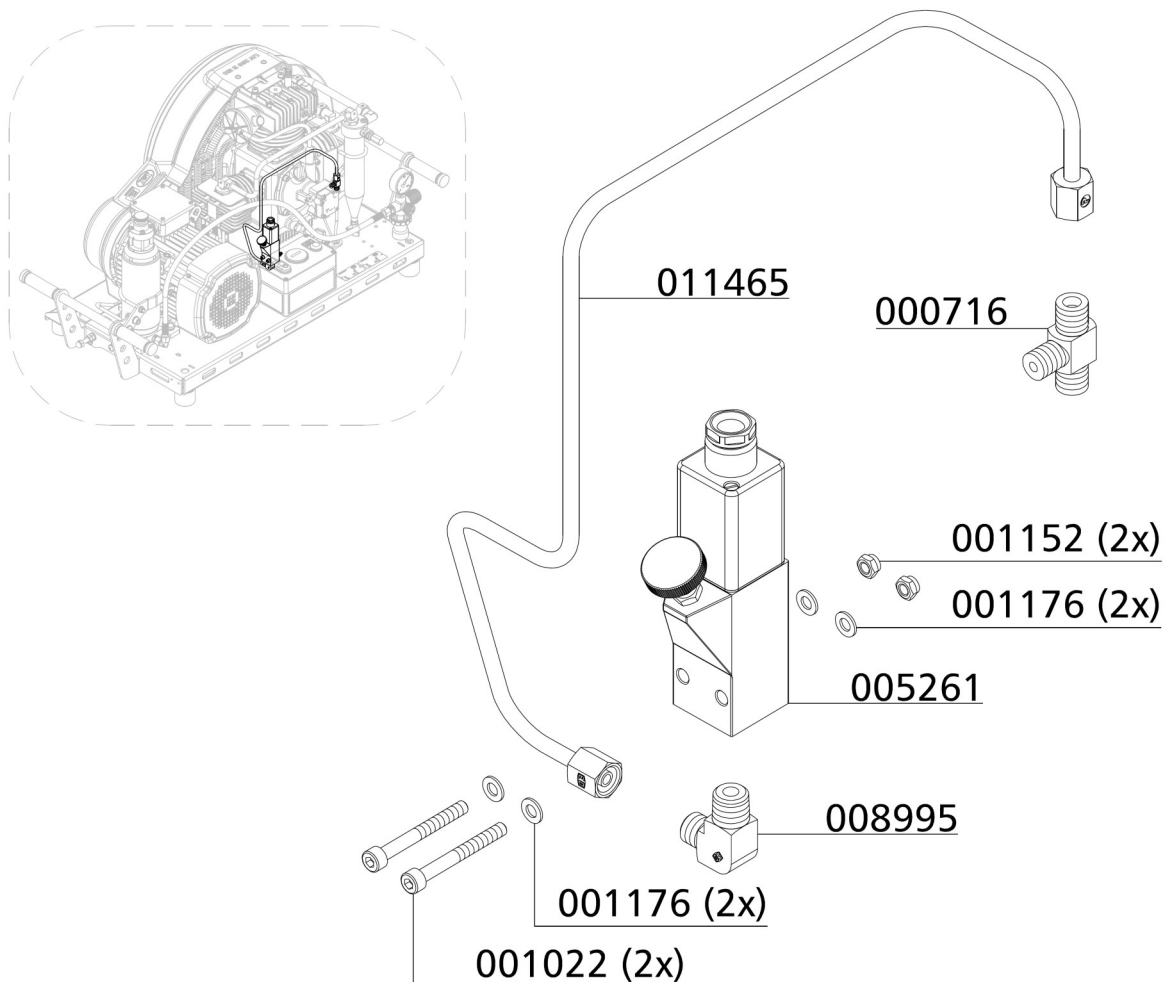

OIL PRESSURE MONITORING WITH OIL PRESSURE GAUGE

Spare Part List

Best.-Nr. / Order No.	Benennung	Description
000720	Verschraubung ET06L	Connection with fixed nut
001022	Zylinderschraube M5x45mm	Allen Bolt
001152	Stopfmutter M5	Lock Nut
001176	U-Scheibe A5	Washer
005261	Druckschalter inkl. Stecker	Oil Pressure Switch 0.2-2 bar
008995	Winkelverschraubung WE06LR1/4"	Elbow Connection
011464	Rohrleitung Ø6mm, komplett mit M.&S.	Pipe Ø6mm, c/w Nut and Olive

D

Detailed View

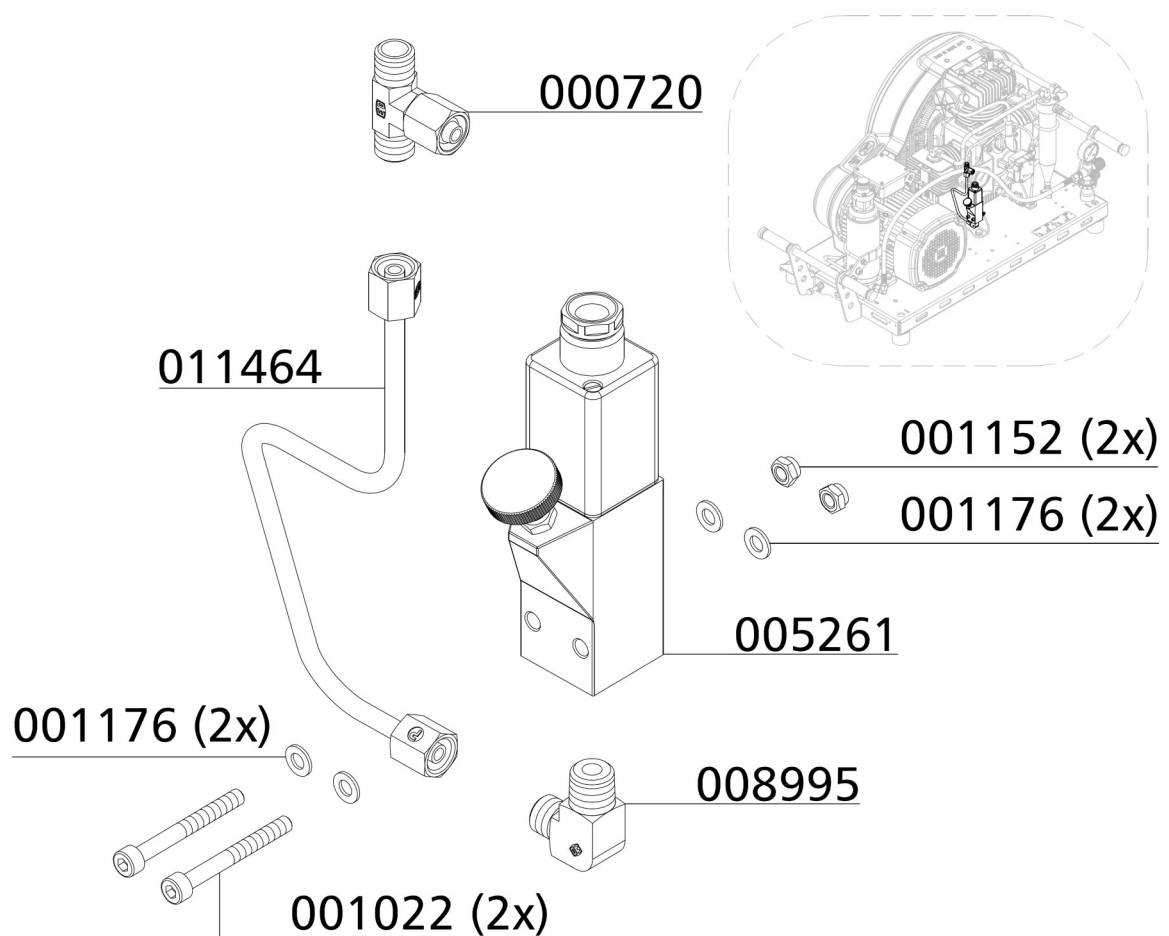



INTERSTAGE PRESSURE GAUGE

D

INTERSTAGE PRESSURE GAUGE

Interstage pressure gauge

Each of the 3 pressure stages is monitored by a single pressure gauge. This is serviceable for troubleshooting and allows detecting faults at an early stage.



Indicated interstage pressures depend on final pressure settings.

The pressure gauges should show the following values at a final pressure of 300 bar:

1st stage: approx. 5 bar

2nd stage: approx. 60 bar

3rd stage: approx. 300 bar



INTERSTAGE PRESSURE GAUGE

Spare Part List

Best.-Nr. / Order No.	Benennung	Description
000710	Verschraubung GE06L	Connection w/o nut & olive seal
001446	Manometerschlauch 700mm	Pressure Gauge Hose
002281	Verschraubung EW06L	Connection with fixed nut
002507	Einbaumanometer mit Befestigungsbügel 0-10bar	Pressure Gauge 0-10bar
005539	Einbaumanometer mit Befestigungsbügel 0-100bar	Pressure Gauge 0-100bar
011258	Halblech Zwischendruckmanometer	Holder 1st & 2nd Pressure Gauge

D

INTERSTAGE PRESSURE GAUGE

Detailed View

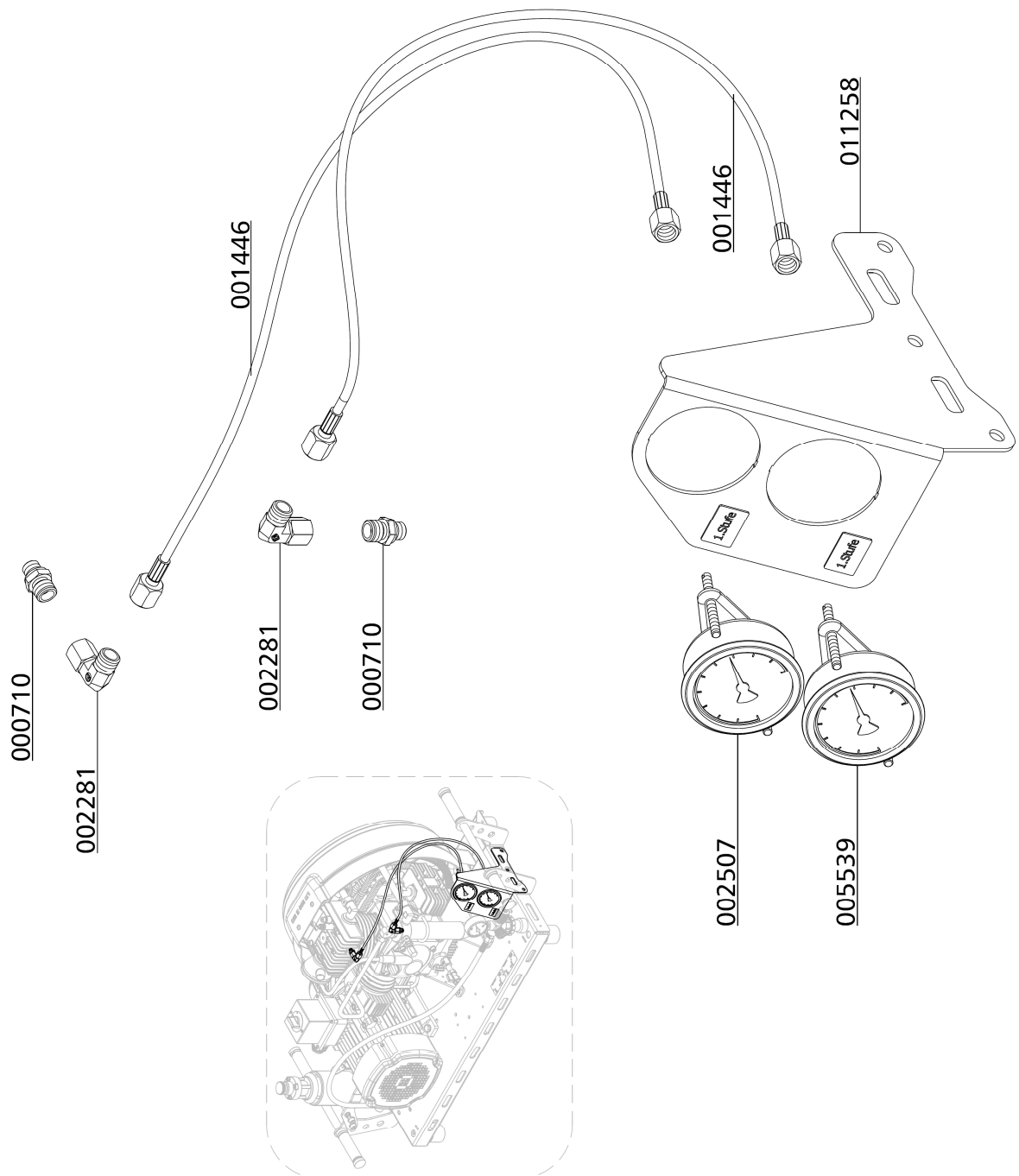

D



CYLINDER HEAD TEMPERATURE MONITORING

D

CYLINDER HEAD TEMPERATURE MONITORING

Cylinder head temperature monitoring

The cylinder head temperature is maintained by a temperature sensor at the cylinder head of the high pressure stage during operation. The compressor shuts off automatically when cylinder head temperature exceeds the maximum pressure of +120° C. The red warning lamp "Cylinder Head Temperature Monitoring" lights up.

Possible causes of fault:

- Ventilation of the compressor room is not sufficient
- Cooling air flow not sufficient
- Cooling pipes contaminated



Warning

Risk of burns!

Allow the unit to cool before beginning troubleshooting.

CYLINDER HEAD TEMPERATURE MONITORING

Spare Part List

Best.-Nr. / Order No.	Benennung	Description
000987	Zylinderschraube M4x16mm	Allen Bolt
001175	U-Scheibe A4	Washer
010927	Temperatursensor, ECC, RTC, Standard PT1000, 3m Kabel	Temp. Sensor Cylinder Head
011332	Klemmenkasten	Terminal Box
011727	Temperatursensor, ECC, RTC, Standard PT1000, 10m Kabel	Temp. Sensor Cylinder Head
011833	Temperaturanzeige digital ohne Sensor	Temperature Digital Display

D

Detailansicht

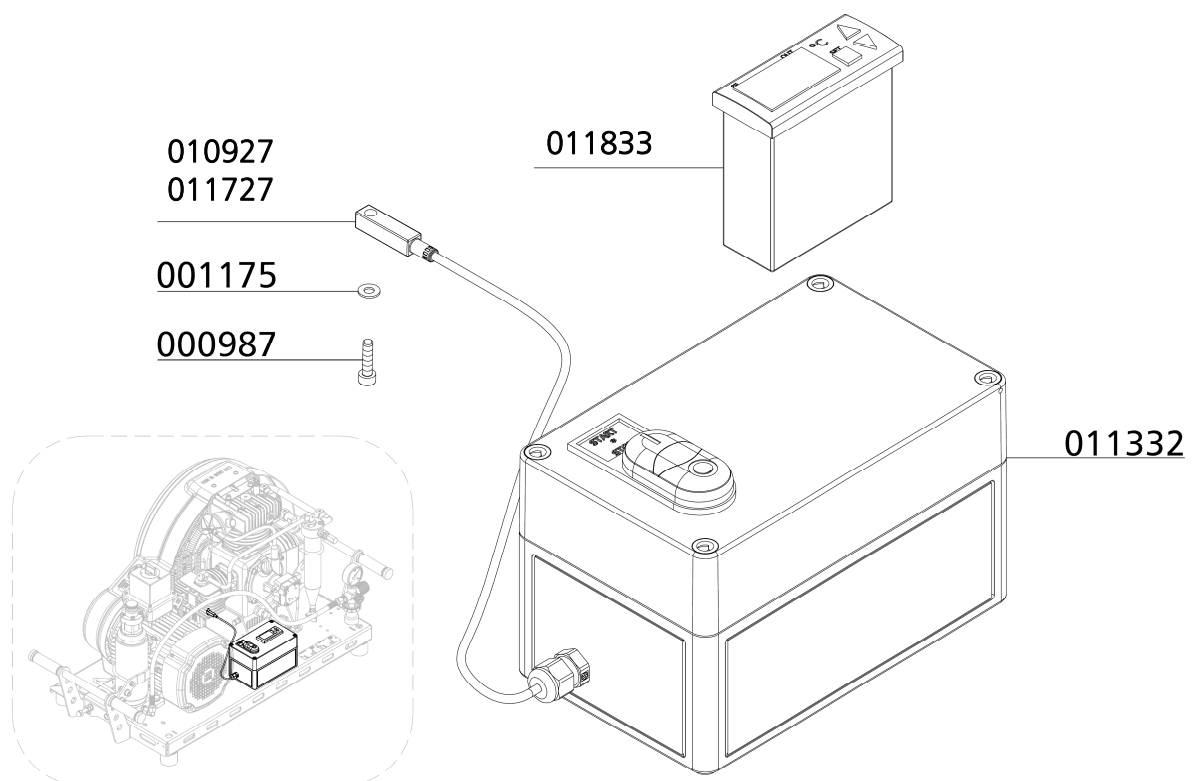



PURACON FILTER MONITORING

D

PURACON FILTER MONITORING

Puracon Filter Monitoring

The usage of a humidity controller is the most reliable and economic method for filter monitoring.

Puracon Stationary PRO

Puracon Stationary PRO is the professional solution for humidity monitoring during the filling procedure. The PRO version provides separated sensor and display unit. The sensor is connected directly to the high-pressure line after the humidity filter and is linked to the display unit via a data cable.



Puracon Stationary PRO

Specifications

- Stainless steel sensor housing with screw joint and G1/4" inlet and outlet
- Display unit (120 x 120 x 60 mm) for wall mounting with sensor cable (length: 2 m)
- Power supply cable (length: 1.2 m) with CE plug 230 V AC ~ 50/60 Hz (12/24V DC versions available)
- Digital LCD display with humidity display in mg/m³ and error warnings
- Pressure compensation
- 3 monitoring LEDs, adjustable limits
- Language can be selected in German, English, French or Spanish
- Sensor cables with 5, 10, 15 or 30 m available for surcharge
- Approved up to 420 bar

Available Versions

- 230 V AC, 12 V DC, 24 V DC
- Ex with ATEX certification

Technical Data	Puracon Stationary PRO
Operating pressure	150 to 420 bar - adjustable pressure range
Power supply	240VAC / optional 12V or 24VDC
Connector	Sensor: G1/4 thread
Protection rating	IP64
Operating temperature	-10°C to +40°C



PURACON FILTER MONITORING

Spare Part List

Best.-Nr. / Order No.	Benennung	Description
000126	Y-Verteiler, schwarz eloxiert	Y-connector
000498	U-Scheibe A6	Washer
000761	Winkelverschraubung WE08L	Elbow Connection
000783	Gerade Verschraubung GE10L	Straight Connection
000799	Verschraubung EGE10L	Connection with fixed nut
001040	Zylinderschraube M8x20mm	Allen Screw
001055	Zylinderschraube M8x55mm	Allen Bolt
001159	Stopfmutter M8	Lock Nut
001181	U-Scheibe A8	Washer
001859	Befestigungsschraube Ø5,5x19	Fixing Bolt V-Belt Cover
002811	Hochdruckschlauch	HP-Hose
006254	Füllventilhalter	Filling Valve Holder
007558	Verschraubung EW10L	Connection
011474	Rohrleitung Ø8mm, komplett mit M.&S.	Pipe Ø8mm, c/w Nut and Olive

D

PURACON FILTER MONITORING

Detailed View

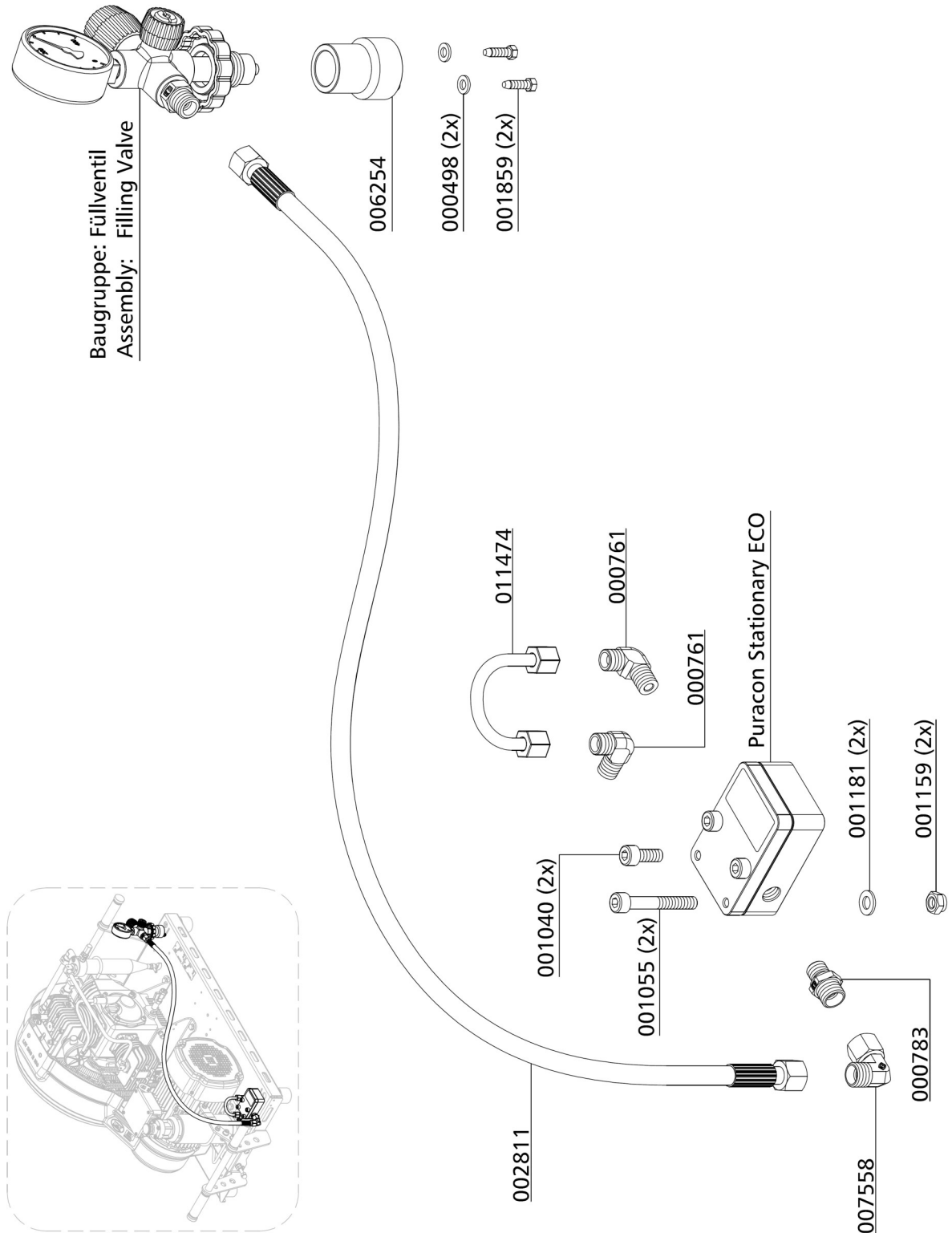

D

PURACON FILTER MONITORING

Detailed View

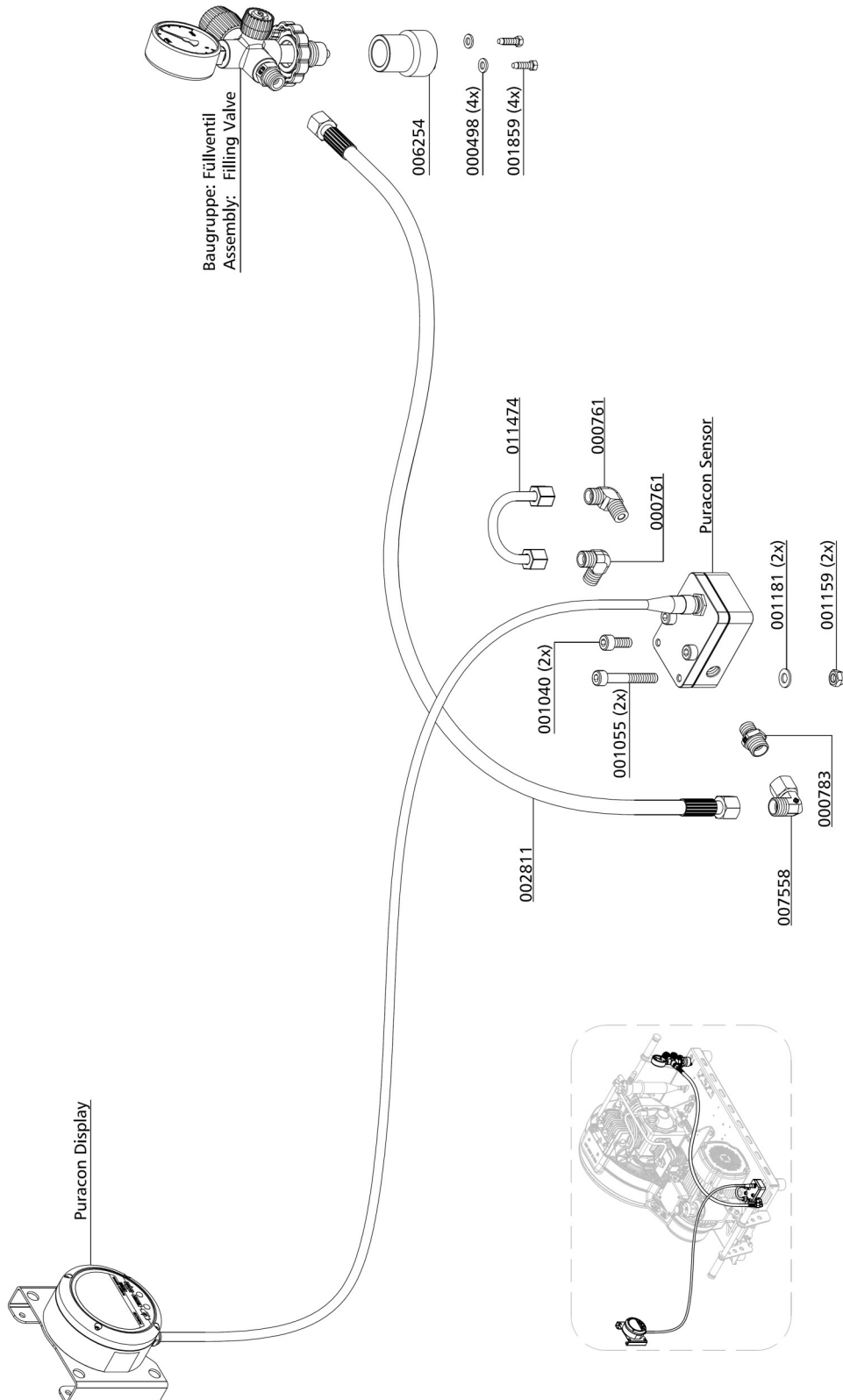

D

PURACON FILTER MONITORING

Detailed View

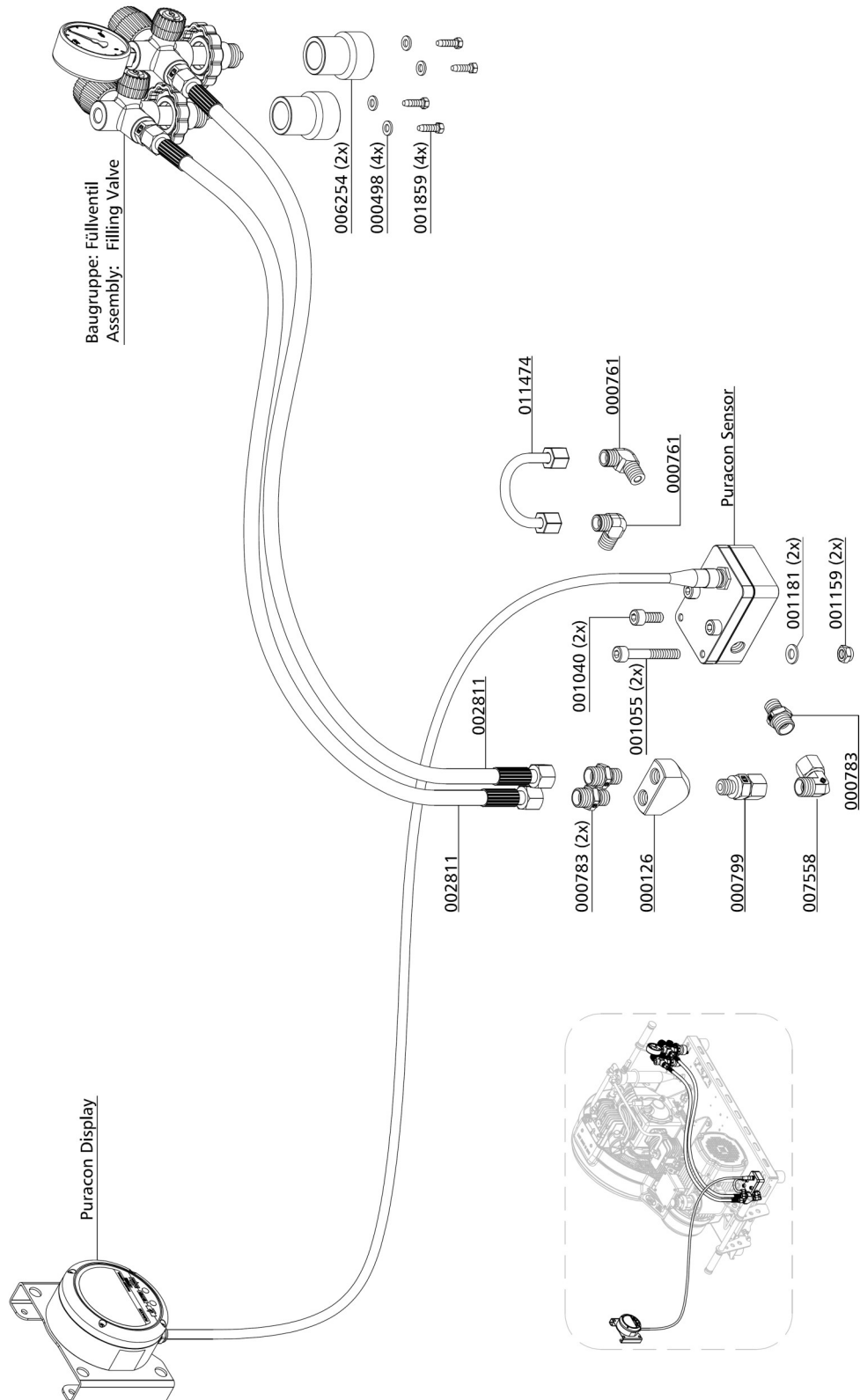

D



SWITCH OVER DEVICE 200/300 BAR

D

SWITCH OVER DEVICE 200/300BAR

Operation:

300 bar

The pressure selector spindle (1) should be screwed fully in clockwise.

200 bar

The pressure selector spindle (1) should be screwed fully out anti clockwise.

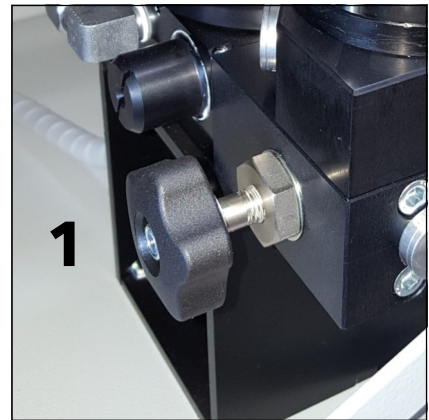

Switch over Device



ATTENTION

Operate 200/300bar pressure selector spindle (1) only if filterhousing has been vented by using the drainage valve (2).

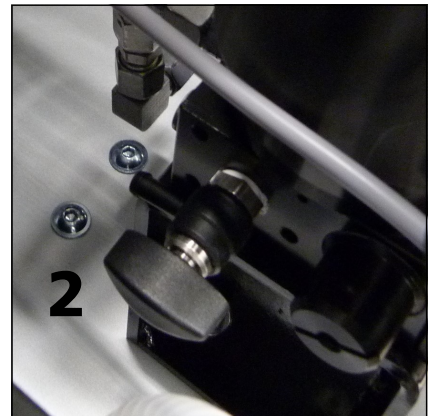

Drain Valve at Final Filter Tower



SWITCH OVER DEVICE 200/300BAR

Spare Part List

Best.-Nr. / Order No.	Benennung	Description
000391	Usit-Ring	Seal Ring U-Sit
000498	U-Scheibe A6	Washer
000796	Verschraubung WE10L	Elbow Connection
001001	Zylinderschraube M6x75mm	Allen Bolt
001058	Zylinderschraube M8x70mm	Allen Bolt
001156	Stopfmutter M6	Lock Nut
001244	O-Ring Ø16x2mm	O-Ring, flange safety valve
001770	O-Ring, Düsenschraube Ø7x1,5mm	O-Ring Inlet Jet
001859	Befestigungsschraube Ø5,5x19	Fixing Bolt V-Belt Cover
002354	O-Ring Ø8x1,5mm	O-Ring
002811	Hochdruckschlauch	HP-Hose
005173	Spindel Druckumschaltung	Spindle, switch over device
005174	Dichtkegel Druckumschaltung	Conical nipple,switch o.device
006254	Füllventilhalter	Filling Valve Holder
006304	Umschaltventilkörper	Housing
006305	Hohlschraube	Banjo Bolt
006306	Sterngriff	Star Shaped Grip
006307	Verbindungsniessel	Nozzle

D

SWITCH OVER DEVICE 200/300BAR

Detailed View

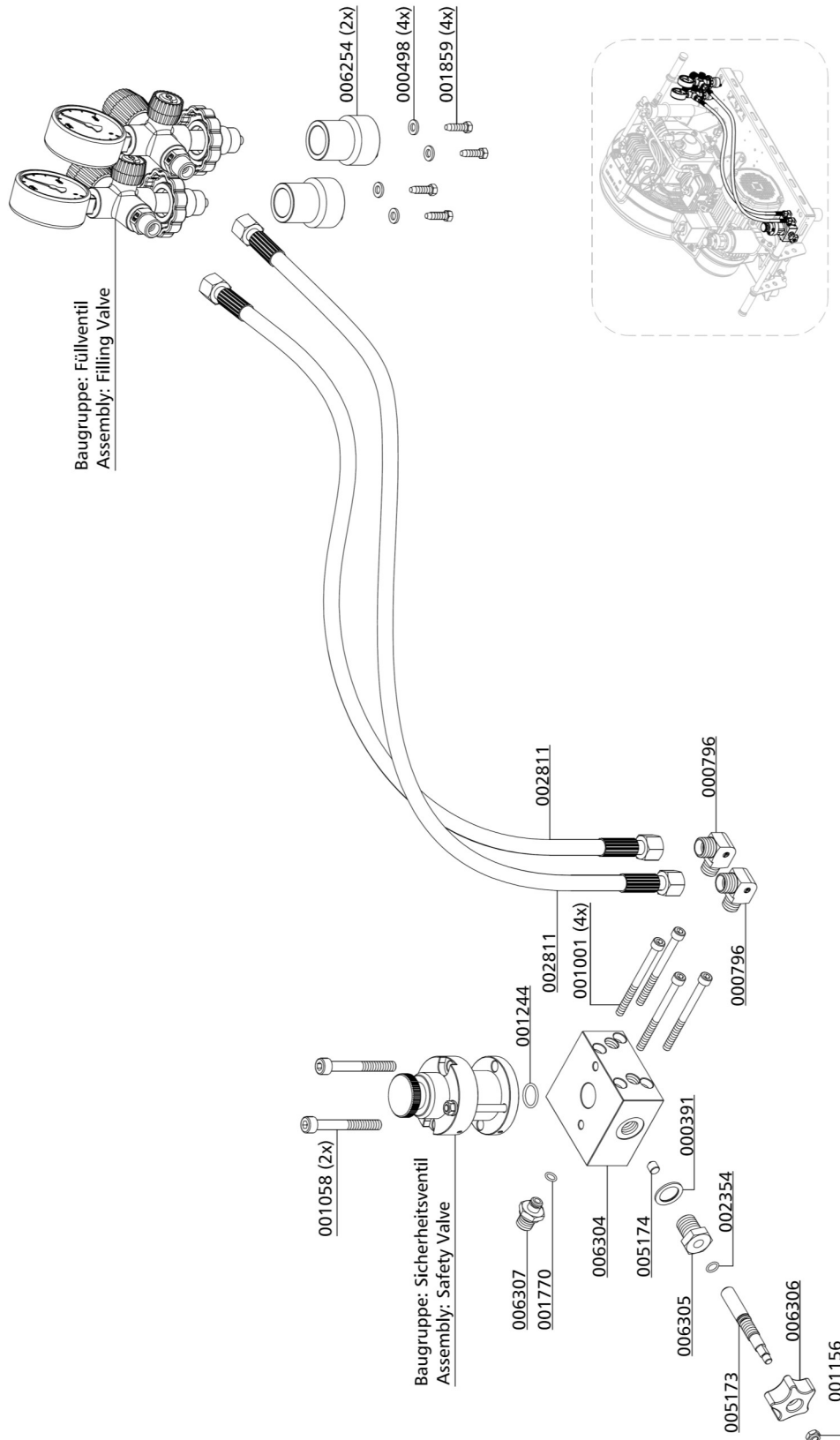

D



**FINAL FILTER SEPARATOR
0.98 LTR**

D



FINAL FILTER SEPARATOR 0.98 LTR

Filter Housing 0.98 ltr

Inside the filter housing a jet blows air on to the wall of the housing. Condensation water and oil are led by centrifugal force to the bottom of the housing. Air flows through the mole carbon filter cartridge, which purifies the air from residual moisture and odours. The manual condensate drain valve needs to be opened if a drain is necessary and before filter cartridge change.

Filter Cartridge 0.98 ltr

The high-pressure compressor is equipped with an integrated breathing air purification system. Air is compressed up to 350 bar, dried and odour- and tasteless purified. Oil residues are bounded. The breathing air filter cartridge consists of a molecular sieve and activated-carbon filter.

Cartridge capacity: approx. 0.98.ltr

All breathing air filter cartridges are vacuum sealed.

We recommend unpacking the filter cartridges just before installation. Filter cartridges which are exposed too long could be saturated with moisture and become unusable.

Maintenance Intervals

The life of the filter cardridge is substantially depend on the operating temperature, from the state of wear of the compressor, of the filter size and the operating pressure.

We recommend to monitor the state of the filter.

D



FINAL FILTER SEPARATOR 0.98 LTR

Spare Part List

Best.-Nr. / Order No.	Benennung	Description
000506	Druckfeder Druckhalteventil	Spring PMV
000508	USIT Ring	Gasket Ring U-Sit
000516	Nutring, DHRV	Seal Ring PMV
000517	Druckfeder, DHRV	Coil Spring PMV
000518	U-Scheibe M5	Washer, M5, brass
000519	Dichtkappe, DHRV	Plastic Seal Piston PMV
000738	Gerade Verschraubung	Straight Connection
000783	Gerade Verschraubung	Straight Connection
000837	Verschlussstopfen	Plug
000941	Madenschraube	Worm Screw
001039	Zylinderschraube	Allen Bolt
001159	Stopfmutter	Lock Nut M8
001181	U-Scheibe A8	Washer A8
001742	Druckstift , DHRV	Pressure Pin
001744	Einstellschraube, DHRV	Adjusting Bolt
001769	O-Ring, Filtergehäuse	O-Ring Filter Housing LW 100
001788	Federdruckstück	Spring Adapter
001819	O-Ring, Filterpatrone-Nippel	O-Ring, Filter cartrid. nipple
001825	O-Ring, Filterpatrone	O-Ring, filter cartridge
003006	O-Ring, DHV	O-Ring, PMV
003077	Entwässerungsventil R1/4 AG, konisch	Drain Valve R1/4 male
008347	Alu-Schraubadapter (MC-Version)	Screw Adapter
008348	Düsenrohr Hochdruckfilter	Nozzle Tube
009657	Filterschlüssel	Filter key
010572	Drallscheibe	Swirl Disk
010573	Umlenkung Einlassluftstrom	Deflection Inlet Airflow
010576	O-Ring	O-ring 63,5 x 2
010759	Zylinderschrauben M4x12mm	Allen Bolt M4x12mm
011174	Filterpatrone 0,69 Liter	Filter Cartridge 0.69 ltr.
011189	Filterpatrone 0,69 Liter	Filter Cartridge 0,69 ltr.
011536	Haltebügel Filtergehäuse	U-Clamp for Filter Housing

D



FINAL FILTER SEPARATOR 0.98 LTR

Spare Part List

Nicht einzeln lieferbar / not available separatly

Best.-Nr. / Order No.	Benennung	Description
001716	Obere Verschlusschraube Filtergehäuse	Plug Filter Housing
001717	Filtersockel, (Filtergehäuse)	Base Filter Housing
010575	Druckbehälterrohr, Ø95x470mm	Tube Filter Housing Ø95x470mm

D

FINAL FILTER SEPARATOR 2.3 LTR

Spare Part List

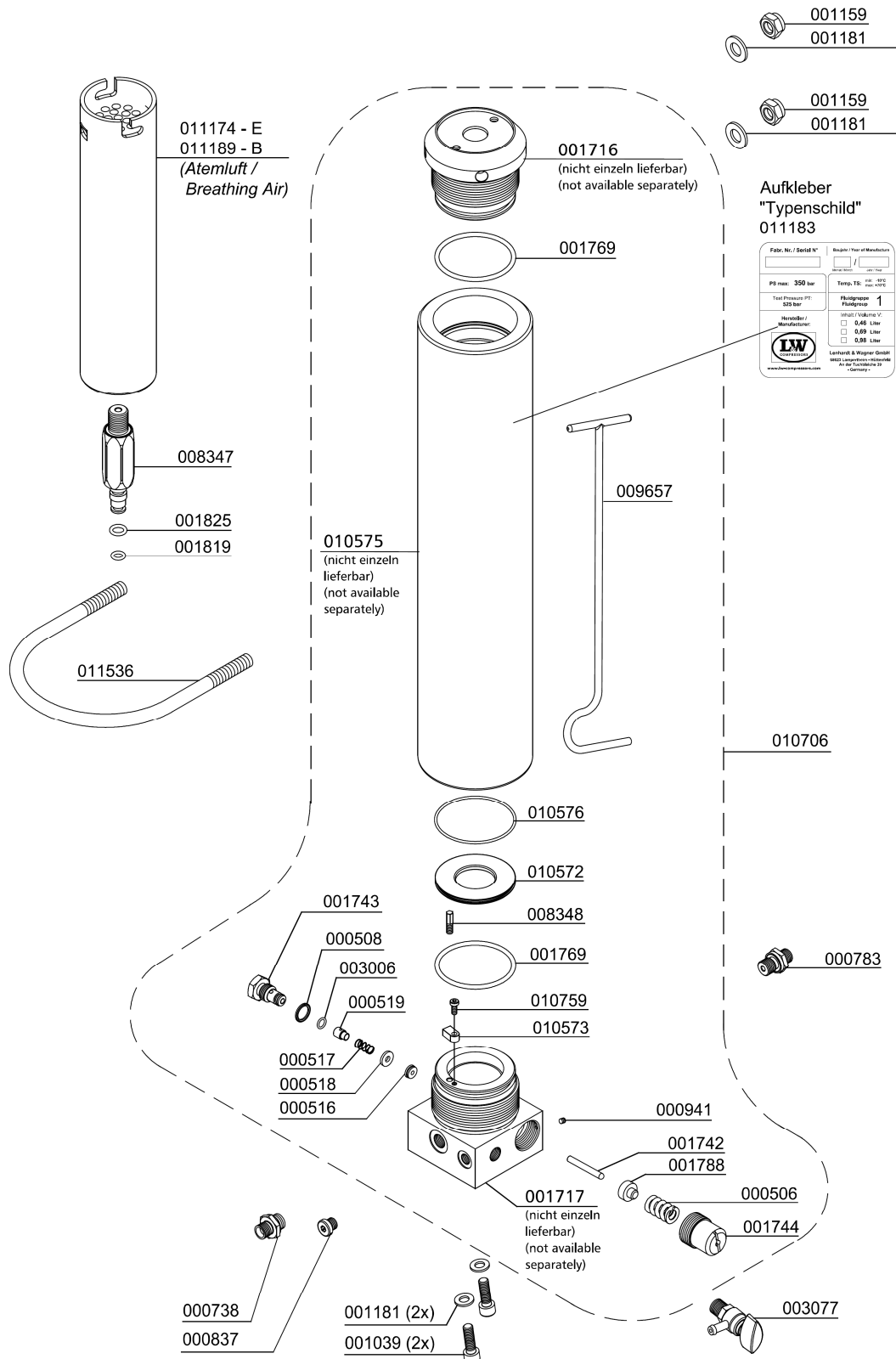

D

MAINTENANCE AND SERVICE

Filter housing

The mole carbon filter housing is installed on the right hand side of the compressor housing.

Inside the filter housing a jet blows air on to the housing wall. Condensation water and oil are led by centrifugal force to the bottom of the housing. Air flows through the mole carbon filter cartridge, which purifies the air from residual moisture and odours.



Fig. Filter housing



Danger

It's not allowed to operate the compressor with empty y, unfilled cartridges. Use only original L&W filter cartridges.

Filter cartridge

P/N	Model	Filtering	Filter Volume
000002	LW 150 E MC	DIN EN 12021 (Breathing air)	0,98 ltr
000002	LW 200 E MC	DIN EN 12021 (Breathing air)	0,98 ltr
000002	LW 250 E MC	DIN EN 12021 (Breathing air)	0,98 ltr

The high-pressure compressor is equipped with an integrated breathing air purification system. Air is compressed up to 330 bar, dried and odour- and tasteless purified. Oil residues are bounded. The breathing air filter cartridge consists of a molecular sieve and activated-carbon filter.

All breathing air filter cartridges are factory vacuum sealed.

We recommend unpacking the filter cartridges just before installation. Filter cartridges which are exposed too long could be saturated with moisture and become unusable.

Maintenance Intervals

Filter cartridges should be changed at the following intervals, at +20°C or more often, depending on humidity and ambient temperature:

- 100 hours for LW 150 E MC
- 75 hours for LW 200 E MC
- 60 hours for LW 250 E MC

MAINTENANCE AND SERVICE

Filter cartridge change

Filter cartridge change as follows:

- Stop the compressor and open carefully the drain valves. Please wait till the filter housing is completely vented; this procedure takes approx. 1 - 2 minutes
- When no air discharges from the condensate release hoses, the pressure vessels are depressurized.
- Remove the end filter cover (Fig. 1 / Fig. 2). Remove the filter cover by using the filter tool. The housing can not be opened when it is still under pressure.
- After opening the housing, pull out the filter cartridge by the catch (Fig. 3).
- Open the packaging of the new filter cartridge and place it into the filter housing (press slightly).
- Screw the filter housing cover in by using the filter tool and turn it back 1/4 turn. This avoids tightening of the cover due to vibration.

The filter cartridge change is now completed.



Note

Ensure that the old filter cartridge is disposed correctly at an approved waste point.



Fig. 1 -Loosen filter housing cover by using the filter tool



Fig. 2 - Remove filter housing cover



Fig. 3 - Pull out the filter cartridge by the catch and insert a new cartridge

MAINTENANCE AND SERVICE

Inlet Filter



Note

Dirty filters make air intake difficult and reduce delivery capacity. Risk of compressor overheating.

A paper dry filter is used for the inlet filter. Check air inlet filter regularly or replace it. Depending on the degree of contamination, the filter inlet can be cleaned by compressed air. Defective air inlet filters should be immediately replaced with a corresponding filter.

Maintenance intervals

We recommend that the filter cartridge should be replaced every 500 working hours (depending on pollution grade).



Inlet Filter



AIR COOLER CONNECTION KIT

D

AIR COOLER CONNECTION KIT

Air cooler connection kit

The Air Cooler Connection Kit provides an easy connection and a simple and time-saving installation or backfitting.

The piping inside the compressor is completely installed. Just disconnect the U-connection at the outside and connect the air cooler according to the connection designation (inlet/outlet).

How to connect the air cooler connection kit.

- Connect the outlet of the air cooler adapter to the inlet of the air cooler.
- Connect the inlet of the air cooler adapter to the outlet of the air cooler.

To operate the unit without air cooler, reinstall the U-connection and the compressor is ready for use.

Connecting hoses

The Air Cooler Connection Kit does not include high pressure hoses. We offer different length and specification. Please ask for details.

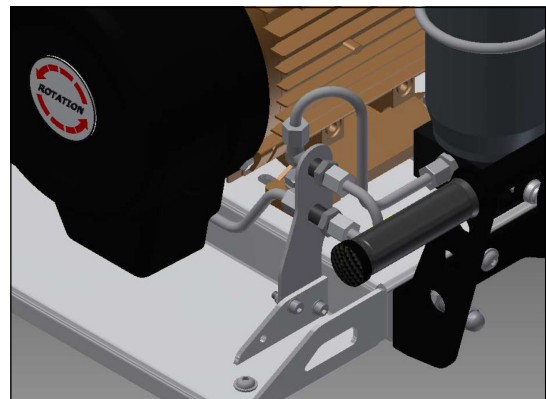

Air cooler connection kit



AIR COOLER CONNECTION KIT

Spare Part List

Best.-Nr. / Order No.	Benennung	Description
000498	U-Scheibe A6	Washer
000899	Schottverschraubung 8L	Bulkhead Fitting 8L
001029	Zylinderschraube M6x20mm	Allen Bolt
001156	Stopfmutter M6	Lock Nut
001176	U-Scheibe A5	Washer
002535	Winkelschottverschraubung	Bulkhead connection
008656	Rohrschelle Ø8mm	P-Clip
009760	Zylinderschraube M5x12mm	Allen Screw
011477	Halblech Schottverschraubungen	Bracket Bulkhead Fitting
011478	Halblech Schottverschraubungen	Bracket Bulkhead Fitting
011479	Rohrleitung Ø8mm, komplett mit M.&S.	Pipe Ø8mm, c/w Nuts and Olives
011480	Rohrleitung Ø8mm, komplett mit M.&S.	Pipe Ø8mm, c/w Nuts and Olives
011481	Rohrleitung Ø8mm, komplett mit M.&S.	Pipe Ø8mm, c/w Nuts and Olives
011482	Rohrleitung Ø8mm, komplett mit M.&S.	Pipe Ø8mm, c/w Nuts and Olives

D

AIR COOLER CONNECTION KIT

Detailed View

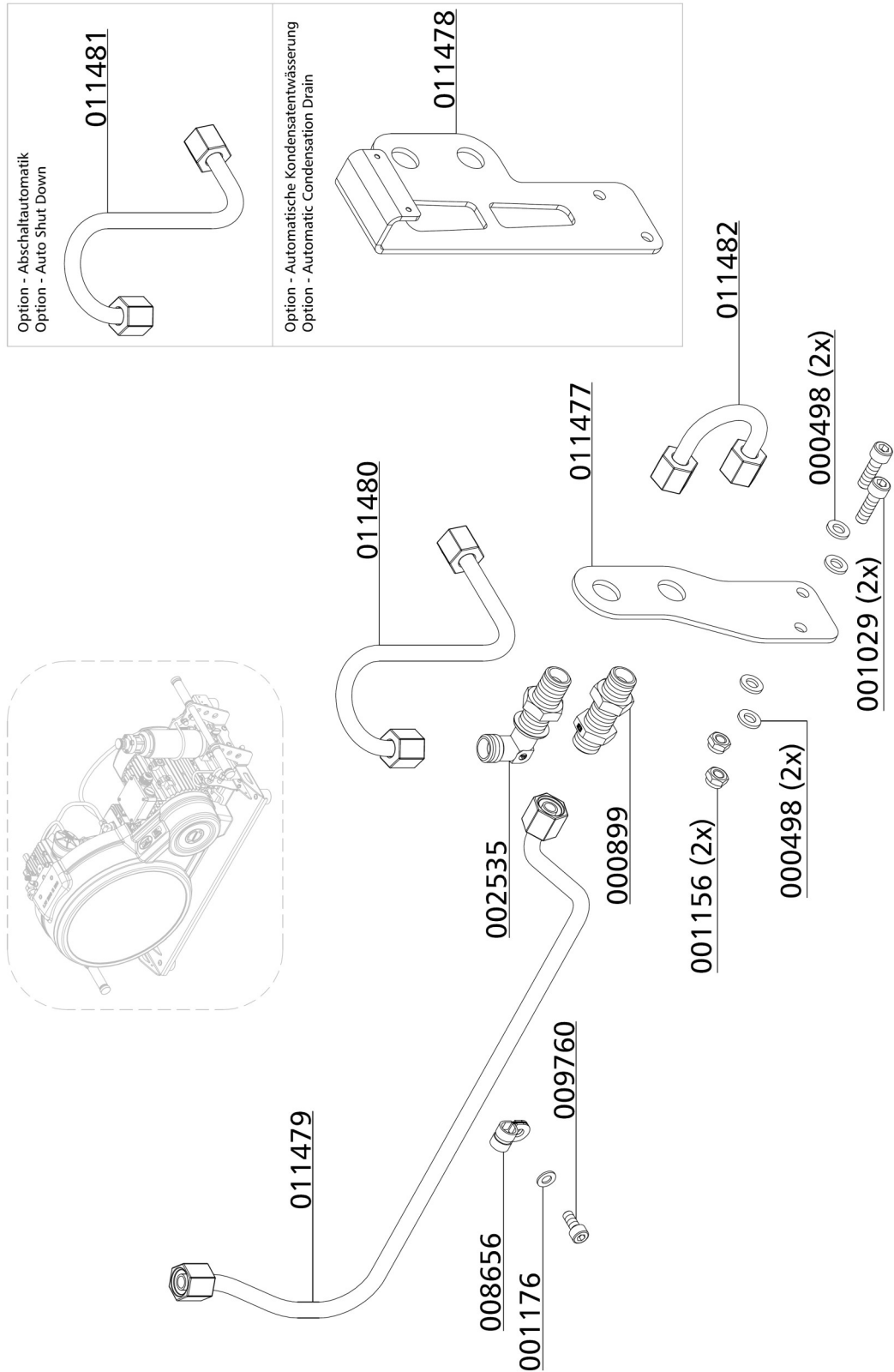

D



WHEEL SET

D



WHEEL SET

Spare Part List

Best.-Nr. / Order No.	Benennung	Description
000498	U-Scheibe A6	Washer A6
000967	Zylinderschraube M10x30mm	Allen Bolt
001066	Zylinderschraube M8x120mm	Allen Bolt
001156	Stopfmutter M6	Lock Nut
001159	Stopfmutter M8	Lock Nut
001164	Stopfmutter M10	Lock Nut
001181	U-Scheibe A8	Washer
001186	U-Scheibe A10	Washer
001713	Standfuß, Gummipuffer	Rubber Stand
001828	U-Scheibe A10,5	Washer
005842	Linsenflanschschraube	Flange Button Head Screw
008419	Linsenflanschschraube M8x25	Flange Button Head Screw
008655	Linsenflanschschraube	Flange Button Head Screw
011366	Lenkrolle Ø100x32 mm	Swivel Castor Wheel Ø100x32 mm
011384	Distanzstück für Gummifuß / Radsatz	Spacer, Ø50mm, anodized black
011397	Satz Haltebleche mit Rohrbügel	Stirrup and Brackets

D



ATTACHMENT

E

Lenhardt & Wagner GmbH

**An der Tuchbleiche 39
D-68623 Lampertheim – Hüttenfeld**

www.lw-compressors.com



Operating Instruction

Safety valve

Typ:

SiV2 BKZ TÜV.SV.19-1140.5.G.V.P CE 0091 AlMgSi1 F31 1100* Lenhardt & Wagner

Set pressure:	see mark (hand wheel on top of valve)
Maximum outflow:	Set pressure 100-159 bar: 750 l / min Set pressure 160-350 bar: 1.100 l / min
Suitable media:	Media-resistant, non-corrosive gases

The safety valve is used for protection of pressurized components, eg pipelines, pressure vessels, or the compressor itself.

The hand wheel on the top of the safety valve is marked with the adjusted set pressure.



- 1) *Identification of set pressure*
- 2) *Seal*
- 3) *Fixing screws¹*
- 4) *Venting screw (hand wheel)*
- 5) *Identification serial number*
- 6) *Socket for safety valve*

Safety valve with socket

¹ The fixing screws M8 must be strength class 8.8 and meet the requirements of Merkblatt AD 2000 leaflet W7. Shaft length 70mm.

In order to prevent manipulation of the set pressure, all safety valves are factory fitted with a seal.

A safety valve on which the seal has been removed, must be returned to the manufacturer for repair / adjustment before further use.

In addition, the safety valve has a venting device (hand wheel).

When rotated clockwise, the safety valve and the filter housing of the final stage are completely vented.

During normal operation, the screw is unscrewed to the upper stop anticlockwise; an integrated safety ring prevents the screw from being removed.

If a safety valve blows off, the system must be switched off immediately and the cause of the error, investigated.

There are two possible reasons:

1. The safety valve is defective and blows off before the set pressure.

In this case the safety valve should be submitted immediately to the manufacturer for repair or replaced with a new one.

2. The safety valve opens properly, the problem is on the system.

A constant blowing of the safety valve is not permitted, the sealing seat of the valve can be damaged. The error on the system must be detected and repaired before further filling operations.

The safety valve may only be used if it is ensured that the maximum flowrate of the system does not exceed the blow-off rate of the safety valve.

The safety valve may only be used with the approved media.

Repair work on compressors must only be performed by trained personnel.

Dismantling of the safety valve

Ensure that on the safety valve is no pressure.

Loosen and remove the two M8 fixing bolts with a 6 mm Allen key.

The safety valve can now be removed by turning and simultaneously pulling out of the socket.

Mounting

1. Clean the safety valve socket.

2. Oil the insert pin of the safety valve including the O-ring with 1 to 2 drops of oil.

3. Press the safety valve pin complete into the socket.

4. Fasten the safety valve with the two 8 mm allen screws into the socket

(Tightening torque: 10 Nm)

5. Screw the venting screw (hand wheel) anticlockwise to its upper limit.

6. Start the System (Compressor), check installation for leaks and proper function.

Manufacturer: Lenhardt & Wagner GmbH
An der Tuchbleiche 39
D-68623 Lampertheim – Hüttenfeld

Contact: E-Mail: service@lw-compressors.com
Web: www.lw-compressors.com
Tel.: +49 (0) 6256 – 85880 0
Fax: +49 (0) 6256 – 85880 14

Note:

Only use safety valves which are in a technically perfect condition, for its intended purpose, safety and danger awareness, in compliance with the operating instructions!
Faults which could affect safety must be rectified immediately!

Notes:

- The safety valve must be installed directly on the protected pressure vessel and / or the plant.
 - The safety valve must be installed in an upright position.
 - The flow area of the port must be greater than the valve opening.
 - Protect valve against splashes
-

Maintenance:

- In accordance with current Pressure Equipment Directives, the safety valve must be periodically checked for operation and reliability.
- Refill annually lubricating oil:
Oil filling position:
Hole on the spacer (see arrow, Figure 1)
- Oil quantity: 5-10 drops



Figure 1: Position for oil refill

To be used lubricating oil for the safety valve: L&W Article N°. 008500



INFORMATION ON THE
SERVICE LIFE OF
L&W HIGH PRESSURE HOSES





CONTENTS

Testing hose lines	
Testing hose lines	3
Testing after assembly and before commissioning	3
Recurring test	4
Procedure for hose lines found to be "defective"	4
Test intervals	4
Persons qualified to test hose lines	5
 Maintenance	
Replacing hose lines	6
Immediate replacement of hose lines	6
 Service life	
Service life of L&W high pressure hoses	7
 Storage	
Storing hose lines	8
 Annex	
Scope of testing, test criteria	10 - 11



TESTING HOSE LINES

Testing hose lines

An essential factor in ensuring operational safety when handling L&W compressors is the proper testing of the hose lines used.

Tests are necessary:

- After assembly and before commissioning the hose line.
- After accidents, changes (modifications) to the compressor system, longer periods of non-use and damage due to, for example, collisions or natural phenomena (extraordinary test).
- After carrying out repair work on the compressor system that could compromise safety.
- Recurrently at fixed, regular intervals.

The proprietor must determine the type, scope and deadlines for the tests according to his or her individual operating conditions and on the basis of a risk assessment. **The specifications and recommendations of the manufacturer must be observed.** The specifications made regarding type, scope and deadlines (as well as the replacement intervals) must be documented in writing as occupational health and safety measures.

The results of the tests must also be recorded, e.g. together with the test report of the machine, and kept at least until the next test.

The above-mentioned tests may only be carried out by persons who are qualified to do so and who are authorized by the company (employer).

Testing after assembly and before commissioning

In the test after assembly and before commissioning, factors relating to assembly or factors that can only be evaluated on the fully assembled machine must be assessed.

The assembled hose lines must also be assessed.

Some test points can already be assessed during a visual inspection when the machine is switched off.

An overview of the recommended scope of testing for a visual inspection of hose lines is given in the appendix.

Further test points included in the test of hose lines before commissioning, require a functional test with the machine running.

A recommendation for the scope of testing is given in the appendix.



TESTING HOSE LINES

Recurring test

Since hose lines are subject to influences that cause damage during operation and can lead to dangerous situations, they must be tested recurrently at fixed intervals. The aim of recurring tests is to detect and repair damage in good time.

The objective is to ensure that the system remains in a safe condition.

Procedure for hose lines found to be "defective"

If defects are found during the testing of the hose line that impair the safe condition of the work equipment, these must be rectified immediately. If this is not possible, suitable measures must be taken to ensure that the machine cannot be used further before it is repaired. Defective hose lines must be replaced before the machine can be used further.

It is not permitted to repair or reassemble damaged hose lines with old, previously used parts!

If several hose lines are replaced at the same time, precautions must be taken to prevent mix-ups of the connections or the installation points.

Test intervals

Deadlines for the recurring tests of the hose lines should already be set before commissioning.

Otherwise, there is a risk that work equipment will continue to be used or operated for too long without being tested.

The intervals between the recurring tests must be selected in such a way that deviations from the safe operating condition of work equipment can be detected and eliminated in good time.

The intervals for recurring tests specified here are guidelines and based on experience. Shorter test intervals may have to be specified on the basis of the risk assessment; special operating conditions; or according to the manufacturer's specific instructions in the machine operating manual. Longer test intervals may also be specified, provided that this is justifiable and tenable from a safety point of view. The determination of the test intervals should be documented.

Type of test	Recommended test intervals
Visual inspection	Before commissioning the system
Functional test	Annually with previous visual inspection



Persons qualified to test hose lines

A qualified person is a person who, through his or her professional training, professional experience and recent professional activity, has the necessary specialist knowledge required for testing work equipment - in this case for testing hose lines.

These requirements are defined in the Technical Rules for Industrial Safety TRBS 1203

"Qualified persons - general requirements" fulfilled if:

- the qualified person has completed a professional training that enables his or her professional knowledge to be determined in a comprehensible manner, i.e. based on professional qualifications or comparable evidence. For the testing of hose lines, the person concerned must have completed a technical professional training or another technical qualification sufficient for the intended testing tasks. The object is to guarantee that the tests will be carried out properly.
- proof of practical use at work of the equipment to be tested as well as the associated professional experience is provided. The qualified person must be sufficiently familiar with the conditions that demand the performance of tests, such as the result of the risk assessment or observations during the working day.
- there is proof of recent professional activity in the area of the upcoming tests and appropriate further training. The qualified person must also have gained experience with regard to the tests to be performed or comparable tests. He or she must also have knowledge of the state of the art with regard to the work equipment or components to be tested as well as the hazards to be considered. This also includes knowledge of the relevant technical regulations and the updating of this knowledge, e.g. through participation in training courses/instruction.

The qualified person is not subject to any technical instruction during the course of his or her testing activity and must not be disadvantaged because of this.

Experts who have carried out tests on the hose lines up to now and who meet the three criteria mentioned above and who have familiarized themselves with the contents of the German Ordinance on Industrial Safety and Health and the changes associated with it are also considered qualified persons to whom the tests can continue to be assigned.

See also:

- ⇒ § 2 para. 7 of the German Ordinance on Industrial Safety and Health,
- ⇒ Technical Rules for Operational Safety TRBS 1203.



Replacing hose lines

As a general rule, even when stored properly and subjected to permissible stress during use, all hose lines are subject to natural aging, which changes the material and composite properties and reduces the performance of the hose lines.

This limits the service life of a hose line and the operator must ensure that hose lines are replaced at appropriate intervals.

Immediate replacement of hose lines

Hose lines must be replaced immediately in the event of the following defects:

- External visible damage to the hose line or fittings.
- Internal damage to the tube or the reinforcement.
- Leakage from the hose line or the fittings.
- Deformation of the hose line or the fittings.



Service life of L&W high pressure hoses

When determining the service life or the replacement interval of the individual hose lines, the concrete specifications and recommendations of the hose line or machine manufacturer must be observed. Furthermore, empirical values resulting from previous tests done under the prevailing operating conditions on site are also relevant.

Guideline values for recommended replacement intervals of hose lines which have proven themselves in practice are summarized below.

Hose line requirements	Recommended replacement intervals
Standard requirements	6 years (Service life including a maximum of 2 years storage time)
Increased requirements, e.g. due to - increased operating time, e.g. multi-shift operation, or short machine or pressure pulse cycle times - strong external and internal influences (due to the medium), which greatly reduce the service life of the hose line	2 years (service life)

The guideline given above for a replacement interval of six years for hose lines meeting normal requirements includes a maximum storage period of two years. The guideline value of two years for hose lines meeting increased requirements represents the maximum permissible service life.

A prolongation of the guideline values given above for replacement intervals is possible if

- appropriate test values and empirical values are available from the operator of the machine which permit safe continued use beyond the recommended maximum service period,
- a hazard or risk assessment, documented in writing, has been carried out by the operator, which also takes into account protective measures in the event of failure of hose lines, and
- tests for safe working conditions are carried out by qualified persons at appropriately set, if necessary reduced, intervals.

It must be ensured that the prolongation of the replacement intervals does not result in a dangerous situation that could injure employees or other persons.

If hose lines fail during operation or if damage or defects are frequently detected during the recurring tests, then, in addition to investigating the causes, the test and replacement intervals must be shortened.



STORAGE

Storing hose lines

When storing hose lines, storage conditions must be aimed at minimizing the natural aging that occurs over time and the associated change in material and composite properties.

For this purpose, the following information must be provided:

- Store in a cool, dry and low-dust place.
Low-dust storage can be achieved, for example, by wrapping the hoses in plastic film.
- Avoid direct sun or UV radiation.
- Shield from nearby heat sources.
- Avoid storage temperatures below -10 °C for elastomers.
- Do not use ozone-generating light fittings or electrical devices that may produce sparks in the immediate vicinity.
(Ozone-generating light fittings are, for example, fluorescent light sources, mercury vapor lamps).

The most favorable storage conditions are temperatures between +15 °C and +25 °C, as well as a relative humidity below 65 %.

During storage, hose lines must not come into contact with substances that could cause damage, e.g. acids, alkalis, solvents. Penetration of ozone or other harmful air constituents can be prevented by sealing the ends or by wrapping the hoses in plastic film. They must be stored flat and free of tension.

The storage period for hose lines should not exceed two years.



ANNEX



ANNEX SCOPE OF TESTING; TEST CRITERIA

Recommended scope of testing "visual inspection" (before initial commissioning or recommissioning)

- Is all user information required for safe operation of the system available (e.g. flow chart, operating instructions)?
- Do the hose lines comply with the flow chart or parts list?
- Are there protective measures in place, such as pressure relief valves, for cases of unusually high pressure pulses or pressure amplifications?
- Are the hose lines marked with the name or abbreviation of the manufacturer, maximum permissible operating pressure, nominal diameter, quarter/year of manufacture?
- Are the hose lines installed in such a way that, in accordance with DIN 20 066
 - the natural position does not hinder movement?
 - turning or twisting of the hose is prevented, likewise tensile load caused by a line that is too short and a bending radii that is too small?
 - the hose is routed via a kink protector (if necessary on the connecting element)?
 - sufficient clearance prevents external mechanical influences or abrasion on the edges?
 - hose bridges prevent damage being caused by driving over the hose line?
 - hose guides (such as hose saddles and sufficiently wide hose brackets) protect loosely laid hose lines and
 - a heat shield protects against high temperature exposure?
- Are suitable protective measures, such as fixtures, safety gear or shielding provided for hose lines that, in the event of failure, pose a risk of whipping?
A risk is to be assumed if persons are generally present in the immediate vicinity of the hose lines, for example.
- Do the hose lines of newly commissioned or re-commissioned machines already show signs of damage?
- Are the installed hose lines still within the storage/use period recommended by the relevant manufacturer?
- Are the hose lines free of paint?
- Are the hose lines free of chafe marks?
- Does the operating manual contain information on test intervals? If so, what?

Note:

The installed hose lines should not be made from used hoses or used press fittings that have already been in use as part of a hose assembly!



ANNEX SCOPE OF TESTING; TEST CRITERIA

Recommended scope of testing "Functional test" (before initial or recommissioning)

Note:

Visual inspection must be carried out before the functional test

- All parts of the system must be tested at least at the maximum working pressure that could be achieved taking into account all intended applications:
 - Are the hose lines and connecting elements free of leakage?
 - Have all hose lines withstood the pressure?

Note:

The installed hose lines should not be made from used hoses or used press fittings which have already been in use as part of a hose assembly!