



CHAPTER OVERVIEW

Operating Instructions

A

ECC - Electronic Compressor Control (if equipped).....

B

Spare Parts Lists

C

Options (if equipped).....

D

Attachment

E

Manufacturer in terms of 97/23/EC

The full name and address of the manufacturer is:

Lenhardt & Wagner GmbH

An der Tuchbleiche 39

68623 Hüttenfeld / Germany

Phone: +49 (0) 62 56 - 85 88 0 - 0

Fax: +49 (0) 62 56 - 85 88 0 - 14

E-Mail: service@lw-compressors.com

Internet: www.lw-compressors.com





SERVICE INFORMATION / WARRANTY

Compressor information

Type designation

Serial number

Date of construction

Purchase information

Purchase date

First commissioned on

Warranty period

Dealer's stamp

Warranty

L&W will uphold warranty claims made during a period of 12 months from the invoice date.

If the compressor was purchased from an official L&W dealer, the date on the dealer's invoice is valid. Warranty claims can only be made on presentation of the original invoice.

Should verifiably defective parts have been delivered, we will decide to either replace the parts or repair them. The resulting transport and assembly costs will be invoiced.

No reduction of the purchase price or changes to the contract can be made. The parts for which a claim is being made should be kept safe by the purchaser and, when requested, sent to us at their cost. Replaced parts become the property of L&W. If maintenance work is carried out without our knowledge or permission by the purchaser or a third party, we are absolved from any liability for warranty claims. As a matter of principle, warranty claims can only be made by the initial purchaser.

Operating Instructions

Breathing Air Compressor

LW 1300 E

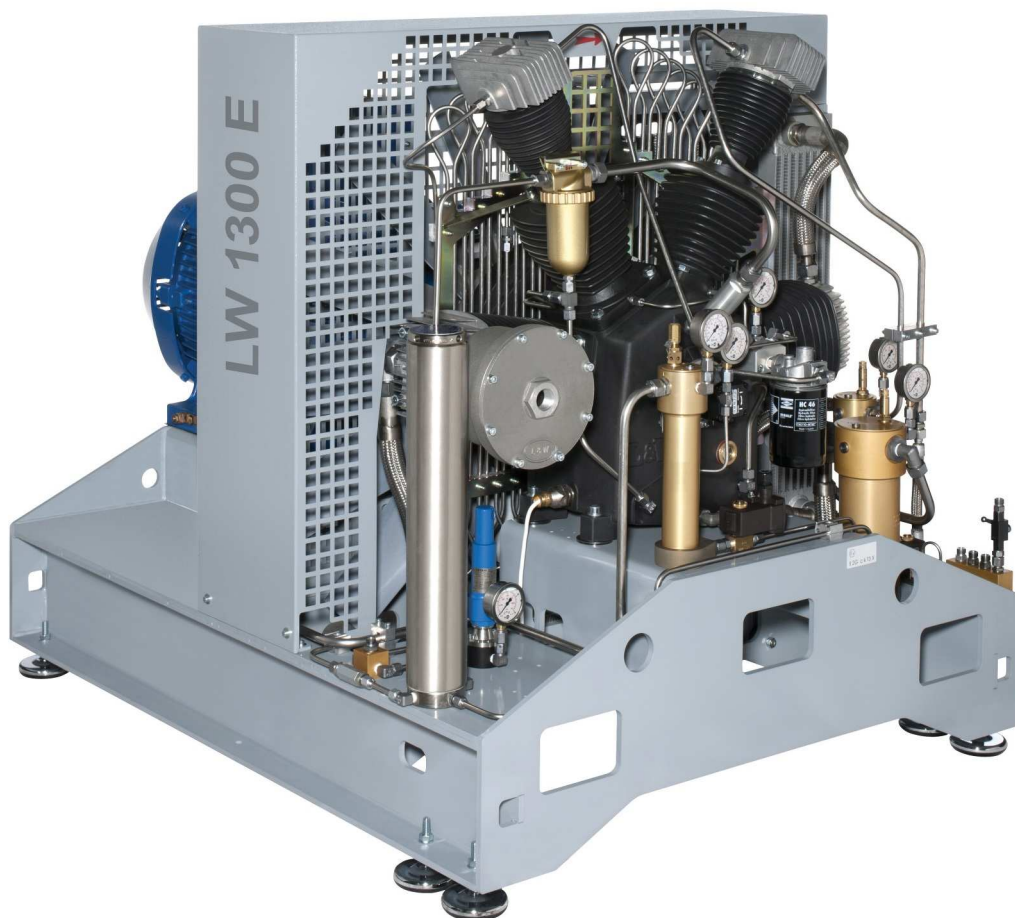



TABLE OF CONTENTS

General Information and Technical Data

General Information / Description of Warning Symbols	4
Scope of Delivery	5
Technical Data	6
Unit Assembly	7
Switchboard	8
Flow chart	9

Safety Precautions

Intended Use / Operators	11
Safety instructions on the unit	12
General Safety Precautions	13
Unit customised safety notices	14
Maintenance instructions	15
Transportation instructions / Safety regulations	16

Installation

Installation in closed rooms	18
Dimensions	19
Minimum distances	20
Ventilation	21
Electrical Installation	22 - 23

Operation

Important operation instructions	25
First commissioning	26 - 28
Daily commissioning	29
Filling procedure	30
Switch off the compressor	31
Interstage pressure gauges	32
Oil pressure gauge and oil distributor block gauge	33
Oil pressure monitoring	34

Remedying faults	36 - 39
-------------------------------	---------

A



TABLE OF CONTENTS

Maintenance and Service

Service, Repair and Maintenance	41
Maintenance Lists / Maintenance Intervals	42 - 45
Service Kits	46
Compressor lubrication / Check oil level	47
Oil change	48
Oil sieve change	49
Final pressure switch	50
Automatic condensation dump system	51
Oil / water separators 1st, 2nd and 3rd stage - maintenance	52
Oil / water separator final stage - maintenance	53
Filter element change 0.8ltr filter housing	54
Pneumatic condensate valve - maintenance	55
Filter panel / Filter cartridge	56
Filter cartridge change	57
Filter housing - Maintenance	58
Inlet filters / Inlet filter cartridge change	59
Cylinder heads and valves	60
Important torque rates for bolts	61
Safety valves	62
Pressure maintaining / non return valve	63
Safety valve test	64
Leak test	65
Pressure gas vessel test	66
Maintenance records	67 - 72

Storage

Conservation / storage of the compressor	74
De-conservation, commissioning	74
Transportation instructions / Disposal	75

A

GENERAL INFORMATION

General Information

We strongly recommend reading this manual thoroughly prior to operation and follow all the safety precautions precisely. Damage resulting from any deviation from these instructions is excluded from warranty and liability for this product. Carry out other commissioning steps only if you have fully understood the following contents.

Before commissioning and using the unit, carry out all the essential preliminary work and measures concerning legal regulations and safety. These are described on the following pages of this operation manual.

A

Description of marks and warning signs

The following warning signs are used in this document to identify the corresponding warning notes which require particular attention by the user. The warning signs are defined as follows:



Caution

Indicates an imminently hazardous situation which, if not avoided, could result in serious injury, physical injury or death.



Warning

Indicates a potentially hazardous situation which, if not avoided, could result in physical injury or damage to the product or environment.



Note

Indicates additional information on how to use the unit.



DESCRIPTION

Scope of Delivery

The LW 1300 E is designed for large industrial applications and is therefore a favorite compressor for breathing air requirements. Low speed ensured continuous operation, long service intervals and reduced maintenance costs. The compressor unit comes fully wired with star/delta start system and includes 3x 2.3 litre breathing air filter console for wall mounting. The 4-stage compressor block is mounted on a painted steel frame and allows a working pressure of max. 420 bar (optional). The drive motor is connected to the compressor by a rubber coupling

Versions

Filling pressure versions:

- PN 225 bar
- PN 330 bar

Specifications

- Electro motor
(Standard: 400V, 3 phase, 50Hz)
- Painted steel frame (RAL 7004)
- Inclusive a remote control box for wall mounting
- Main-, Start/Stop- and condensate test buttons, as well as emergency stop switch
- Hour counter
- Automatic condensate drain
- Automatic stop at final pressure
- Oil pressure gauge
- Intermediate pressure gauges
- Oil pressure monitoring c/w auto shut down
- High pressure outlet 10L
- Pressure maintaining and non return valve
- All pistons c/w steel piston rings
- Low pressure oil pump and filter
- Oil- / Water separators in stainless steel
- Safety valves after each stage
- 4 concentric suction/pressure valves
- Filling pressure of your choice (200 or 300 bar)
- Inclusive 3x 2.3 ltr filter console for wall mounting

Options

- Auto start system
- Oil temperature display with auto shut down
- Cylinder head temperature monitoring with auto shut down
- Puracon filter monitoring (Auto shut down also available)
- ECC control in remote control box
- Power cable and plug
- Block heating device
- 420 bar Version
- Special voltages / frequencies on request

DESCRIPTION

Technical Data

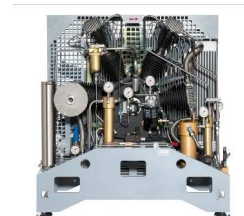

A

Technical Data	LW 1300 E
Capacity [l/min]:	1300
Max. Operating Pressure [bar]:	350 (optional 420)
RPM [min ⁻¹]:	985
Number of Pressure Stages:	4
Cylinder Bore 1st Stage [mm]:	Ø 135
Cylinder Bore 2nd Stage [mm]:	Ø 70
Cylinder Bore 3rd Stage [mm]:	Ø 32
Cylinder Bore 4th Stage [mm]:	Ø 16
Medium:	Compressed Air / Breathing Air
Intake Pressure:	atmospheric
Oil Pressure [bar]:	+3 (+- 0.5)
Oil Capacity [l]:	5.0
Intake Temperature [°C]:	0 < +45
Ambient Temperature [°C]:	+5 < +45
Cooling Air Volume [m ³ /h]:	> 11,100
Voltage:	400 V / 3 phase / 50 Hz
Protection Class Drive Motor:	IP 55
Drive Power [kW]:	37
RPM Motor [min ⁻¹]:	2,890
Start:	Star/Delta
Noise level [dB(A)]:	89 from a distance of 1 m
Dimensions L x W x H [mm]:	1,620 x 1,210 x 1,275
Weight [kg]:	approx. 1000
Content Volume Filter housing [l]:	3 x 2.3

DESCRIPTION

Unit Assembly

A

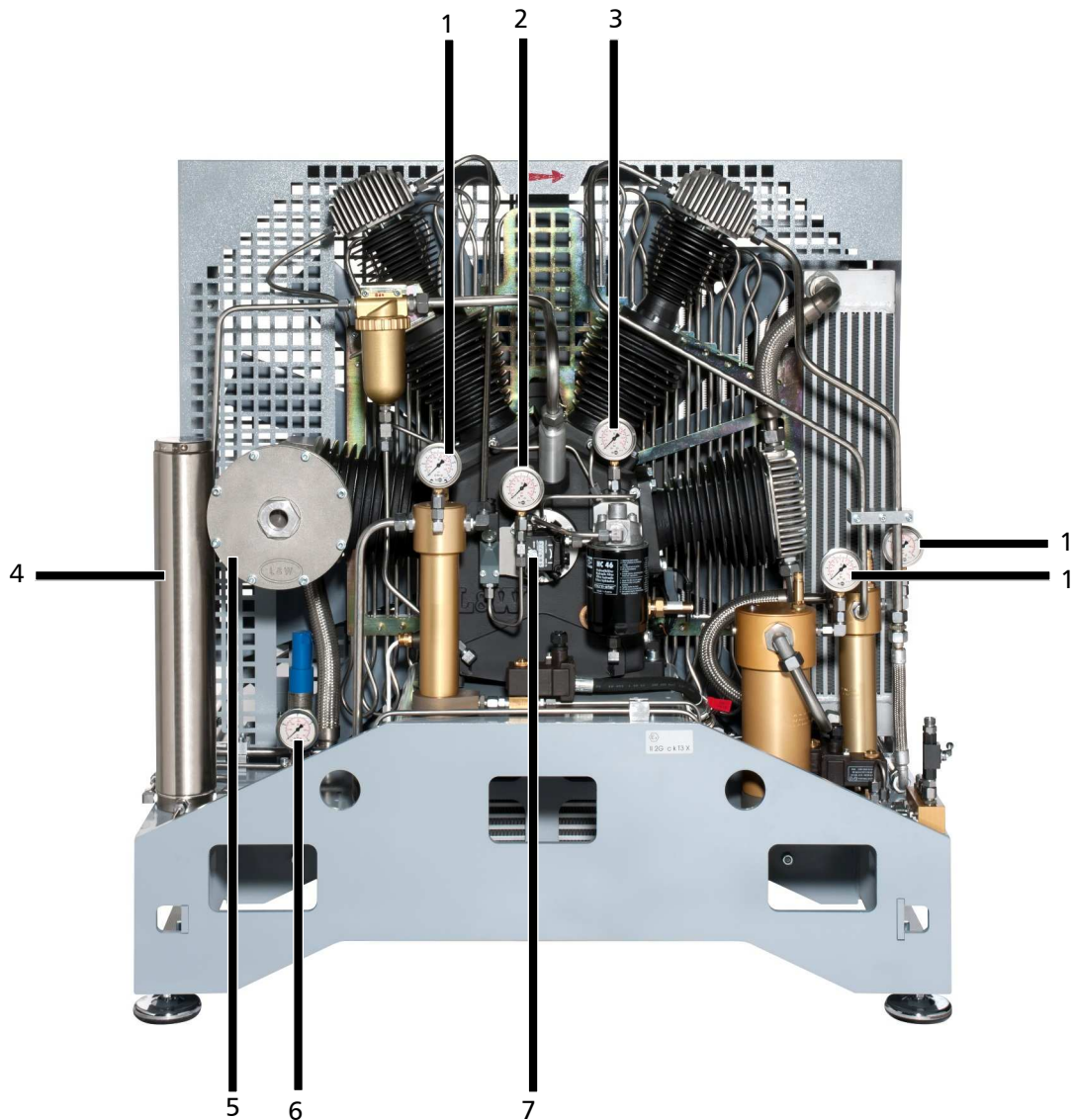

No.	Designation
1	Interstage Pressure Gauge
2	Oil Pressure Gauge
3	Oil Distributor Block Pressure Gauge
4	Final Filter Tower
5	Gastight Inlet Filter Housing
6	Final Pressure Gauge
7	Oil Pump

DESCRIPTION

Switchboard

A



No.	Designation
1	Emergency shut-off switch
2	Hour counter
3	ON button
4	OFF button
5	Drain test button

DESCRIPTION

Fließdiagramm

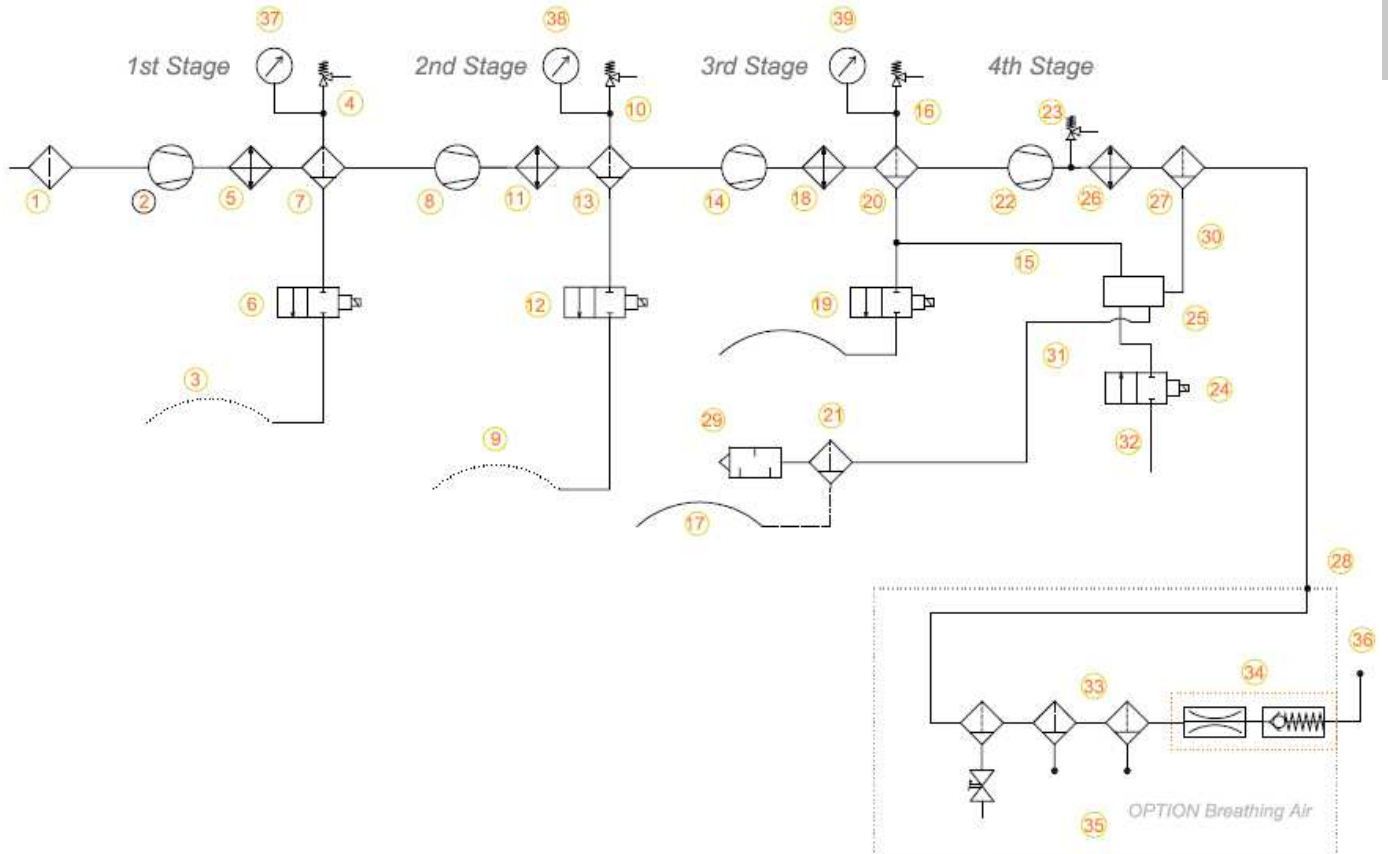

- | | |
|-------------------------------|---|
| 1. Intake Filter | 21. Condensate Separator |
| 2. 1st Compression Stage | 22. 4th Compression Stage |
| 3. Condensate Hose 1st Stage | 23. Safety Valve 4th Stage |
| 4. Safety Valve 1st Stage | 24. Solenoid NC |
| 5. Heat Exchanger | 25. Pneumatic Condensate Valve |
| 6. Solenoid 1st Stage | 26. Heat Exchanger |
| 7. Oil-/Waterseparator | 27. Oil-/Waterseparator 4th Stage |
| 8. 2nd Compression Stage | 28. High Pressure Outlet |
| 9. Condensate Hose 2nd Stage | 29. Silencer |
| 10. Safety Valve 2nd Stage | 30. Condensate Drain Hose 4th Stage |
| 11. Heat Exchanger | 31. Condensate Drain Pipe 3rd Stage |
| 12. Solenoid 2nd Stage | 32. Pressure Drain 3rd Stage |
| 13. Oil-/Waterseparator | 33. Filterhousing 3 x 2.3 Litre |
| 14. 3rd Compression Stage | 34. Pressure Maintaining / Non-return Valve |
| 15. Condensate Hose 3rd Stage | 35. Condensate Drain Valve |
| 16. Safety Valve 3rd Stage | 36. High Pressure Outlet G1/4" |
| 17. Condensate Hose 4th Stage | 37. Pressure Gauge 1st Stage |
| 18. Heat Exchanger | 38. Pressure Gauge 2nd Stage |
| 19. Solenoid 3rd Stage | 39. Pressure Gauge 3rd Stage |
| 20. Oil-/Waterseparator | |



A

SAFETY PRECAUTIONS



SAFETY PRECAUTIONS

Intended Use

Only use the unit in perfect condition for its intended purpose, safety and intended use and observe the operating instructions! In particular disorders that may affect safety have to be eliminated immediately!

Use the unit exclusively for the determined medium (see "Technical Data"). Any other use that is not specified is not authorized. The manufacturer/supplier shall not be liable for any damages resulting from such use. Such risk lies entirely with the user. Authorization for use is also under the condition that the instruction manual is complied with and inspection and maintenance requirements are enforced.

No change and modification to the unit can be made without the written agreement of the manufacturer. The manufacturer is not liable for damage to persons or property resulting from unauthorized modifications.

Operators

Target groups in these instructions;

Operators

Operators are persons who are authorized and briefed for the use of the compressor.

Qualified personnel

Qualified personnel are persons who are entitled to repair, service, modify and maintain the system.



Warning

Only trained personnel are permitted to work on the unit!



Warning

Work on the electrical equipment on / with the machine / unit may only be carried out by qualified electricians.

SAFETY PRECAUTIONS

Safety instructions on the unit

Importance of notes and warning signs that are affixed to the compressor according to the application or its equipment.

A



Warning
High voltage!



Note
Ensure correct direction of rotation!



SAFETY PRECAUTIONS

General Safety Precautions

- Read the Operating Instructions of this product carefully prior to use.
- Strictly follow the instructions. The user must fully understand and strictly observe the instructions. Use the product only for the purposes specified in the intended use section of this document.
- Do not dispose the operating instructions. Ensure that they are retained and appropriately used by the product user.
- Only trained and competent personnel are permitted to use this product.
- Comply with all local and national rules and regulations associated with this product.
- Only trained and competent personnel are permitted to inspect, repair and service the product.
- Only authentic L&W parts and accessories may be used for maintenance work. Otherwise, the proper functioning of the product may be impaired.
- Do not use faulty or incomplete products. Do not modify the product.
- Inform L&W in the event of any product or component fault or failure.
- The quality of the air supply must meet EN 12021 specifications for breathing air.
- Do not use the product in areas prone to explosion or in the presence of flammable gases. The product is not designed for these applications. An explosion might be the result if certain conditions apply.

A



SAFETY PRECAUTIONS

Unit customised safety notices

Organisational measures

- In addition to the instruction manual, observe and comply with universally valid legal and other obligatory regulations regarding accident prevention and environment protection.
- In addition to the instruction manual, provide supplementary instructions for supervision and monitoring duties taking into consideration exceptional factors e.g. with regard to organisation of work, production, personnel employed.
- Supervise personnel's work in accordance with the instruction manual, taking into account safety and danger factors.
- Observe all safety and danger notices on the compressor and check readability and completeness.

Safety instructions operation

- Take measures to ensure that the machine is only taken into operation under safe and functional conditions. Only operate the compressor if all protective and safety equipment, e.g. detachable protective equipment, are provided and in good working order.
- Check the compressor at least once per day for obvious damage and defects. Inform the responsible department / person immediately if anything is not as it should be (including operation performance). Shut down the machine immediately if necessary and lock it.
- In case of malfunction, stop the compressor immediately and lock it. Repair malfunctions immediately.
- If there is a failure in the electric energy supply, shut the machine / unit down immediately.
- Ensure safe and environmentally friendly disposal of consumables and old parts.
- The stipulated hearing protectors must be worn.
- Soundproofing equipment on the compressor has to be activated in safety function during operation.
- When handling with fats, oils and other chemical agents, observe the note for the product-related safety.

A



SAFETY PRECAUTIONS

Maintenance instructions

- Hoses have to be checked by the operator (pressure and visual inspection) at reasonable intervals, even if no safety-related defects have been detected.
- Immediately repair any damage. Escaping compressed air can cause injury.
- Depressurise system and pressure lines before beginning repair work.
- Pressurised air lines must be laid and mounted by qualified personnel. Connections must not be mixed up. Fittings, length and quality of the piping must correspond to requirements.
- Adjustment, maintenance and inspection activities and keep appointments, including information on replacement parts / equipment, prescribed in the operating instructions have to be respected.
- If the machine / equipment is completely off during maintenance and repair work, it must be protected against unexpected restart. Turn off main control device and remove the key and/or display a warning sign on the main switch.
- The machine and especially the connections and fittings should be cleaned from oil, fuel and maintenance products at the beginning of the maintenance / repair. Do not use aggressive cleaning agents. Use fibre-free cleaning cloths.
- Switch off compressor and clean with a slightly damp cloth. Remove dirt from cooling pipes by using a brush.
- After cleaning, examine all pipes for leaks, loose connections, chafing and damage. Immediately eliminate any faults.
- Always retighten any screw connections loosened for maintenance or repair work.
- If it is necessary to remove safety devices for maintenance and repair work, these must be replaced and checked immediately after completion of the maintenance or repair work.
- The electrical equipment of the compressor must be regularly checked. Defects, such as loose screw connections or burnt wires, must be immediately rectified by electrically skilled personnel.
- Only personnel with particular knowledge and experience with pneumatics may carry out work on pneumatic equipment.
- Only personnel with particular knowledge and experience in gas equipment may carry out work on gas equipment.

A



SAFETY PRECAUTIONS

Transportation instructions

- Parts which need to be dismantled for transport purposes must be carefully replaced and secured before taking into operation.
- The transport may only be carried out by trained personnel.
- For transportation, only use lifting devices and equipment with sufficient lifting power.
- Do not stand or work under suspended loads.
- Also separate from minor relocation machinery / system of any external energy supply. Before recommissioning, reconnect the machine to the mains according to regulations.
- When recommissioning, proceed according to the operating instructions..

Safety regulations

- Inspections according to legal and local obligatory regulations regarding accident prevention are carried out by the manufacturer or by authorised expert personnel. No guarantees whatsoever are valid for damage caused or favoured by the non-consideration of these directions for use.

A



A

INSTALLATION

INSTALLATION

Installation in closed rooms



Danger

No operation in explosion-hazard areas.

The unit is not approved for operation in areas prone to explosion.

For installation in closed rooms, observe the following:

- Install the unit horizontally and level. The floor must be vibration-free and capable of taking the load of the system weight.
- The compressor room must be clean, dry, dust free and as cool as possible. Avoid direct exposure to sunlight. If possible, install unit in such a manner that the compressor fan can intake fresh air from outside. Ensure adequate ventilation and exhaust air opening.
- When locating the compressor in rooms of less than 30 m³ space where natural ventilation is not ensured or other systems having high radiation are operating in the same room, measures must be taken to provide artificial ventilation.
- Intake air must be free from noxious gas e.g. smoke, solvent vapours, exhaust fumes etc.
- Observe the specified operating temperature (see "Technical Data")!

A

INSTALLATION

Dimensions

A



Abb. Einbaumaße

INSTALLATION

Minimum distances

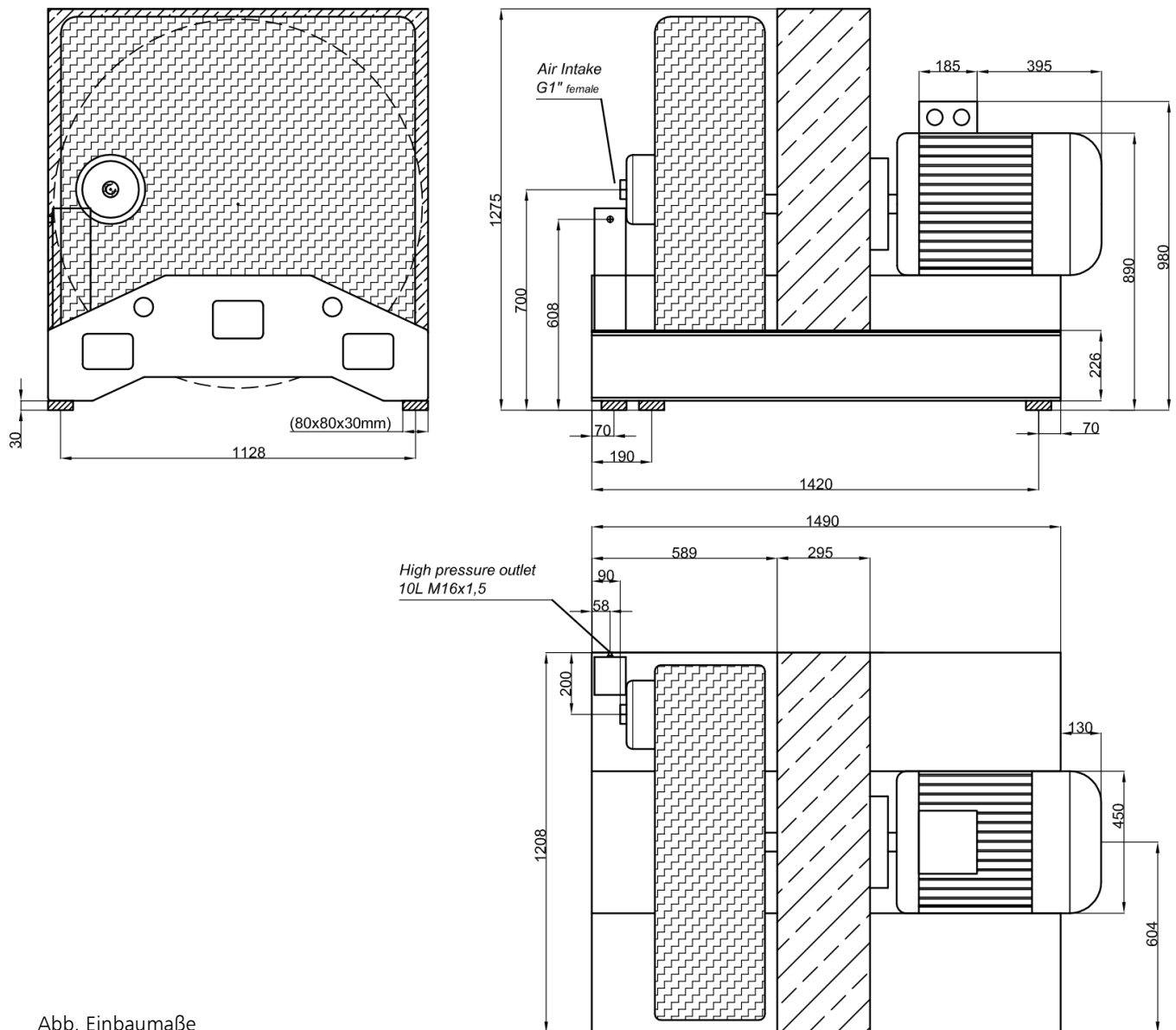

Note

Minimum distances must be adhered!

- Make sure that the compressor always has a sufficient amount of fresh air available.
- To prevent serious damage, ensure that the cooling air flow can flow freely.
- The following minimum distances must be adhered:
Front side min. 1500 mm, sides min. 500 mm, rear side min. 500 mm.
Avoid anything in this area which can restrict the cooling air flow.

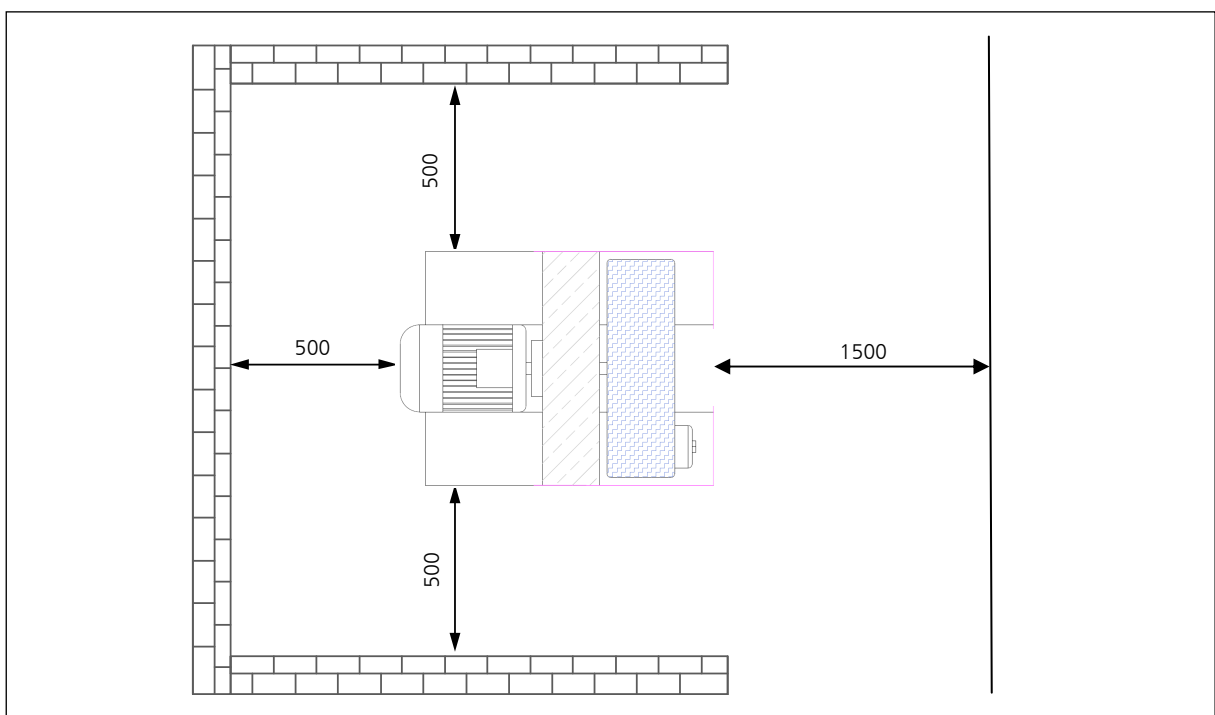

Fig. Minimum distances

INSTALLATION

Ventilation

- Make sure that the compressor always has a sufficient amount of fresh air available for cooling.
- To prevent serious damage, ensure that the cooling air flow can flow freely.
- The necessary cooling air flow can be calculated by using the following formula:
 $300 \times \text{drive power [kW]} = \text{required cooling air flow [m}^3/\text{h]}$
 Example 11kW motor: $300 \times 11\text{kW} = 3300 \text{ m}^3/\text{h} = \text{required cooling air flow.}$
- The fan capacity for fresh air and warm air must meet at least the required cooling air flow.
 The fans must have the same capacity.

A

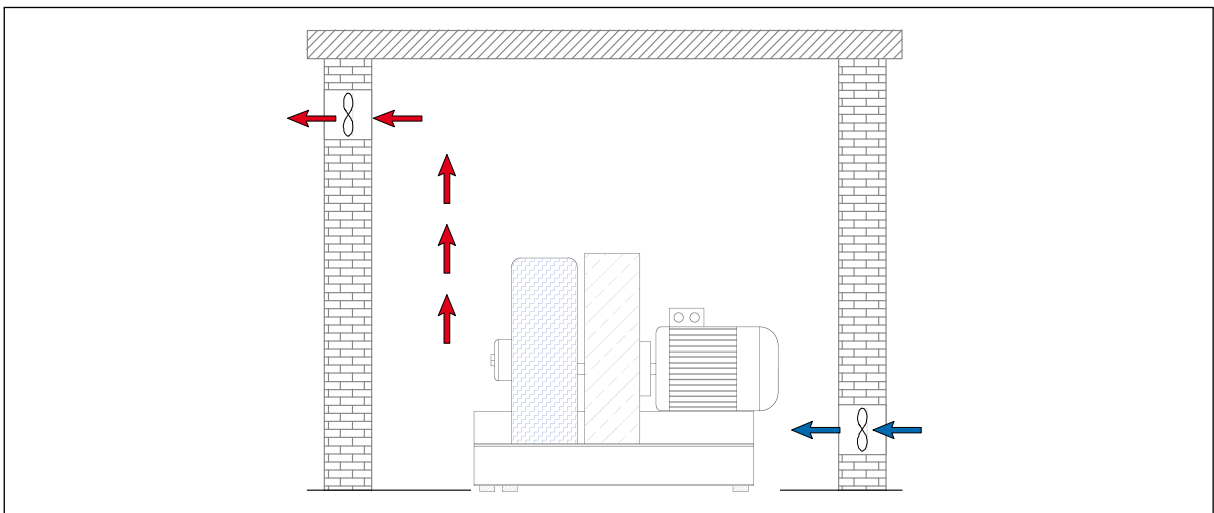

Fig. Ventilation through facade

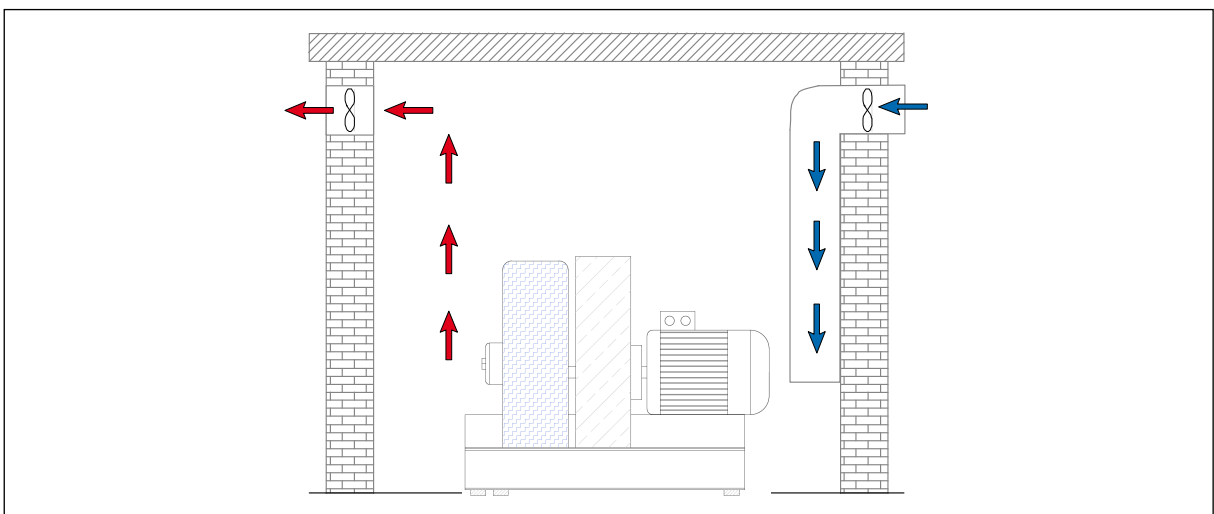

Fig. Ventilation via ventilation stack

INSTALLATION

Electrical Installation



Warning

Work on the electrical equipment on / with the machine / unit may only be carried out by qualified electricians.

For installation of electrical equipment, observe the following:

- If control devices are delivered by the factory, refer to the appropriate wiring diagram.
- Ensure correct installation of protective conductors.
- Check conformity of motor and control device tension and frequency with those of the electric network (see name plate on the compressor).
- The fusing should be done in accordance with the valid regulations of the responsible electricity supply company.
- When connecting the unit to the electrical supply, check the compressor direction of rotation (see chapter "Maintenance" -> Check turning direction).
- Fuse the motor correctly (see table; use slow-blow fuses).

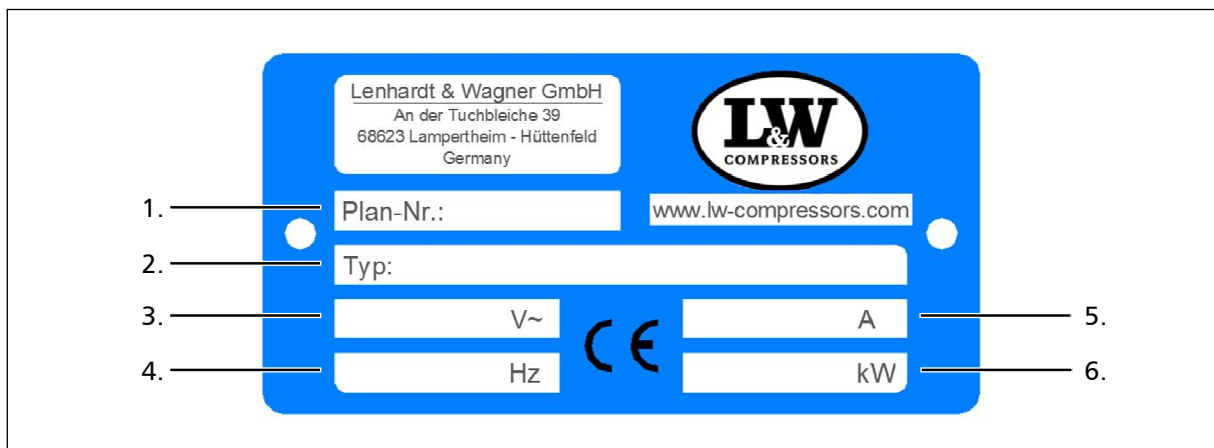

Fig. Compressor name plate

No.	Designation
1.	Circuit diagram number
2.	Compressor type
3.	Power supply
4.	Frequency
5.	Motor current consumption
6.	Nominal motor power

INSTALLATION

Electrical Installation

The standard compressor version is prepared for the connection to three phases (brown, black, grey), neutral conductor (blue) and protective earth conductor (green/yellow).

Fig. - Connection to the switch box

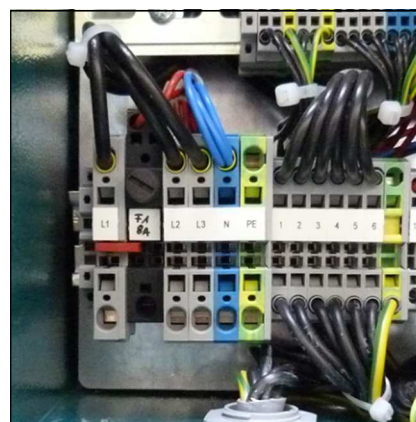

A

Recommended fuses for 360 - 500 V operating voltage

Nominal motor power		Fusing start A		Connection in mm ²	
[kw]	[A]	Direct	Star/Delta	Contactor supply	Motor S/D
18.5	36	-	50	6	4
22	41	-	50	10	4
30	55	-	63	10	6
37	68	100	80	16	6

Recommended fuses for 220 - 240 V operating voltage

Nominal motor power		Fusing start A		Connection in mm ²	
[kw]	[A]	Direct	Star/Delta	Contactor supply	Motor S/D
18.5	63	-	80	16	6
22	71	-	80	16	6
30	96	-	125	25	10
37	117	200	160	35	16



A

OPERATION



OPERATION

Important operation instructions



Note

Ensure that all persons handling the compressor are familiar with function and operation of the unit.



Wear hearing protection

When working on a running machine, always wear hearing protection.

A

FIRST COMMISSIONING

Prior to first commissioning, observe the following:

Necessary steps are described on the next page.

- Ensure that cooling air can flow freely.
- Check compressor oil level by the oil sight glass (see next page).
- Check all connections and retighten if necessary.
- Check if the filter cartridge is in place (see "Service and Maintenance").
- Check if all filling valves are closed. Open one filling valve and hold tight manually!

Start the compressor

1. Start the compressor by pushing the ON button.
2. Check turning direction - see the rotary direction arrow on the housing of the electric motor (see next pages). If the turning direction is wrong, immediately stop the compressor by pushing the OFF button and contact an authorised electrician.



Warning

Wrong impeller rotation direction!

Immediately after switching the compressor on, check the rotation direction. Depending on the place of installation, the phase sequence can influence the rotation direction.

3. Check oil pressure (if oil pressure gauge is installed).
4. Run the compressor for about 2 minutes.
5. Close the open filling valve carefully.
6. Run the compressor up to maximum pressure and check if the final pressure switch shuts off the compressor. If the final pressure switch does not shut off, switch off the compressor with the OFF button (see chapter "REMEDYING FAULTS").
7. Check the compressor unit for leaks (see "SERVICE AND MAINTENANCE")
8. Now check the condensate drain valves:
 - Fix the black condensate hoses
 - Drain test - press the test button
 - If correct, air escapes
9. Stop the compressor by pushing the OFF button.
10. Open all filling valves carefully to vent.

FIRST COMMISSIONING

Check oil level

**Warning**

Check oil level daily. Never start the compressor with a too low oil level. Risk of accidental loss, destruction or deterioration.

Check oil before each operation of the system!

The oil level should be between the middle and upper end of the oil sight glass. Never start the compressor with a too low oil level.

Refill new compressor oil at least when the oil level reached the middle of the indicated area.

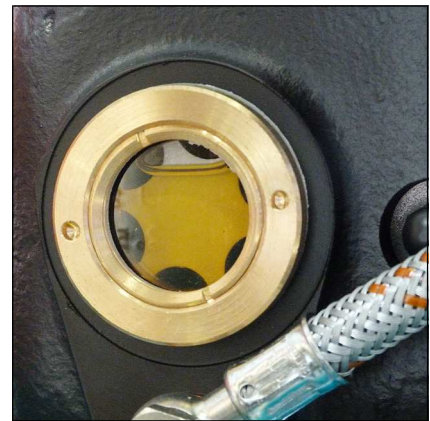

Oil sight glass

A

FIRST COMMISSIONING

Check turning direction



Warning

Wrong impeller rotation direction!

Immediately after switching the compressor on, check rotation direction. Depending on the place of installation, the phase sequence can influence the rotation direction.

Before starting the compressor for the first time, check rotation direction (see the rotary direction arrow on fan guard).

If the direction of rotation is wrong, the guide pistons can not be sufficiently lubricated, with the consequence that the pistons will be damaged. Furthermore, cooling air flow will not be sufficient.

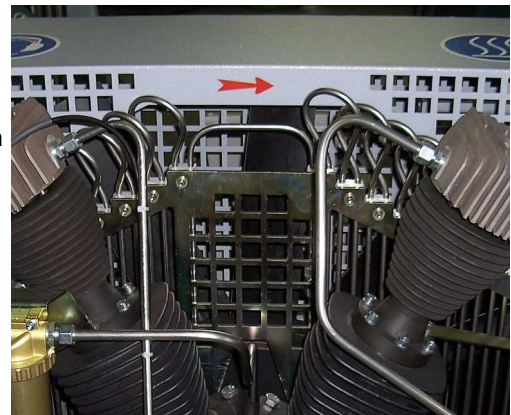

Rotation direction arrow

A



DAILY COMMISSIONING

Prior to daily operation observe the following:

- Ensure cooling air can flow freely.
- Check compressor oil level by the oil sight glass.
- Check if filter cartridge is in place / observe filter cartridge life!
- Ensure toxic-free, pure intake air.

A

OPERATION

Filling procedure



Caution! Fill only cylinders which:

- are marked with the test mark and the test stamp of the expert.
- have been hydrostatic tested (check last test date).
- are rated for the final pressure.
- are free from humidity.



Note

The unit shuts down when final pressure is reached. Thus, the unit always has to be restarted manually.

1. Close all filling valves.
2. Connect the closed compressed air cylinders.
3. Open cylinder valves.
4. Start compressor by pushing the ON button.
5. When the filling pressure gauge increases, open the filling valves slowly.
6. Fill compressed air cylinders to the desired pressure, subsequently close the filling valves slowly.
7. Close and vent all filling valves.
8. Disconnect all compressed air cylinders from filling valves.

A

OPERATION

Switch off the compressor

The compressor unit is equipped as standard with a pressure switch which automatically shuts down the system when the corresponding final pressure is reached.

During filling process, you can shut down the system at any time by pushing the red button (OFF) or the emergency stop (only in case of emergency!).



Note

After automatic or manual switching off, all pressure vessels and filter housings of the compressor will be automatically vented.

OPERATION

Interstage pressure gauges

Each of the 4 pressure stages is monitored by a single pressure gauge. This is serviceable for troubleshooting and allows detecting faults at an early stage.

Indicated interstage pressures depend on final pressure settings.

The pressure gauges should show the following values at a final pressure of 300 bar:

1st stage: approx. 2.8 bar (g)

2nd stage: approx. 17 bar (g)

3rd stage: approx. 70 bar (g)

4th stage: approx. end pressure

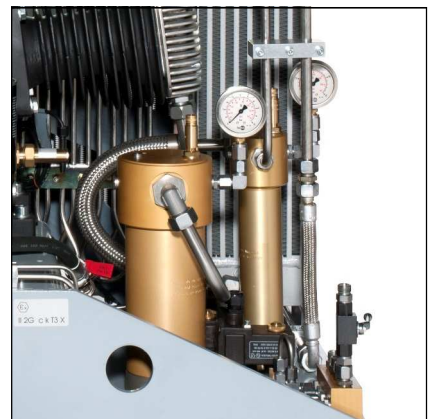

Fig. 1 - Interstage pressure gauge 1st and 2nd stage

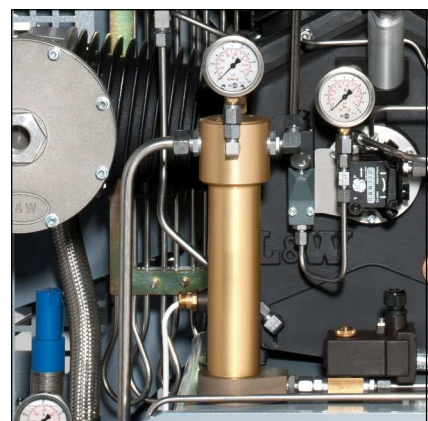

Fig. 2 - Interstage pressure gauge 3rd stage

A

OPERATION

Oil pressure gauge and oil distributor block gauge

The oil pressure gauge shows the compressor oil pressure during operation. Oil pressure values should remain between:

- min. + 0.5 bar
- max. + 4.0 bar

If oil pressure value stays below the minimum value:

- Wrong compressor rotation direction (see rotation direction arrow)
- Oil level too low, not enough oil in the compressor
- Oil pump sieve contaminated
- Oil intake hose damaged / defective
- Oil temperature below +5 °C - lubrication not possible
- Oil temperature higher than +120 °C - oil viscosity too low
- Oil pump defective



Oil pressure gauge and oil distributor block gauge

If oil pressure value stays above the maximum value:

- Low oil temperature, between +5 °C and +10 °C
- Should stay within the range of tolerance when operation temperature is reached..

Oil pressure control

If oil pressure remains outside the range of tolerance, it can be adjusted at the oil pump.

Increasing oil pressure

- Turn adjusting screw clockwise

Reduce oil pressure

- Turn adjusting screw anti-clockwise



Adjusting the oil pressure

OPERATION

Oil pressure monitoring

The oil pressure is maintained by a pressure switch during operation. The compressor automatically shuts off when oil pressure decreases below the minimum pressure of +0.5 bar. The red warning lamp "Oil Pressure Monitoring" lights up.

Possible causes of fault:

- Wrong compressor rotation direction
(see rotation direction arrow)
- Oil level too low, not enough oil in the compressor
- Oil pump sieve contaminated
- Oil intake hose damaged / defective
- Oil temperature below +5 °C - lubrication not possible
- Oil temperature higher than +120 °C - oil viscosity too low
- Oil pump defective



Oil Pressure Monitoring

A



A

REMEDYING FAULTS

REMEDYING FAULTS

A

Final pressure can not be reached

Cause of fault	Remedy
Connections leaky	Retighten or clean/replace if necessary
Final pressure safety valve leaky	Replace
Pipes / heat exchanger broken	Replace
Condensate drain valves leaky	Unscrew valves, check sealing surfaces, clean, replace if necessary
Final pressure switch stop unit	Verify settings, replace if necessary
Piston of pneumatic condensate valve sticks	Clean pneumatic condensate valve and restore function, check/replace o-rings, replace valve completely if necessary

Strong compressor vibration

Cause of fault	Remedy
Drive motor / Compressor unit loosely	Retighten mounting screws
Anti vibration mounts used up	Replace
Ground not levelled	Ensure a solid and level ground

Air supply too low

Cause of fault	Remedy
Inlet and outlet valves contaminated / defective	Clean, replace if necessary
Cylinder(s), piston(s) or piston ring(s) used up	Replace
See chapter "Final pressure can not be reached"	See chapter "Final pressure can not be reached"

REMEDYING FAULTS

Compressor overheated

Cause of fault	Remedy
Inlet filter cartridge contaminated	Replace
Ambient temperature too high	Improve room ventilation /
Cooling air inlet and outlet insufficient	Observe minimum distances (see Installation Instructions)
Air intake hose too long	Reduce length of the air intake hose
Air intake hose diameter too small	Use a larger diameter
Wrong compressor rotation direction	Ensure correct phase rotation,
Inlet and outlet valves contaminated / defective	Clean, replace if necessary

Safety valve leaks

Cause of fault	Remedy
Inlet and outlet valves of the following pressure stage defective	Clean, replace if necessary
Sinter filter of the following water separator blocked	Replace
Safety valve leaky	Replace

Oil taste in the air

Cause of fault	Remedy
Mole carbon filter cartridge saturated	Replace
Compressor oil unsuitable	Use prescribed oil quality
Filter cartridge unsuitable	Use prescribed filter type
Cylinder(s), piston(s) or piston ring(s) defective	Replace

REMEDYING FAULTS

Automatic condensate drain defective

Cause of fault	Remedy
Solenoid coils defective	Replace
Cable / supply cable defective	Repair, replace if necessary
Timer / relais defective	Replace
Sinter filter of pneumatic condensate valve blocked	Replace
Piston of pneumatic condensate valve sticks	Clean pneumatic condensate valve and restore function, check/replace o-rings, replace valve complete if necessary

Condensate drain starts before reaching final pressure

Cause of fault	Remedy
Pressure stages are not as prescribed, control pressure of pneumatic condensate valve too low	Check corresponding inlet and outlet valve, replace if necessary.
Piston sealing of pneumatic condensate valve contaminated / used up	Clean, replace if necessary
Timer / relais settings not correct	Adjust as prescribed
Timer / relais defective	Replace

Compressor stops before final pressure

Cause of fault	Remedy
Final pressure switch settings not correct	Correct settings
Opening pressure of the pressure maintaining valve too high	Correct settings
Fuse / circuit breaker has tripped Valid only for E models	Check fusing of the power supply / observe regulations
Emergency stop switch has tripped	Unlock emergency stop switch, close compressor housing door correctly

REMEDYING FAULTS

Filter life not sufficient

Cause of fault	Remedy
Pressure maintaining valve settings not correct	Adjust as prescribed
Filter cartridge unsuitable	Replace by a prescribed filter cartridge type
Filter cartridge too old	Observe expiration date
Filter cartridge packaging incorrect / damaged / already opened. Filter cartridge already partly saturated before change	Store filter cartridges properly, dispose defective cartridges
Operating temperature too high	Ensure sufficient ventilation
Cylinder(s), piston(s) or piston ring(s) defective	Replace

Oil consumption too high

Cause of fault	Remedy
Cylinder(s), piston(s) or piston ring(s) defective	Replace
Compressor oil unsuitable	Use prescribed oil quality
Operating temperature too high	Observe prescribed operating temperatures
Oil leak at the compressor block	Tighten corresponding mounting screws, if necessary replace corresponding paper sealing / o-ring / shaft seal



A

MAINTENANCE AND SERVICE

MAINTENANCE AND SERVICE

Service, Repair and Maintenance

Carry out service and maintenance work exclusively when the compressor is stopped and depressurised. The unit should be leak-checked regularly. Leaks can be preferably localised by using a leak detector spray (if necessary, brush pipes with soapy water).

We recommend that only authorised L&W service technicians carry out service work on the bearing of the compressor (crankshaft and connecting rods).

We urgently recommend that all maintenance, repair and installation work must only be carried out by trained personnel. This is necessary because all maintenance work can not be explained exactly and detailed in this manual.

Only use authentic spare parts for service work.



Danger

Components under pressure, such as hose ends, can quickly come loose when manipulated and can cause potentially fatal injuries due to the pressure surge. Any work on system parts may only be performed in a pressure-compensated state.



Warning

The use of accessories that have not been tested can lead to death or serious injury or damage to the unit. Only use authentic spare parts for service work.



Warning

Carry out maintenance or service work when the unit is switched off and protected against unexpected restart.



Warning

Risk of burns!

Carry out maintenance or service work when the unit has cooled down.



MAINTENANCE AND SERVICE

Daily before taking unit into operation

Maintenance work	Type	Quantity	Order No.
Check oil level	-	-	000001
Check condition of all filling hoses	-	-	-
Check filter cartridge lifetime	-	-	-
Operate unit to final pressure and check function of final pressure switch	-	-	-
Open manual drain valves of 2.3ltr filter housings	-	-	-

Every 3 months or as required

Maintenance work	Type	Quantity	Order No.
Check automatic condensate drain, open manual condensate taps	-	-	-
Check/Retorque all connections and bolts	-	-	-

Annually

Maintenance work	Type	Quantity	Order No.
Oil change, if less than 1000 operating hours	-	5.0	000001
Check opening pressure of final safety valve	-	-	-
Clean coolers	-	-	-
Clean all oil/water separators, if less than 500 operating hours	-	-	-
Service intake filter (depends on condition - if less than 500 operating hours)	-	-	-
Check all connections for leakage	-	-	-



MAINTENANCE AND SERVICE

Every 500 operating hours

Maintenance work	Type	Quantity	Order No.
Clean intake filter	-	1	002662
Check pressure maintaining/non-return valve	-	-	-

A



MAINTENANCE AND SERVICE

Every 1000 operating hours

Maintenance work	Type	Quantity	Order No.
Replace o-rings of intake filter housing	-	1	001316
Replace intake filter	-	1	002662
Replace sintered metal filter of oil/water separators	1st stage	1	002649
	2 / 3 stage	2	000173
	1 / 2 / 3 stage	3	002914
Replace o-rings of oil/water separators	1st stage	1	001306
	1st stage	2	001297
	2 / 3 stage	6	001272
Replace o-rings of oil/water separator	-	2	001294
Replace silencer	-	1	000178
Replace sintered metal filter of oil/water separators	-	2	000184
Replace sintered metal filter of pneumatic condensate valve	-	1	000188
Replace oil sieve and oil pump cover gasket	-	1	002569
Oil change	-	5.0	000001
Replace oil filter	-	1	003928
Replace o-rings of the final filter housing	-	6	001287
Replace back-up rings of the final filter housing	-	6	001285
Replace o-rings of filter housing (0.8 litre)	-	1	004221
Replace filter element of filter housing (0.8 litre)	-	1	003980
Replace back-up ring of the filter housing (0.8litre)	-	1	004222



MAINTENANCE AND SERVICE

Every 2000 operating hours

Maintenance work	Type	Quantity	Order No.
Replace all inlet and outlet valves incl. gaskets	1st stage	1	000936
	2nd stage	1	007827
	3rd stage	1	000551
	4th stage	1	000552
	Upper gasket 1st	1	002691
	Upper gasket 2nd	1	000257
	Lower gasket 1st	1	002690
	Lower gasket 2nd	1	005827

Every 4000 operating hours (Latest in 10 years)

Maintenance work	Type	Quantity	Order No.
Replace all o-rings and gaskets of 1st, 2nd, 3rd and 4th stage	gasket	4	002688
	o-ring	2	001296
Replace shaft seal	-	1	002714
Replace needle bearings for conrod 2nd, 3rd and 4th stage	-	6	006698

MAINTENANCE AND SERVICE

Service Kits

The service kits contain parts for maintenance according to the factory requirements.

The use of the service kits ensures that all required parts are ordered and replaced and gives assurance that all parts are included in the order. Depending on the model and interval, the service kits include parts such as O-Rings, Sinter Filter, Inlet Filter, V-Belts, Silencers, In-&Outlet Valve, Valve Seals and Compressor oil.



Service Kits

A

Service Kits LW 1300 E for 350 bar Versions since 06 / 2011

Compressor	Final Filter	Operating Hours	Order No.
LW 1300 E	0.8 l	1000 h	006819
LW 1300 E	0.8 l	2000 h	006820
LW 1300 E	0.8 l	4000 h	006821

Service Kits LW 1300 E for 350 bar Versions up to 05 / 2011

Compressor	Final Filter	Operating Hours	Order No.
LW 1300 E	1.7 l	1000 h	003876
LW 1300 E	1.7 l	2000 h	006818
LW 1300 E	1.7 l	4000 h	004271

Service Kits LW 1300 E for 420 bar Versions

Compressor	Final Filter	Operating Hours	Order No.
LW 1300 E	1.7 l	1000 h	008254
LW 1300 E	1.7 l	2000 h	008255
LW 1300 E	1.7 l	4000 h	008256

Compressor lubrication

Crankshaft bearings of the 1st and 2nd stage get lubrication by an oil slinger. In addition, 1st and 2nd stage are lubricated by spray oil. The 3rd and 4th stage are lubricated by a mechanical oil pump.

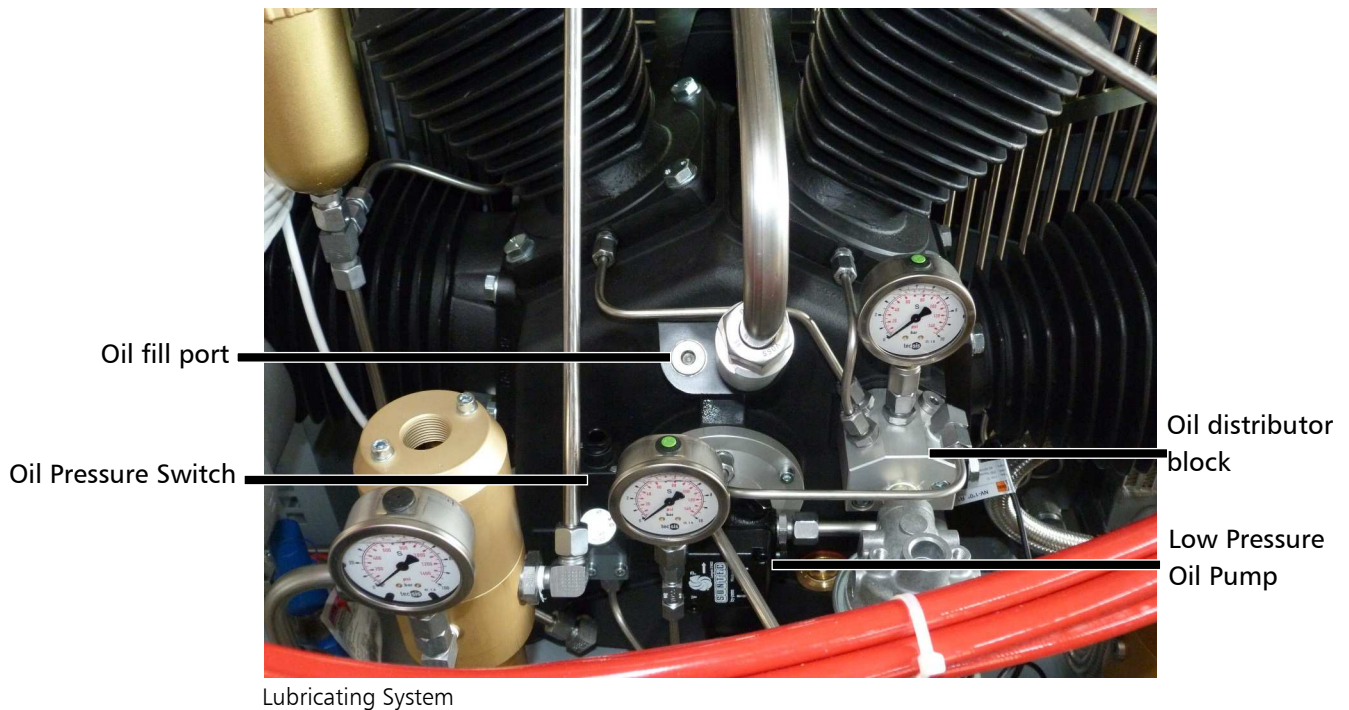

Check oil level



Warning

Check oil level daily. Never start the compressor with a too low oil level. Risk of accidental loss, destruction or deterioration.

Check oil before each operation of the system!

The oil level should be between the middle and upper end of the oil sight glass. Never start the compressor with a too low oil level.

Refill new compressor oil at least when the oil level reached the middle of the indicated area.

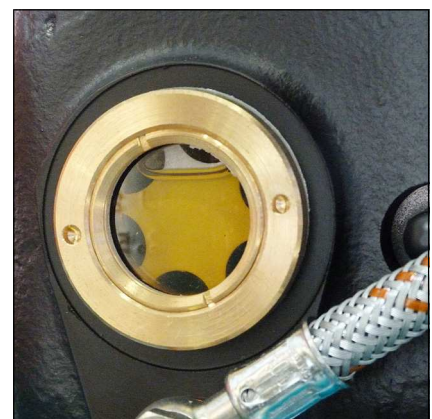

Oil sight glass

Oil change



Note

We recommend oil change at least once a year - depending on total operating hours.

A

Oil change as follows:

- Run compressor warm for approx. 2 min.
- Switch off and vent compressor.
- Place a suitable oil drain tray under the drain hose.
- Open carefully oil drain valve and drain oil completely.
- Close oil drain valve.
- Loosen oil fill port with an appropriate adjustable wrench (AF 0-40 mm) and unscrew manually.
- Fill oil by using a funnel.
- Check oil level. The oil level should be between the middle and upper end of the oil sight glass.
- Screw oil fill port manually in and tighten with the adjustable wrench.

The oil change is now completed.

Maintenance intervals

- First oil change after 25 operating hours (total hours).
- All further changes after each 1,000 operating hours.

Oil and oil capacity

Approx. 5,000 ml synthetic compressor oil is necessary for one oil change. Only use synthetic compressor oil which is recommended as suitable from L&W.

MAINTENANCE AND SERVICE

A

Oil sieve change

Oil sieve change as follows:

- Loosen cover screws (4 pcs).
- Remove the cover, the cover gasket and the oil sieve.
- Clean the oil sieve with petroleum-ether or replace the defective oil sieve.
- Replace the gaskets.
- Soak the gaskets with oil before placing (respect mounting direction).
- Be sure to position the arrow (see Fig., Pos. 1) from the new oil sieve opposite to inlet and return ports of the pump (see Fig., Pos. 2).
- Remount the cover with the 4 cover screws. Tightening torque: 4.5 - 8 N.

The oil sieve change is now completed.

Maintenance intervals

- We recommend cleaning or replacing the oil sieve every 1,000 working hours.
- Service Kit oil pump (002569). Consists of: 000798—Oil sieve + 000672—oil pump cover gasket

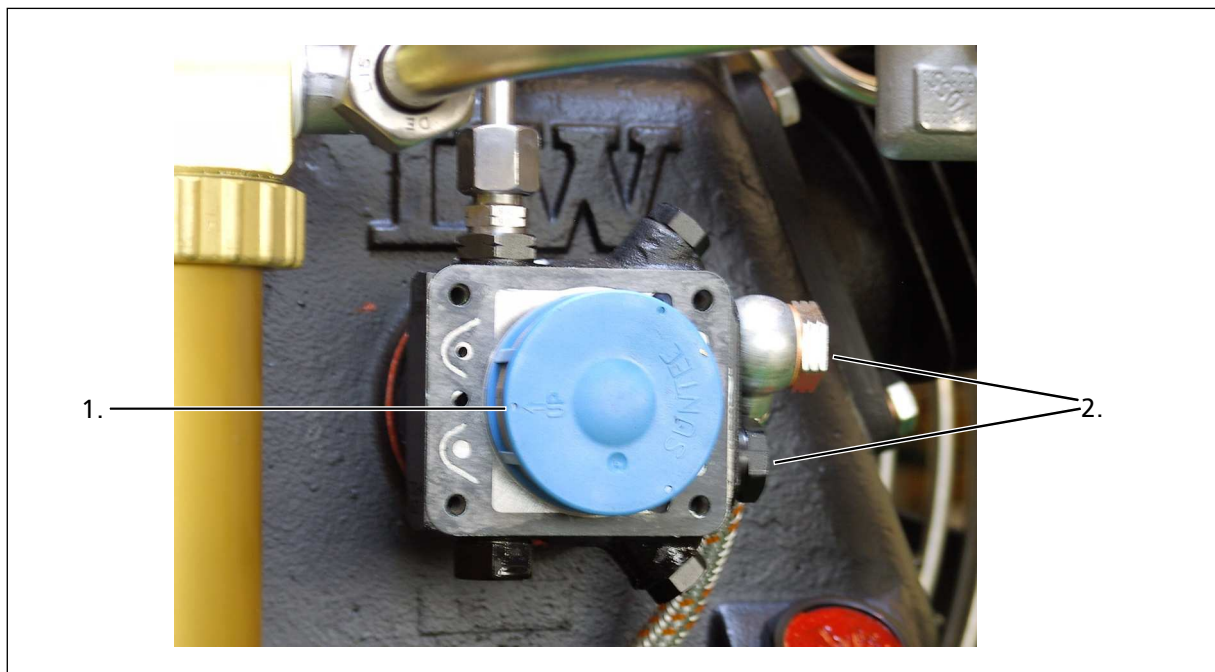

Correct oil sieve mounting direction

Final pressure switch



Note

Do not adjust the final pressure switch to the safety valve pressure. The final pressure switch has to be adjusted to min. 10 bar below the safety valve pressure. Otherwise, the safety valve can open during operation. This considerably reduces the life of the safety valve.

The pressure switch shuts off the compressor automatically when the selected final pressure is reached. The final pressure switch is already adjusted to the corresponding cut-out pressure.

The pressure can be adjusted with the upper adjusting screw as follows:

Increasing cut-out pressure:

Turn the adjusting screw clockwise

Reducing cut-out pressure:

Turn the adjusting screw anti-clockwise

Adjust the pressure switch in steps of a quarter turn. Restart the compressor after every adjustment step to verify the actual cut-out pressure.

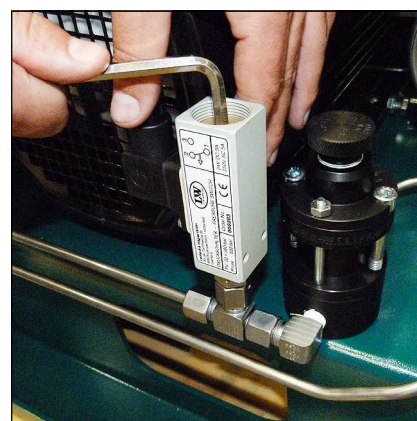

Final pressure switch

Example settings:

Safety valve	Max. Operating Pressure
225 bar	215 bar
250 bar	240 bar
330 bar	320 bar
330 bar	320 bar
365 bar	350 bar
420 bar	400 bar
450 bar	420 bar

Automatic condensation dump system



Note

The collected condensate can contain oil and has to be disposed according to regulations.

The LW 1300 E comes as standard with an automatic condensation dump system. Solenoids drain all condensate separators every 15 minutes.

To test the system, press the blue condensate test drain button on the operating panel.

Oil / water separators

Condensate is separated after every stage of compression. All four oil / water separators are equipped with electronic timer controlled solenoids. The timer is located in the switch box and activates the dump valves about every 15 minutes.

To release the complete condensate through the black plastic hoses, we recommend using an 60 l container at least.

The drain noise can be kept to a minimum by using a silencer.

Maintenance intervals

We recommend to clean oil and water separators every 500 operating hours or at least once a year, to check for corrosion damage and to replace o-rings if necessary.

All oil / water separators have an integrated sinter filter which has to be replaced every 1,000 operating hours.

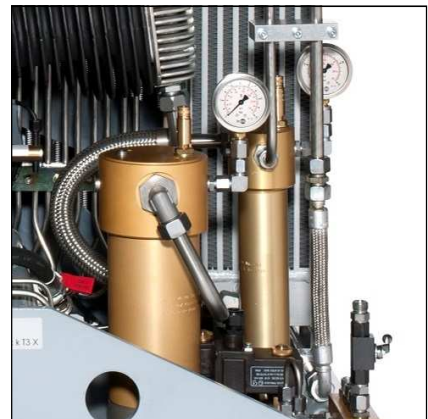

Oil / water separators 1st, and 2nd stage

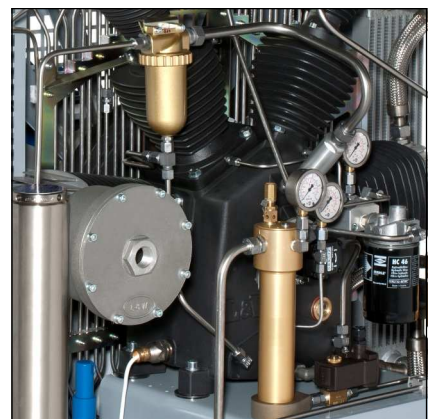

Oil / water separators 3rd and final stage

Oil / water separators 1st, 2nd and 3rd stage - maintenance



Note

Clean all parts thoroughly before assembly. The figures of the parts can differ due to the different stages.

Maintenance / cleaning of oil / water separators as follows:

- Loosen pipe connections and mounting screws.
- Remove oil / water separators.
- Unscrew and remove filter top.
- Open nut and remove separator top (Fig. 1).
- Change sinter filter (Fig. 2).
- Reassemble all parts and tighten nut.
- Change o-ring, previously grease new o-ring (Fig. 3).
- Place separator top and tighten manually.
- Remove bottom part (Fig. 4)
- Change o-ring, previously grease new o-ring
- Press in bottom part
- Mount oil / water separators.
- Change sinter filter which is sitting between oil/water separator housing and condensate drain outlet connection. (Fig. 5)
- Tighten pipe connections and mounting screws.

The oil / water separator maintenance is now completed.



Fig. 1 - Loosen nut at the separator top



Fig. 2 - Change sinter filter



Fig. 3 - Change o-ring



Fig. 4 - Bottom part

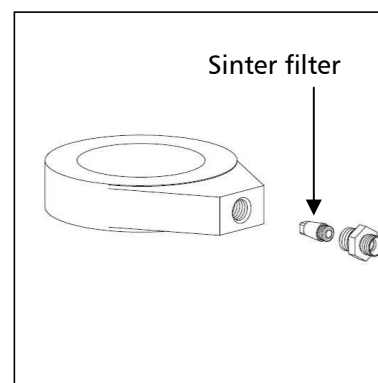

Fig. 5 - Sinter filter

MAINTENANCE AND SERVICE

Oil / water separators final stage - maintenance



Note

Clean all parts thoroughly before assembly.

Change/clean oil / water separators final stage as follows:

- Loosen pipe connections and mounting screws.
- Remove oil / water separators.
- Open ring nut and remove separator top (Fig. 1).
- Loosen nut at the separator top.
- Change sinter filter (Fig. 2).
- Reassemble all parts and tighten nut.
- Change o-ring, previously grease new o-ring (Fig. 3).
- Place separator top and tighten ring nut manually.
- Replace silencer.
- Mount oil / water separators.
- Tighten pipe connections and mounting screws.

The oil / water separator maintenance is now completed.



Oil / water separators final stage



Fig. 1 - Loosen ring nut

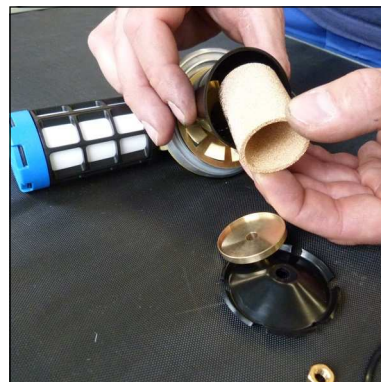

Fig. 2 - Change sinter filter

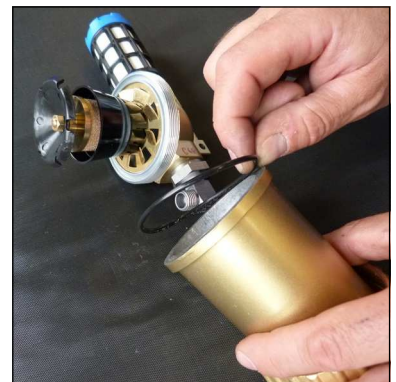

Fig. 3 - Change o-ring

MAINTENANCE AND SERVICE

Filter element change 0.8ltr filter housing

Filter element change as follows:

- Start the compressor and run up to a pressure of 100 bar.
- Stop the compressor.
- Open the filling valve.
- Loosen pipe connections and mounting screws (Fig. 1 a. 2)
- Remove complete filter housing.
- Open filter cover (Fig. 3).
- Change the filter element (stuck in filter cover) (Fig. 4).
- Change o-ring, previously grease new o-ring .
- Grease thread of filter cover, o-ring and back-up ring.
- Reassemble filter cover and filter housing. Note the correct position of th filter back-up!
- After you have screwed it completely, loosen the filter cover about 90 °. This avoids a terminals of the filter cover due to a hard shaking while operation.

The filter cartridge change is now completed.



Note

Ensure that the old filter element is disposed correctly at an approved waste point.



Fig. 1 - Loosen pipe connections and mounting screws



Fig. 2 - Loosen pipe connections and mounting screws

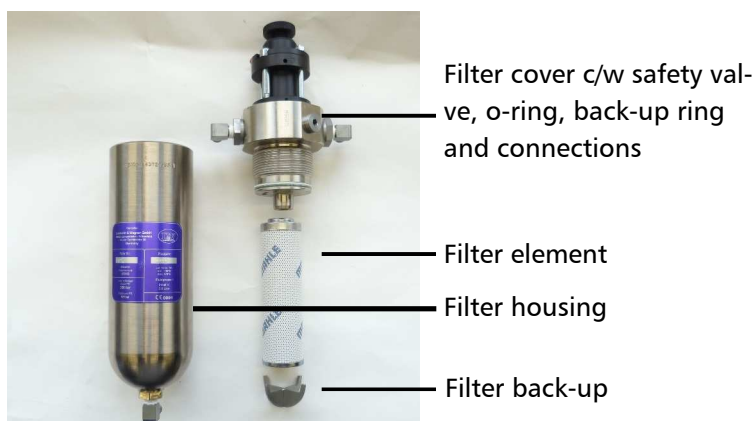

Fig. 4 - 0.8ltr Filter housing parts



Fig. 3 - Open filter cover

Pneumatic condensate valve - maintenance



Note

Clean all parts thoroughly before assembly.

Pneumatic condensate valve change as follows:

- Loosen pipe connections and mounting screws.
- Remove pneumatic condensate valve.
- Loosen connection (Fig. 2).
- Change sinter filter (Fig. 3).
- Tighten horizontal screw.
- Mount pneumatic condensate valve.
- Tighten pipe connections and mounting screws.

Pneumatic condensate valve maintenance is now completed.



Pneumatic Condensate Valve



Fig. 2 - Loosen connection

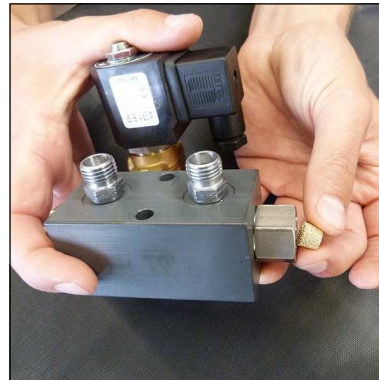

Fig. 3 - Change sinter filter

MAINTENANCE AND SERVICE

Filter panel

The mole carbon filter panel is delivered together with the compressor. Inside the filter housing a jet blows air on to the housing wall. Condensation water and oil are led by centrifugal force to the bottom of the housing. Air flows through the mole carbon filter cartridge, which purifies the air from residual moisture and odours. The black condensate drain valves needs to be opened dailey to drain the water.



Warning

Open valve spindle max. 1.5 turns.

The pressure in the housing can shoot out the valve spindles at high speed.



Filter panel

A

Filter cartridge

The high-pressure compressor is equipped with an integrated breathing air purification system. Air is compressed up to 330 bar, dried and odour- and tasteless purified. Oil residues are bounded. The breathing air filter cartridge consists of a molecular sieve and activated-carbon filter.

Cartridge capacity: approx. 2.3 l

All breathing air filter cartridges are factory vacuum sealed.

We recommend unpacking the filter cartridges just before installation. Filter cartridges which are exposed too long could be saturated with moisture and become unusable.

P/N	Filtering	Models
000003	DIN EN 12021 (Breathing Air)	For models with 2.3 ltr Filter housings
001461	DIN EN 12021 (Breathing Air) incl. CO/CO2	For models with 2.3 ltr Filter housings
001467	Only oil / odour removal (<0,1mg/m ³)	For models with 2.3 ltr Filter housings
001462	Only drying (<15mg/m ³)	For models with 2.3 ltr Filter housings
001468	CNG filter (drying and oil removal)	For models with 2.3 ltr Filter housings

Maintenance intervals

Filter cartridges should be changed at the following intervals, at +20°C or more often, depending on humidity and ambient temperature:

- 46 hours

MAINTENANCE AND SERVICE

Filter cartridge change

Filter cartridge change as follows:

- Run the compressor up to a pressure of 100 bar.
- Stop compressor.
- Open filling valve.
- Unscrew filter housing cover by using the special filter tool (Fig. 1).
- Place the T-piece end of the filter tool in the recess of the filter cartridge (Fig. 2).
- Unscrew the filter cartridge anti-clockwise and pull the cartridge out of the housing (Fig. 3).
- Open the packing of the new filter cartridge and place it with the filter tool in the filter housing.
- Screw the new filter cartridge hand tight in by using the filter tool.
- Screw the cover of the filter housing first manually in.
- After it has been completely screwed in, turn cover anticlockwise for 90°. This avoids tightening of the cover due to vibration..

The filter cartridge change is now completed.



Note

Ensure that the old filter cartridge is disposed correctly at an approved waste point.



Fig. 1 - Unscrew the filter housing cover.



Fig. 2 - Place the T-piece end of the filter key in the top of the filter cartridge.



Fig. 3 - Pull the cartridge out of the housing.

A

MAINTENANCE AND SERVICE

Filter housing - maintenance



Note

Clean all parts thoroughly before assembly.

Filter housing maintenance as follows:

- Open Filter Cover (Fig. 1).
- Change o-ring and back-up ring, previously grease both (Fig. 2).
- Grease filter cover thread and close.

Dismount filter housing

- Loosen u-clamps and pipe connections and nuts (Fig. 3).
- Remove filter housing.
- Dismount filter housing base.
- Change o-ring and back-up ring, previously grease both (Fig. 4).
- Screw filter base tight in.

Mount filter housing

- Connect pipe connections and tighten.
- Adjust u-clamps and tighten nuts.

The filter housing maintenance is now completed.

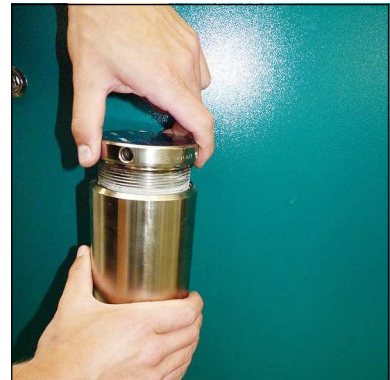

Fig. 1 - Open Filter cover

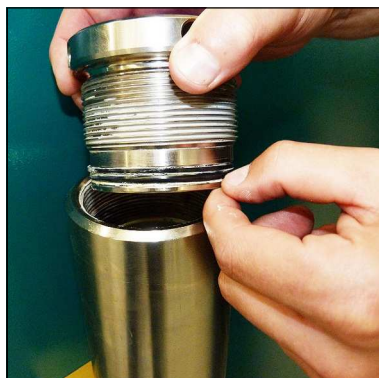

Fig. 2 - Change o-ring and back-up rings



Fig. 3 - Loosen u-clamps and pipe connections



Fig. 4 - Change o-ring and back-up rings

MAINTENANCE AND SERVICE

Inlet filters



Note

Dirty filters make intaking air difficult and reduce delivery capacity. Risk of compressor overheating.

A micro filter cartridge is used as an air inlet filter. Check air inlet filter regularly or replace it. Defective air inlet filters should be immediately replaced with a corresponding filter.

Maintenance intervals

We recommend that the filter cartridge should be replaced every 1,000 working hours (depending on pollution grade).

Inlet filter cartridge change

Inlet filter cartridge change as follows:

- Loosen cover by removing the bolts.
- Change inlet filter cartridge and o-ring.
- Refit cover and tighten the bolts.

The inlet filter cartridge change is now completed.

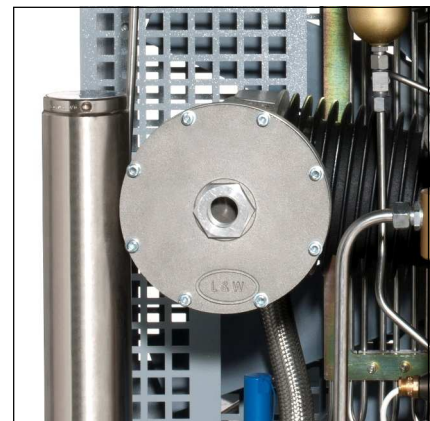

Air inlet filter housing

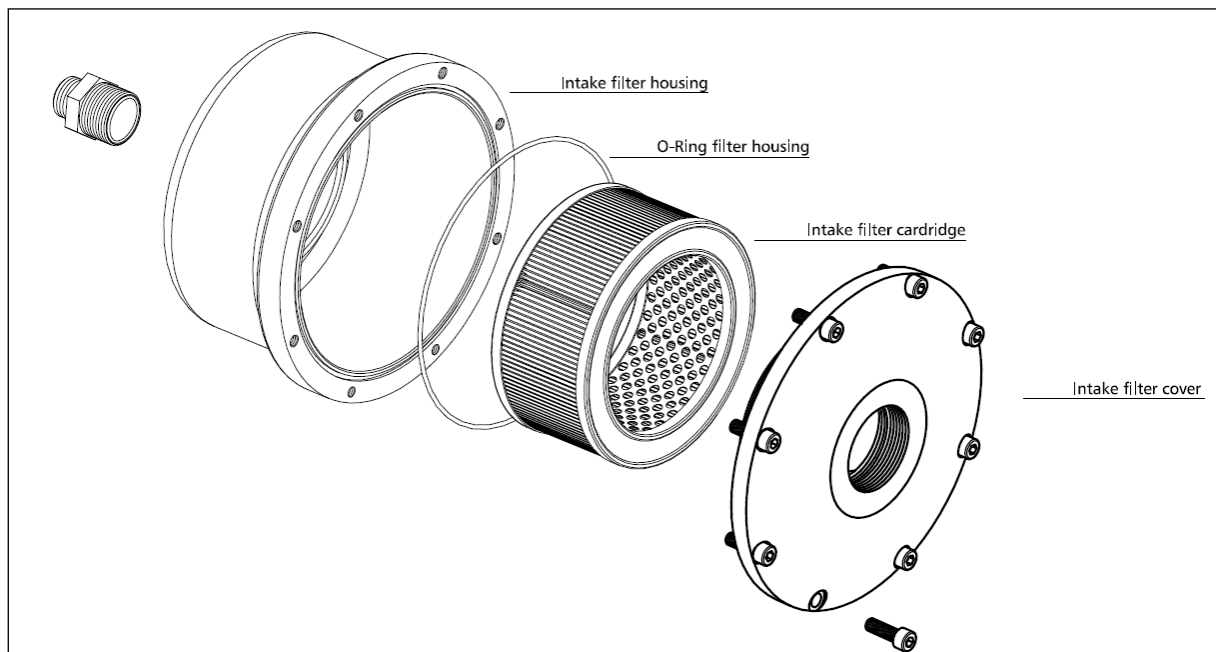

Filter cartridge inlet filter

MAINTENANCE AND SERVICE

Cylinder heads and valves

Inlet and outlet valves of the specific compressor stages are located between valve head and cylinder. Outlet valves open while piston downstroke, inlet valves open while upstroke or compression stroke.

Valves are subject to normal wear and tear and have to be replaced at certain intervals (depending on specific operating conditions). Dismount valve heads to change valves. All valves are combined inlet and outlet valves. The first and second stage valves are plate valves. The third and fourth stage contains a spring operated piston which acts inside a bronze cylinder.

Maintenance intervals

All valves should be replaced after 2,000 working hours due to normal wear and tear. To replace valves the cylinder heads have to be removed. There are no special tools required to replace these valves.

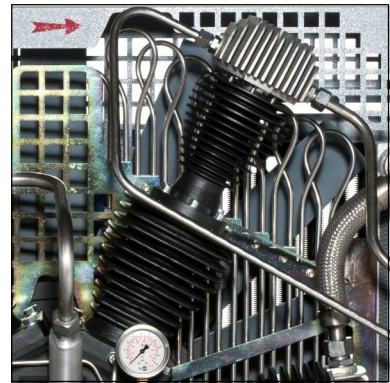

Fig. 1 - 3rd stage

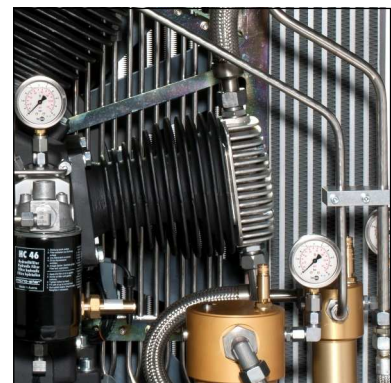

Fig. 2 - 2nd stage



MAINTENANCE AND SERVICE

Important torque rates for bolts

Cylinder heads

Stage	Tightening torque	Thread
1st Stage	85 Nm	M12
2nd Stage	55 Nm	M10
3rd Stage	30 Nm	M8
4th Stage	30 Nm	M8

Adapterplate for flywheel

Thread	Tightening torque	Grade
M12	140 Nm	12.9
M14	220 Nm	10.9

More standard torque for bolts

Description	Tightening torque	Thread	Grade
Flywheel	132 Nm	M14	8.8
Crankshaft counterweight	185 Nm	M14	10.9
Rubber coupling	350 Nm	-	-
Tension bolt connecting rod	25 Nm	M8	8.8

MAINTENANCE AND SERVICE

Safety valves

Every pressure stage is equipped with a separate over pressure safety valve. Safety Valves avoid a non permissible high pressure at the specific pressure stages and limit maximum operation pressure of the compressor.

Safety valves are adjusted to:

- 1st Stage: 8 bar
- 2nd Stage: 22 bar
- 3rd Stage: 90 bar
- 4th Stage: max. final pressure

The adjusted blow-off pressure [bar] of the safety valves is indicated on their housings.

All safety valves are factory sealed with special L&W safety seals to avoid manipulation of the limit value settings.

Safety valves with removed seals have to be immediately checked for the prescribed settings and replaced if necessary.

The safety valve of the final stage is furthermore equipped with a knurled screw to be activated once.

Turning the knurled screw clockwise could vent the valve completely and therefore the final filter housing.

During normal operation conditions, the knurled screw has to be turned anti-clockwise up to the upper stop. An integrated circlip avoids complete unscrewing.

If a safety valve blows off, it indicates problems with either inlet or outlet valve of the following stage.



Note

Replace defective safety valves immediately!

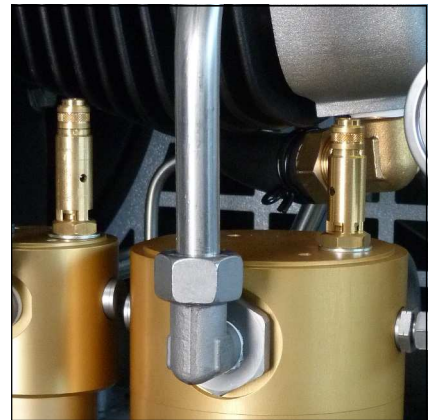

Safety valve 1st and 2nd stage



Safety valve 3rd stage



Safety valve 4th stage

A

Pressure maintaining / non return valve



Note

If the adjusted opening pressure of the pressure maintaining valve is higher than the final pressure of the compressor, the final pressure safety valve blows off before pressure maintaining valve opens (final pressure = 0 bar). When valve settings are not clear (e.g. after disassembly / repair), start the adjustment with a low basic setting (turn adjusting screw approx. 3 times in).

A pressure maintaining / non return valve is installed after the mole carbon filter housing. It maintains a pressure of at least 150 bar inside the filter housing - this optimises filter efficiency.

Pressure maintaining valve

The pressure maintaining valve drains a large part of the water content of the compressed air mechanically by ensuring the minimum outlet pressure. This guarantees optimal drying and purification of the breathing air.

After starting the compressor, the pressure inside the final filter housing constantly increases. The pressure maintaining valve prevents the compressed air from blowing off (final pressure gauge = 0 bar).

When the adjusted opening pressure is reached (150 and 180 bar), the purified compressed air flows via pressure maintaining and non return valve to the filling valve.

The value of the opening pressure of the pressure maintaining valve can be read at the final pressure gauge. When opening pressure is reached, the pressure gauge value increases within a few seconds.



Pressure maintaining/non-return valve

MAINTENANCE AND SERVICE

Safety valve test



Note

Do not fill any tank during test phase!

Safety valve test as follows:

- Disconnect compressor from the electrical power supply and protect against unexpected restart.
- Remove the cover of the switch box.
- Switch on the "Test Safety Valve" switch (pressure switch will be deactivated!).
- Mount the cover of the switch box.
- Connect the compressor to the electrical power supply.
- Close filling valves.
- Start the compressor.
- Watch the final pressure gauge. The safety valve should open when reaching working pressure of the compressor. If not, switch off the unit and take out of service until the safety valve has been replaced.
- Switch off the compressor.
- Disconnect the compressor from the electrical power supply and protect against unexpected restart.
- Remove the cover of the switch box.
- Switch off the "Test Safety Valve" switch (pressure switch will be activated!).
- Mount the cover of the switch box.
- Connect the compressor to the electrical power supply.

The safety valve test is now completed.

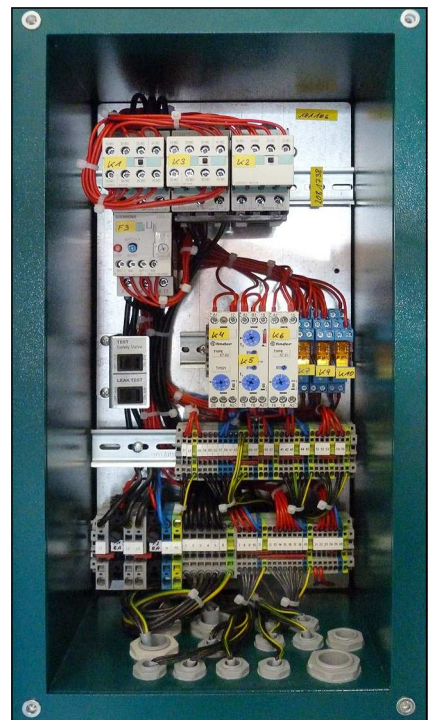

Switch box

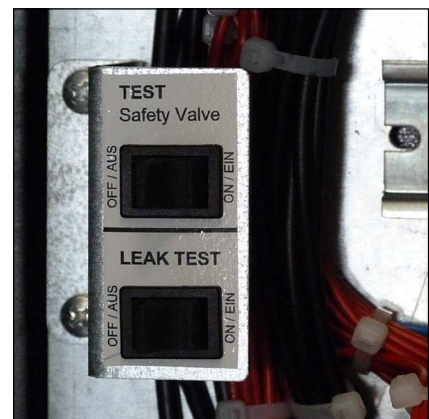

Safety valve test switch (up)

MAINTENANCE AND SERVICE

Leak test



Note

Do not fill any tank during test phase!

Leak test as follows:

- Disconnect the compressor from the electrical power supply and protect against unexpected restart.
- Remove the cover of the switch box.
- Switch on the leak test switch (solenoid valves will be deactivated!).
- Mount the cover of the switch box.
- Connect the compressor to the electrical power supply.
- Close filling valves.
- Start the compressor.
- Switch off the compressor at a pressure of approx. 150 bar.
- Verify the compressor for release noises. (A slight hiss of the air inlet filter nozzle can be ignored). If release noises occur, localise blow off position(s).
- Switch off the compressor.
- Disconnect the compressor from the electrical power supply and protect against unexpected restart.
- Remove the cover of the switch box.
- Switch off the leak test switch (solenoids will be activated!).
- Mount the cover of the switch box.
- Connect the compressor to the electrical power supply.

The leak test is now completed.

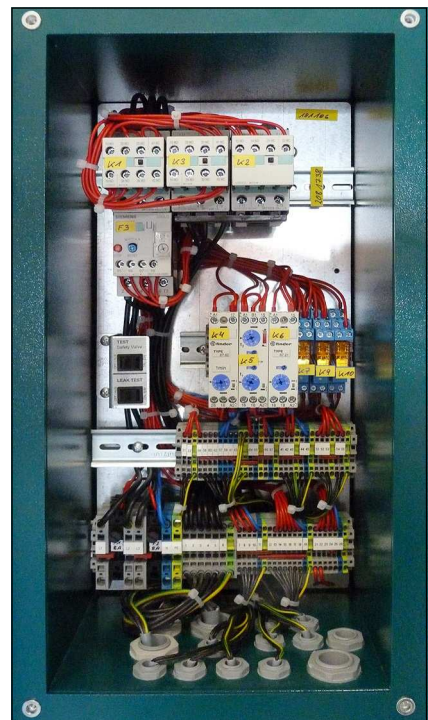

Switch box



Leak test switch (lower)

MAINTENANCE AND SERVICE

Test of pressure equipment

According to the Pressure Equipment Directive (PED 97/23/EC) and TÜV Darmstadt (German supervising authorities). State: 10th of December, 2005

Subject: pressure equipment with a product permissible operating pressure [bar] x content volume [litres] from 200 up to 1000.

Example: Filter housing 1.7 l

Maximum operating pressure: 350 bar

Content volume: 1.7 litres

$350 \text{ bar} \times 1.7 \text{ litres} = 595$

595 is smaller than 1000 -> result: Test is applicable!!

Example: Filter housing 2.3 l

Maximum operating pressure: 350 bar

Content volume: 2.3 litres

$350 \text{ bar} \times 2.3 \text{ litres} = 805$

805 is smaller than 1000 -> result: Test is applicable!!

Pressure equipment from 200 up to 1000 have to be tested as follows:

1. Examination after 5 years by a qualified person or authorized organisations.

Visual inspection, inside and outside.

2. Examination after 10 years by a qualified person or authorized organisations.

Visual inspection, inside and outside.

In addition, a water pressure test is carried out at 1.5 times of the permissible vessel operating pressure.



A

MAINTENANCE RECORDS



MAINTENANCE RECORDS

Introduction form for the Operator

A

No.	Surname, Name	Date	Place	Signature	Instructor

By adding themselves to this list, the person that signs it confirms having been given a yearly introduction/instruction about the function and operation of the compressor unit. Furthermore, they have be informed about the relevant safety rules and regualtions (TRG, DGRL, BetrSichV, GSG, GSGV).



MAINTENANCE RECORDS

Top up oil, oil change

Date	Operating hours	Oil quantity [l]	Name

A



MAINTENANCE RECORDS

Cartridge change

Date	Operating hours	Difference	Name

A



MAINTENANCE RECORDS

Maintenance work

Description	Date, signature

A



MAINTENANCE RECORDS

Replaced Parts

Designation	Part number	Date, signature

A



A

STORAGE

STORAGE

Conservation / storage of the compressor

If the compressor unit is not to be used for an extended period of time, we recommend to carry out the following work before storage time:

- Run the compressor at 200 bar filling pressure for approximately ten minutes (control the flow with the filling valve to maintain constant pressure).
- Replace compressor oil, open filling valve(s) and run compressor for a few minutes.
- Stop compressor and open drain valves (depending on the compressor type, this may happens automatically). Remove top cap of final filter housing: clean throat, grease o-ring. and throat with a food grade grease or silicone grease. Close filter housing.
- Remove intake filter cartridge and undo intake pipes on all valve heads.
- Start compressor unit. Spray a few drops of compressor oil into intake connectors.
- Stop compressor unit and insert intake filter cartridge. Bring intake pipes back in position and fix connections and nuts. Close filling- and drain valves.
- Store the compressor in a cool dry place free from dust and contamination. A dust cover is recommended as long as condensation can be avoided.
- If compressor unit should be stored for a period of more than one year, an oil change is strongly recommended before it's been re-used.
- Fuel driven units only: fill up fuel tank to top level to avoid corrosion.

De-conservation, commissioning

After the compressor has been stored, the following steps are to be taken:

- If compressor hasn't been used for longer than 12 months, we strongly recommend an oil change before any use.
- Replace intake filter cartridge and check oil level.
- Clean compressor unit, check for foreign objects. Check condition and tension of V-belts, replace if necessary. Check condition of filling hoses, replace if necessary.
- Secure hoses against whipping and open filling valves and run compressor for approximately 10 minutes.
- Check condition of final filter cartridge, replace if necessary.
- Close filling valves and run compressor up to final pressure.
- Check safety valve relief pressure of final stage and/or pressure switch setting.
- Check all connections and pipe work for leaks.

Once all above steps are completed, compressor unit is now ready for use.

STORAGE

Transportation instructions

- Parts which need to be dismantled for transport purposes must be carefully replaced and secured before taking into operation.
- The transport may only be carried out by trained personnel.
- For transportation, only use lifting devices and equipment with sufficient lifting power.
- Do not stand or work under suspended loads.
- Also separate from minor relocation machinery / system of any external energy supply. Before recommissioning, reconnect the machine to the mains according to regulations.
- When recommissioning, proceed according to the operating instructions..

Disposal

The product must be disposed in accordance with national waste disposal regulations and by an appropriate waste disposal company.

Electric and electronic components

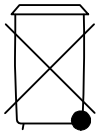

EU-wide regulations for the disposal of electric and electronic appliances which have been defined in the EU Directive 2002/96/EC and in national laws are effective from August 2005 and apply to this device.

Common household appliances can be disposed by using special collecting and recycling facilities. However, as this device has not been registered for household usage, it must not be disposed of through these means.

The device can be returned to L&W. Please do not hesitate to contact us if you have any further questions on this issue.

Operating Instructions

ECC - Electronic compressor control





TABLE OF CONTENTS

General Information

General Information	3
Description of Warning Symbols	3

Description

Specifications / Options	4
Switchboard	5

Operation and Function

Main Menu	6
Selection Menu (M100)	7
Display Menu (M200)	8
Inter-Stage Pressure Display.....	8
Display II (M270)	9
Settings Menu (M300).....	10
Set Stop Pressure - automatic mode (M320).....	11
Set Restart Pressure - automatic mode (M330).....	11
Set Stop Pressure - semi-automatic mode (M340)	11
Test Menu (M400)	12
Test Solenoids (M420)	12
Test safety valve (M430)	13
Test stop without venting (M440)	13
Statistics Menu (M500).....	14
Maintenance Menu (M600)	15
Confirm Maintenance (M680).....	16
Operation Mode (M700).....	17
Language Menu (M750)	17
Adjusting Display Backlight.....	18
Software Update	18
Spare part lists.....	19
Manufacturer in terms of 97/23/EC.....	20

B



GENERAL INFORMATION

General Information

We strongly recommend reading this manual thoroughly prior to operation and follow all the safety precautions precisely. Damage resulting from any deviation from these instructions is excluded from warranty and liability for this product. Carry out other commissioning steps only if you have fully understood the following contents.

Before commissioning and using the unit, carry out all the essential preliminary work and measures concerning legal regulations and safety. These are described on the following pages of this operation manual.

B

Description of marks and warning signs

The following warning signs are used in this document to identify the corresponding warning notes which require particular attention by the user. The warning signs are defined as follows:



Caution

Indicates an imminently hazardous situation which, if not avoided, could result in serious injury, physical injury or death.



Warning

Indicates a potentially hazardous situation which, if not avoided, could result in physical injury or damage to the product or environment.



Note

Indicates additional information on how to use the unit.



DESCRIPTION

Specifications and Options

All L&W compressors can be optionally equipped with the all-electrical computer supported control system "ECC". It is easy to operate and allows multiple and individual settings.

Specifications

- LCD-Display with key pad
- Automatic & semi-automatic operation mode
- Automatic dump system
- Integrated counter for operation hours
- Integrated counter for load cycles
- Maintenance intervals automatically displayed
- Required service part numbers automatically displayed
- Fully adjustable pressure ranges for start and stop
- Warning messages ("Housing Open" / "Emergency Switch")
- Check of end-pressure safety valve possible
- Auto switch-off when system is not running
- Extendable by additional modules (e.g. external filling panel)
- Easy to operate menu
- Door position switch (housing open message)
- Load-free or depressurised start cycles

Options

- Oil pressure control
- Oil temperature control
- Cylinder head temperature control
- Inter stage pressure monitoring
- PIN controlled access
- Master / slave option (if more than one ECC equipped compressors are combined)

DESCRIPTION

Switchboard



No.	Description
1	LCD Display
2	Key Pad
3	LED Display (Compressor OFF)
4	LED Display (Power)
5	LED Display (Compressor ON)



OPERATION AND FUNCTION

Main Menu

Immediately after the compressor has been connected to power, the ECC-display shows the following Main Menu::

Charging	0 min
Total	0,0 h
Start : 1	Stop : 0
Help: *	OFF
Final Press	0 bar

Present filling time in minutes

Total operation hours

Key 1 to start compressor / Key 0 to stop compressor

* Key leads to submenus Current operation state = Off

Present filling pressure

B

The following keys can now be used:

Key	Function / Description
1	Start - Starts the compressor
0	Stop - Stops the compressor
*	Leads to the submenus

After typing the * key the following Selection Menu appears.



OPERATION AND FUNCTION

Selection Menu (M100)

After typing the * key in the Main Menu the following Selection Menu appears.

Selection:		
2	Display	Key 2 leads to submenu "Display"
3	Settings	Key 3 leads to submenu "Settings"
4	Test	Key 4 leads to submenu "Test"
5	Statistics	Key 5 leads to submenu "Statistics"
6	Maintenance	Key 6 leads to submenu "Maintenance"
7	Operation Mode	Key 7 leads to submenu "Operation mode"
(M100)	Return : #	Key # leads back to "Main Menu"

B

(M100) tells that you are currently on menu page 100.



Note

At any time, the unit can be started with key 1 or shut down with key 0.
Caution: Risk of accident during maintenance work!

OPERATION AND FUNCTION

Display Menu (M200)

Pushing key 2 in the Selection Menu leads to Submenu "Display".

Display I:	
2	Press. Stage 1
3	Press. Stage 2
4	Press. Stage 3
5	Cyl. Head Temp.
6	Oil Temp.
7	Display II
(M200)	Return : #

Key 2 shows current pressure of the 1st stage*

Key 3 shows current pressure of the 2nd stage

Key 4 shows current pressure of the 3rd stage

Key 5 shows temperature of the final stage cylinder head

Key 6 shows the oil temperature

Key 7 shows Display II

Key # leads back to "Main Menu"

(M200) tells that you are currently on menu page 200.

By pushing key 2 (inter-stage pressure 1) the following Display appears.

Inter-Stage Pressure Display

Pushing key 2 in the Display Menu leads to the Inter-Stage Pressure 1 Display Menu.

Charging	0 min
Total	0,0 h
Start: 1	Stop: 0
Help:*	OFF
Press.	0 bar
1 st Stage	0,0 bar

Use keys 3 to 6 in the Menu "Display I" to change between the displayed values.



Note

Pushing key 8 in the display menu "Display II" leads to the option "Pressure200/300" for compressors with 2 filling pressures. Displayed in field 3 of the display menu "Display I".



OPERATION AND FUNCTION

Display II (M270)

Pushing key 7 in the Selection Menu leads to Menu "Display II".

Display II:

Press.	Temp.
4: 0	C: 0
5: 0	D: 0
6: 0	E: 0
7: 0	F: 0
bar	°C
(M270)	Return : #

This display shows further customer specific pressure and temperature values.

Key # leads back to "Main Menu"

B

OPERATION AND FUNCTION

Settings Menu (M300)

Pushing key 3 in the Selection Menu leads to the Settings Menu.

Settings:	
Automatic	
2	Stop pressure
3	Restart Press.
Semi-Automatic	
4	Stop Pressure
9	Close
(M300)	Return : #

Key 2 leads to submenu „Set Stop Pressure“

Key 3 leads to submenu „Set Restart Pressure“

Key 4 leads to submenu „Set Stop Pressure“

Key 9 leads back to submenu "Selection"

Key # leads back to "Main Menu"

Use menu M700 to change between "Automatic" and "Semi-Automatic" mode.

Restart pressure can only be set in "Automatic Mode".

Prior to setting the pressure, start the safety valve test.



Attention during maintenance

During automatic mode, the compressor can automatically start by itself at any time, depending on the selected restart pressure (see "Set Restart Pressure" M330).



OPERATION AND FUNCTION

Set Stop Pressure - automatic mode (M320)

Only valid in automatic mode, see menu M700.

Set
Stop Pressure:
Actual: 330 bar
7 New Value:
>> XXX bar
4 (050,, 333)
8 Confirm
(M320) Return : #

Current restart pressure
Key 7 if restart pressure should be changed
XXX indicates modified stop pressure
Chooseable pressure range for restart pressure
Key 8 confirms new restart pressure
Key # leads back to "Main Menu"

B

Set Restart Pressure - automatic mode (M330)

Only valid in automatic mode, see menu M700.

Set
Restart Pressure:
Actual: 180 bar
7 New Value:
>> XXX bar
4 (030,, 310)
8 Confirm
(M330) Return : #

Current restart pressure
Key 7 if restart pressure should be changed
XXX indicates modified restart pressure
Chooseable pressure range for restart pressure
Key 8 confirms new restart pressure
Key # leads back to "Main Menu"

Set Stop Pressure - semi-automatic mode (M340)

Only valid in semi-automatic mode, see menu M700.

Set
Stop Pressure:
Actual: 180 bar
7 New Value:
>> XXX bar
4 (030,, 310)
8 Confirm
(M340) Return : #

Current stop pressure
Key 7 if stop pressure should be changed
XXX indicates modified stop pressure
Chooseable pressure range for stop pressure
Key 8 confirms new restart pressure
Key # leads back to "Main Menu"

OPERATION AND FUNCTION

Test Menu (M400)

Pushing key 4 in the Selection Menu leads to the Test Menu.

Test:	
2	Solenoids
3	Safety Valve
4	Test-Stop
9	Close
(M400)	Return : #

Key 2 leads to submenu "Test Solenoids"

Key 3 leads to submenu "Test Safety Valve"

Key 4 leads to submenu "Test Stop without Venting"

Key 9 leads back to submenu "Selection"

Key # leads back to "Main Menu"

B

Test Solenoids (M420)

Pushing key 2 in the Selection Menu leads to Submenu "Test Solenoids".

Test Solenoids	
3	open
7	close
9	Close
(M420)	Return : #

Key 3 opens solenoids

Key 7 closes solenoids

Key 9 leads back to submenu „Test“

Key # leads back to "Main Menu"



Note

This menu can not be left unless solenoids have been closed by key 7.

OPERATION AND FUNCTION

Test safety valve (M430)

Pushing key 3 in the Test Menu leads to Submenu "Test Safety Valve".



Note

Prior to starting the Test, close all filling connections (also connected filling panels if necessary). During this test, the compressor passes the selected stop pressure (see Menu M320) to test the correct function of the final pressure safety valve. This would limit the maximum operating over pressure of the unit in case of malfunction.

B

Test
Safety Valve

Close Filling Valves!

5 Start	0 Stop
9 Close	
(M430) Return : #	

Key 5 to start test Key 0 to stop test

Key 9 leads back to submenu „Test“

Key # leads back to "Main Menu"

Test stop without venting (M440)

Pushing key 4 in the Test Menu leads to Menu "Test Stop without Venting".



Note

This test is only operable when the compressor has been started with key 1. This test mainly checks the leak tightness of pressure vessels, pressurised pipes, safety valves and the compressor block.

Test
stop without venting:

5 Stop	
6 Vent	
Pressure	0
	bar
9 Close	
(M440) Return : #	

Key 5 stops compressor during test run

Key 6 vents compressor after leak search has been finished

Shows current filling pressure

Key 9 leads back to submenu „Test“

Key # leads back to "Main Menu"



OPERATION AND FUNCTION

Statistics Menu (M500)

Pushing key 5 in the Selection Menu leads to Submenu "Statistics".

Statistics	
Operation Hours:	0,0 h
Start cycles:	00
Max Press	000 bar
9 Close	
(M500) Return : #	

Total operation hours of compressor unit

Total number of compressor starts

Maximum working pressure of unit (set by safety valve test)

Key 9 leads back to submenu „Selection“

Key # leads back to "Main Menu"

Push key 5 to get information on which ECC software version is currently installed on your system (M505), i.e.: By pushing key 2, the total load cycles of the filter housing are being indicated.

B

OPERATION AND FUNCTION

Maintenance Menu (M600)

Pushing key 6 in the Selection Menu leads to the "Maintenance Menu".

Hours remaining		
Oil change	14 h	Shows remaining hours of listed components (i.e. next oil change in 14 hours,...)
Sinter filt	989 h	
Silencer	4989 h	
Valves	5989 h	
Oil filter	1000 h	
8 Change done		Key 8 leads to submenu "Receipt Maintenance"
9 Close		Key 9 leads back to submenu „Selection“
(M600) Return : #		Key # leads back to "Main Menu"

Remaining hours depend on the type. At the end of any remaining hours, the display indicates a warning message. Furthermore, the display informs about any possibly necessary spare parts with the corresponding L&W service part number.



Attention during maintenance

During automatic mode, the compressor can automatically start by itself at any time, depending on the selected restart pressure (see "Set Restart Pressure" M330).



OPERATION AND FUNCTION

Confirm Maintenance (M680)

Confirm Maintenance	
2	Oil change
3	Sinter filters
4	Silencer
5	Valves
6	Oil filter
(M680)	Return : #

Key 2 receipts oil change

Key 3 receipts change of sinter filters

Key 4 receipts change of silencer

Key 5 receipts change of valves

Key 6 receipts oil filter

Key # leads back to "Main Menu"

B

Display confirms any reset of "Hours remaining" with the following message:

Confirm Maintenance	
Operation Hours Meter Set	
9	Close
(M680)	Return : #

Key 9 leads back to submenu "Hours remaining"

Key # leads back to "Main Menu"

OPERATION AND FUNCTION

Operation Mode (M700)

Pushing key 7 in the Selection Menu leads to the menu "Operation Mode".

Activated modes are always displayed in bolt letters (above example: **Semi-Automatic**).

Further settings can be made in the Settings Menu (M300).

B

Betriebsart:	
2	Automatic
3	Semi-Automatic
4	bar /mpa
5	Sprache
9	Close
(M700)	Return : #

Key 2 activates automatic mode

Key 3 activates semi-automatic mode

Key 4 selects between bar and MPa (optional)

Key 5 leads to the "Language Menu"

Key 9 leads back to submenu „Selection“

Key # leads back to "Main Menu"

Language Menu (M750)

Language Menu	
2	German
3	English
4	French
5	Spanish
6	Dutch
7	Language II
(M750)	Return : #

Key 7 optional language (e.g. Chinese)

Key # leads back to "Main Menu"

OPERATION AND FUNCTION

Adjusting Display Backlight

The brightness of the display can be adjusted with an adjusting screw on the back of the control.

Software Update

Software updates can only be carried out by L&W. To carry out an update, the device has to be send to the L&W service.

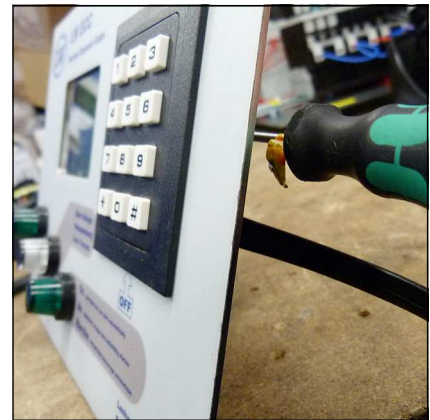

Adjust brightness

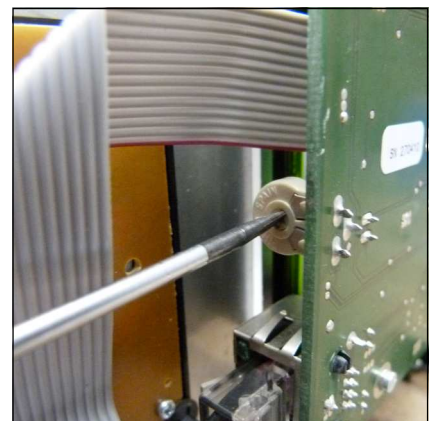

Adjust brightness

B

SPARE PART LISTS

Best.-Nr. / Order No.	Benennung	Description
002141	1. Stufe Druckaufnehmer 0-10 bar	1st stage pressure sensor 0-10 bar
002142	2. Stufe Druckaufnehmer 0-60 bar	2nd stage pressure sensor 0-60 bar
003888	3. Stufe Druckaufnehmer 0-100 bar	3rd stage pressure sensor 0-100 bar
002143	Endstufe Druckaufnehmer 0-400 bar	Final stage pressure sensor 0-400 bar
006890	Druckaufnehmer 420 bar Version 0-600 bar	Pressure sensor 420 bar version 0-600 bar
004840	Öldruckaufnehmer 0-6 bar	Oil pressure sensor 0-6 bar
006912	Öltemperatursensor	Oil temperature sensor
003501	Zylinderkopf - Temperatursensor	Cylinderhead temperature sensor

B



002141 / 002142 / 002143 / 003888 / 004840
Druckaufnehmer / Pressure sensor



006890 - Druckaufnehmer 420 bar /
Pressure sensor 420 bar



006912 - Öltemperatursensor
Oil temperature sensor



003501 - Zylinderkopf - Temperatursensor
Cylinderhead temperature sensor



LENHARDT & WAGNER GMBH

B

Manufacturer in terms of 97/23/EC

The full name and address of the manufacturer is:

Lenhardt & Wagner GmbH

An der Tuchbleiche 39
68623 Hüttenfeld / Germany

Phone: +49 (0) 62 56 - 85 88 0 - 0

Fax: +49 (0) 62 56 - 85 88 0 - 14

E-Mail: service@lw-compressors.com

Internet: www.lw-compressors.com





**ERSATZTEILLISTEN / SPARE PARTS LISTS
DETAILANSICHTEN / DETAILED VIEWS**

C



Inhaltsverzeichnis - Table of Contents

Ersatzteillisten / Spare Parts Lists	3
Ansaugfilter - Air Intake Filter	7
Kurbelwelle - Crankshaft	9
Kolben 1. Stufe - Piston 1st Stage	11
Kolben 2. Stufe - Piston 2nd Stage	13
Ersatzteillisten / Spare Parts Lists	15
Saug+Druckventil 1. Stufe - In+Outlet Valve 1st Stage	18
Saug+Druckventil 2. Stufe - In+Outlet Valve 2nd Stage	19
Saug+Druckventil 3. Stufe - In+Outlet Valve 3rd Stage	20
Saug+Druckventil 4. Stufe - In+Outlet Valve 4th Stage	21
Ölpumpe - Oil Pump	22
Motor - Motor	24
Kupplung - Coupling	26
Lüfterrad - Fan	28
Wasserabscheider 1. Stufe - Water Separator 1st Stage	29
Wasserabscheider 2. Stufe - Water Separator 2nd Stage	32
Wasserabscheider 3. Stufe - Water Separator 3rd Stage	35
Ölabscheider - Oil Separator	38
Ölverteilerblock - Oil Manifold Block	40
Filter 0,8l - Filter 0.8ltr	42
Magnetventil 1. Stufe - Solenoid Valve 1st Stage	44
Magnetventil 2. Stufe - Solenoid Valve 2nd Stage	46
Magnetventil 3. Stufe - Solenoid Valve 3rd Stage	48
Pneumatisches Kondensatventil - Pneumatic Condensate Valve	50
Kondensatablasseinheit - Condensate Drain Unit	52



Inhaltsverzeichnis - Table of Contents

Kühler 1. Stufe - Cooler 1st Stage	54
Kühler 2. Stufe - Cooler 2nd Stage	56
Kühler 3. Stufe - Cooler 3rd Stage.....	58
Kühler 4. Stufe - Cooler 4th Stage.....	60

Kompressorblock / Compressor Block

Best.-Nr. / Order No.	Benennung	Description
000257	Obere Ventildichtung, 1. Stufe	Upper Valve Gasket, Paper, 1st
000796	Verschraubung WE10LRCFX	Elbow Connection WE10LRCFX
000816	Verschraubung, GE15LR3/8KEGCFX	Connection, GE15LR3/8KEGCFX
000977	Zylinderschraube M12x70mm DIN912 8.8 ZN	Allen Bolt M12x70mm DIN912 8.8 ZN
000979	Zylinderschraube, M12x90mm DIN912 8.8 ZN	Allen Bolt, M12x90mm DIN912 8.8 ZN
001040	Zylinderschraube M8x20mm DIN912 8.8 ZN	Allen Screw M8x20mm DIN912 8.8 ZN
001043	Zylinderschraube, M8x35mm DIN912 8.8 ZN	Allen Screw, M8x35mm DIN912 8.8 ZN
001057	Zylinderschraube, M8x65mm DIN912 8.8 ZN	Allen Bolt, M8x65mm DIN912 8.8 ZN
001088	Zylinderschraube, M10x60mm DIN912 8.8 ZN	Hexagon Bolt, M10x60mm DIN912 8.8 ZN
001134	Sechskantschraube, M12x35mm DIN933 8.8 ZN	Hexagon Screw, M12x35mm DIN933 8.8 ZN
001158	Mutter, M8 DIN934 ZN	Nut, M8 DIN934 ZN
001165	Mutter, M12 DIN934 ZN	Nut, M12 DIN934 ZN
001181	U-Scheibe , A8 DIN125 ZN	Washer, A8 DIN125 ZN
001186	O-Ring, 59,69 x 5,33 N552-90	O-Ring, 59,69 x 5,33 N552-90
001191	U-Scheibe A12 DIN125 ZN	Washer A12 DIN125 ZN
001193	Schnorr-Scheibe, S12 N0110 ZN	Clamp Washer, S12 N0110 ZN
001197	Federring, A14 DIN127 ZN	Spring Washer, A14 DIN127 ZN
001215	USIT-Ring, Ø8,7XØ14X1mm	U-Sit Seal Ring, Ø8,7XØ14X1mm
001296	O-Ring 69,52x2,62 NBR90	O-Ring 69,52x2,62 NBR90
001323	CU-Ring, Ø10 x 16 x 2mm, DIN7603A	Copper Seal Ring, Ø10 x 16 x 2mm, DIN7603A
001326	CU-Ring, Ø12 X 18 X 1,5mm, DIN7603A	Copper Seal Ring, Ø12 X 18 X 1,5mm, DIN7603A
001362	Sicherungsring, I 72 DIN472	Circlip, I 72 DIN472
001618	Hauptlager, 6311-C3	Main Bearing, 6311-C3
001619	Ölschleuderring	Oil Thrower Ring



ERSATZTEILLISTE / SPARE PART LIST

Kompressorblock / Compressor Block

Best.-Nr. / Order No.	Benennung	Description
001620	Lagerdeckel Kurbelgehäuse	Bearing Cover Cranksase
001621	Kurbelgehäuse	Crank Case
001622	Führungszylinder	Guide Cylinder
001636	Öleinfüllstopfen G1", inkl. Dichtring	Oil Filler Plug G1", c/w gasket
001637	Gleitlagerbuchse	Bush Bearing
001649	Schwungrad	Flywheel
001651	Sechskant Schraube, M14	Hexagon Bolt, M14
002688	Dichtung, Zylinderflansch	Gasket cylinder flange
002689	Zylinder, Ø135mm	Cylinder, Ø135mm
002690	Untere Ventildichtung, Ø141mm für Ventil 000936	Lower gasket, Ø141 for valve 000936
002691	Obere Ventildichtung, für Ventil 000936	Upper gasket, for valve 000936
002692	Ventilkopf	Valve head
002693	Zylinder, Ø70mm	Cylinder, Ø70mm
002694	Untere Dichtung	Upper gasket
002696	Kompressionszylinder, Ø32mm, gehärtet	Compression cylinder, Ø32mm, hardened
002697	Ventilkopf	Valve head
002698	Kompressionszylinder, Ø16mm, gehärtet	Compression cylinder, Ø16mm, hardened
002704	Sicherungsring I 120 DIN 472	Circlip I 120 DIN 472
002706	Dichtung Kurbelgehäusedeckel	Gasket crankcase cover
002707	Sicherungsring,, A55 DIN 471	Circlip, A55 DIN 471
002710	Unterlegscheibe	Washer
002713	Kurbelgehäuseentlüftungsstutzen	Crank shaft ventilation union
002714	Radial-Wellendichtring 55x72x7	Shaft seal 55x72x7
002716	Stiftschraube	Stud screw
003286	Ölschauglas	Oil Level Indicator
008013	Ventilkopf für Ventil Ø102mm, 2x G3/4"	Valve Head for Valve Ø102mm, 2x G3/4"



ERSATZTEILLISTE / SPARE PART LIST

Kompressorblock / Compressor Block

Best.-Nr. / Order No.	Benennung	Description
	BG Kurbelwelle	Ass: Crankshaft
	BG: Ventil 1.Stufe	Ass: Valve 1 st stage
	BG: Ventil 2.Stufe	Ass: Valve 2 nd stage
	BG: Ventil 3.Stufe	Ass: Valve 3 rd stage
	BG: Ventil 4.Stufe	Ass: Valve 4 th stage
	BG: Kolben 1.Stufe	Ass: Piston 1 st stage
	BG: Kolben 2.Stufe	Ass: Piston 2 nd stage
	BG: Kolben 3.Stufe	Ass: Piston 3 rd stage
	BG: Kolben 4.Stufe	Ass: Piston 4 th stage
	BG: Ölpumpe	Ass: Oil Pump

C

DETAILANSICHT / DETAILED VIEW

Kompressorblock / Compressor Block

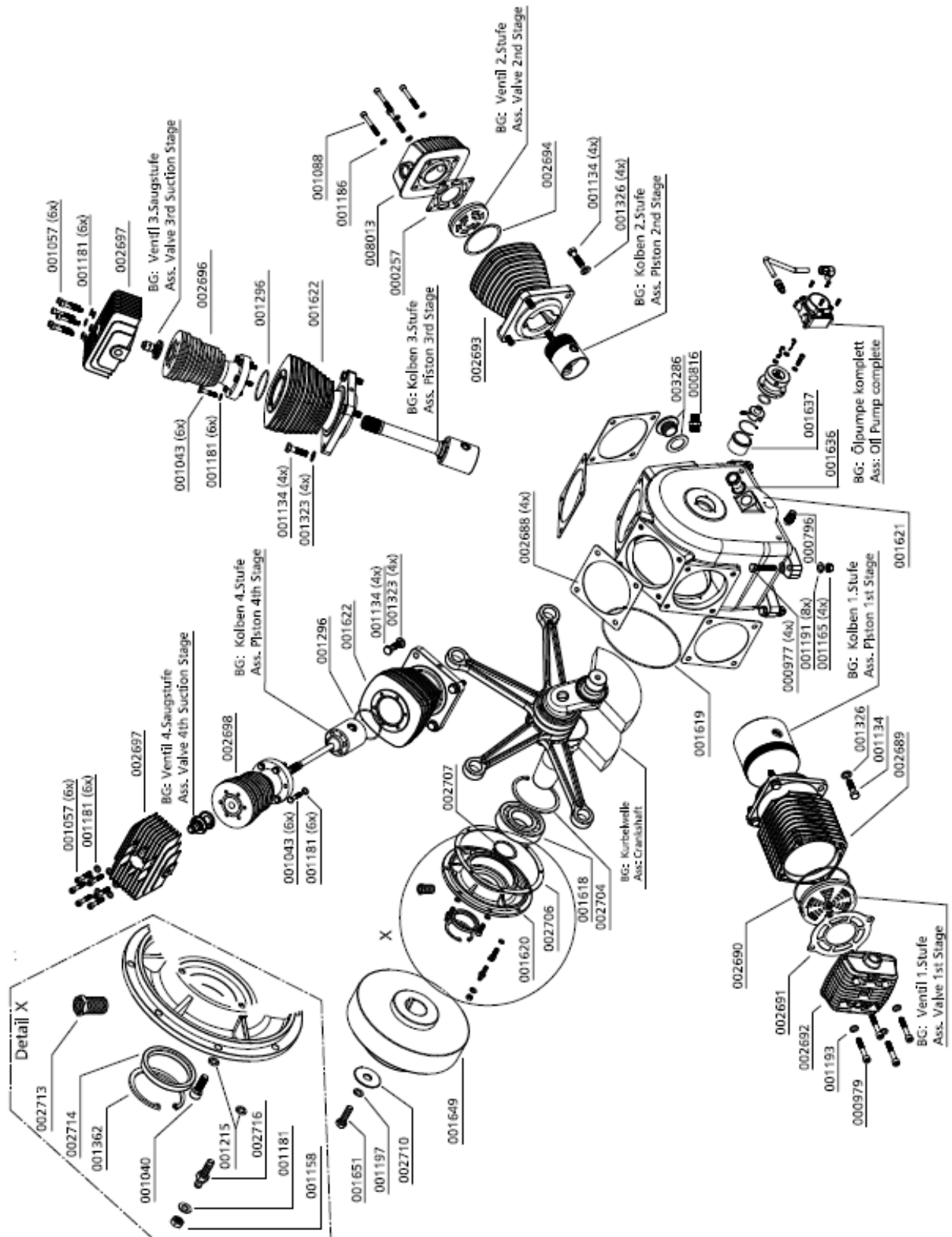



ERSATZTEILLISTE / SPARE PART LIST

Ansaugfilter / Intake Filter

Best.-Nr. / Order No.	Benennung	Description
001041	Zylinderschraube, M8x25mm DIN912 8.8 ZN	Allen Screw, M8x25mm DIN912 8.8 ZN
001154	Verschraubung, G30SCFXC	Connection, G30SCFXC
001181	U-Scheibe, A8 DIN125 ZN	Washer, A8 DIN125 ZN
001316	O-Ring Ansaugfiltergehäuse, 186x3 NBR70	O-Ring, intake filter housing, 186x3 NBR70
002661	Ansaugfiltergehäuse	Intake filter housing
002662	Ansaugfilterpatrone	Intake filter cartridge
002663	Deckel Ansaugfilter	Cover intake filter

C

DETAILANSICHT / DETAILED VIEW

Ansaugfilter / Intake Filter

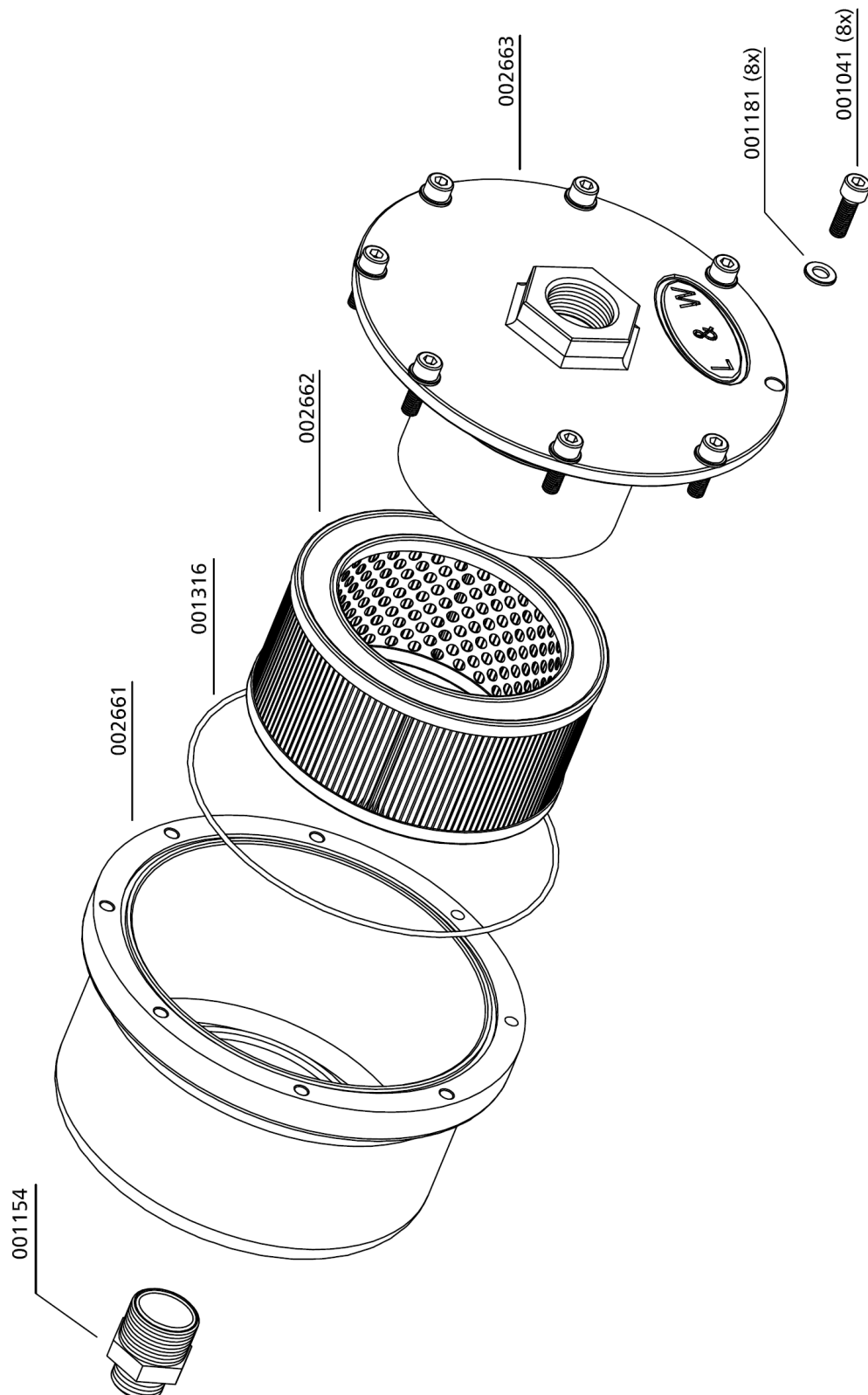



ERSATZTEILLISTE / SPARE PART LIST

Kurbelwelle / Crankshaft

Best.-Nr. / Order No.	Benennung	Description
001197	Federring, A14 DIN127 ZN	Spring Washer, A14 DIN127 ZN
001213	Passfeder, A12X8X50mm DIN6885	Woodruff Key, A12X8X50mm DIN6885
001562	Anlaufscheibe hinten	Thrust Washer back side
002668	Kurbelwelle	Crank shaft
002669	Gegengewicht Kurbelwelle	Counter weight, crank shaft
002670	Zylinderschraube, M14x80mm DIN 912 ZN	Screw, M14x80mm DIN 912 ZN
002671	Pleuel, Ø 80 mm, Ø 26 mm, 240 mm	Conrod, Ø 80 mm, Ø 26 mm, 240 mm
002672	Pleuel, Ø80 mm, Ø28 mm, 240 mm	Conrod, Ø80 mm, Ø28 mm, 240 mm
002675	Sicherungsring, A 80 DIN 471	Circlip, A 80 DIN 471
004176	Anlaufscheibe vordere	Thrust Washer front side
004809	Ölpumpenmitnehmerschraube	Drive bolt
006698	Nadellager, oberes Pleuellager, Ø30x22x16mm NK2216	Nadellager, small end, Ø30x22x16mm NK2216

C

DETAILANSICHT / DETAILED VIEW

Kurbelwelle / Crankshaft

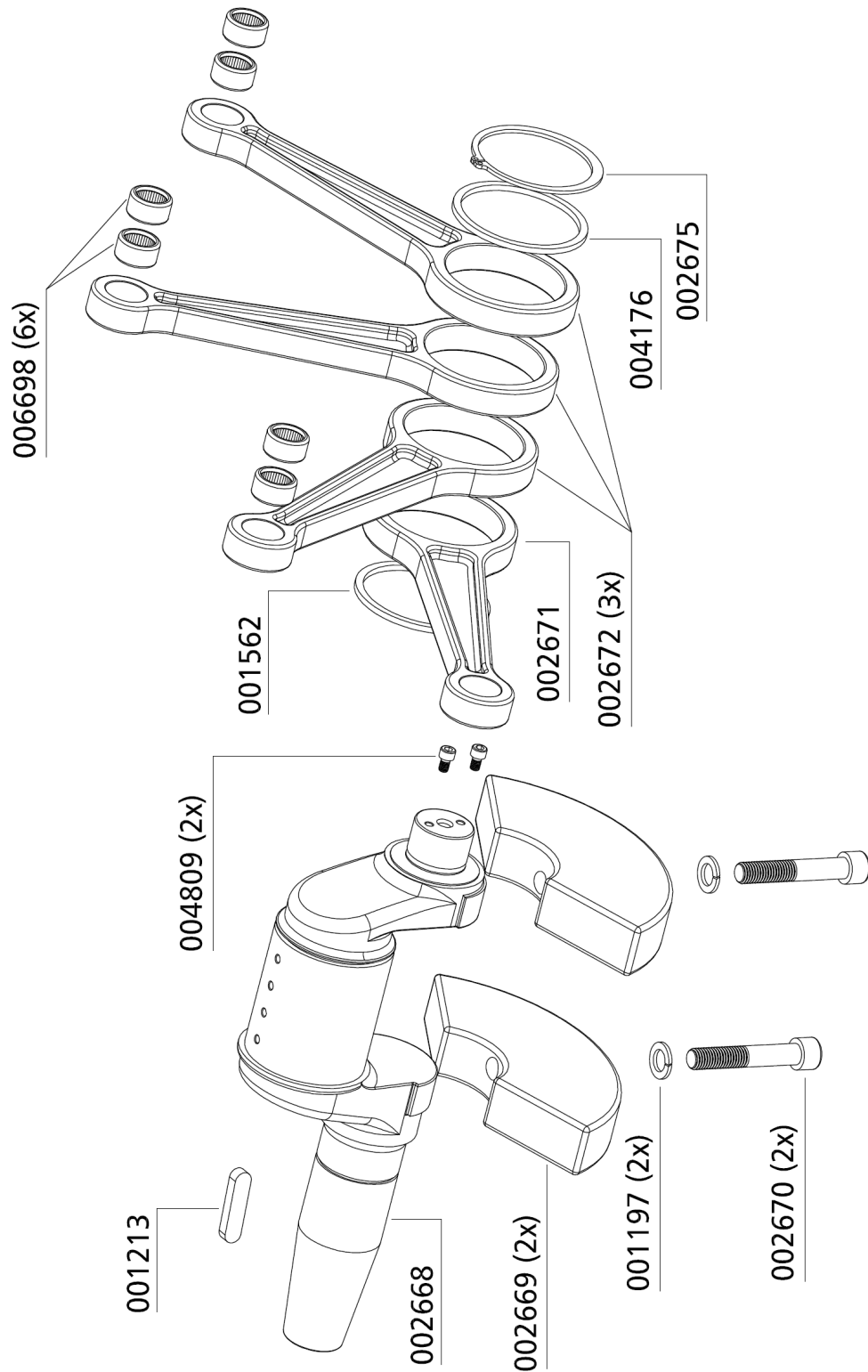

C



ERSATZTEILLISTE / SPARE PART LIST

Kolben 1. Stufe / Piston 1st Stage

Best.-Nr. / Order No.	Benennung	Description
002676	Kolben, Ø135mm (ohne Ringe u. Bol-	Piston, Ø135mm (w/o Rings and pins)
002677	Kolbenbolzen 1. Stufe, Ø135mm	Piston pin 1st stage, Ø135mm
002678	Kolbenringe, Ø135mm	Set of piston rings, Ø135mm
003571	Sicherungsring, I 26 DIN 472	Circlip, I 26 DIN 472

C

DETAILANSICHT / DETAILED VIEW

Kolben 1. Stufe / Piston 1st Stage

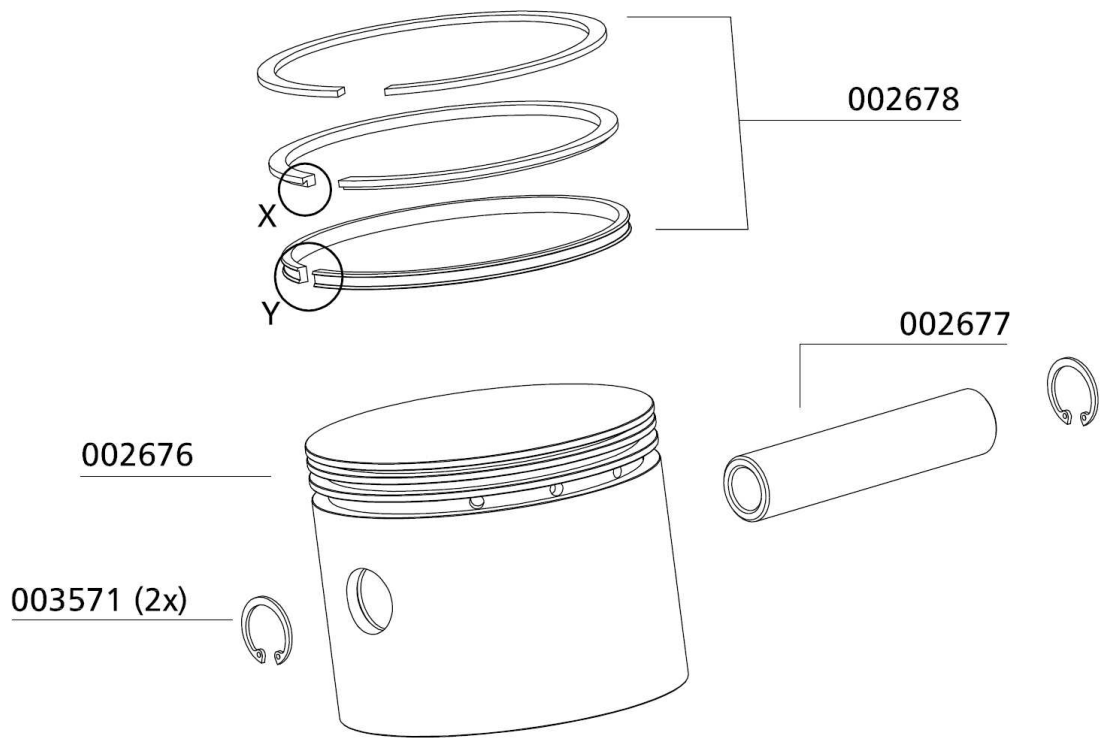

X (5:1)

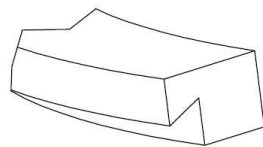

Y (5:1)

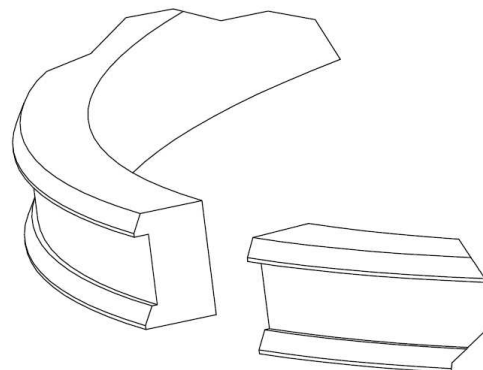



ERSATZTEILLISTE / SPARE PART LIST

Kolben 2. Stufe / Piston 2nd Stage

Best.-Nr. / Order No.	Benennung	Description
001356	Sicherungsring, I 22 DIN472	Circlip, I 22 DIN472
002679	Kolben Ø70mm - Alu, ohne Bolzen & Ringe	Piston Ø70mm - alloy (w/o Rings and pins)
002680	Kolbenbolzen Führungskolben, Ø22 mm	Piston Pin, Guide Piston, Ø22 mm
006158	Kolbenringe Satz, Ø70mm (unbeschichtet)	Set of piston rings, Ø70mm (uncoated)

C

DETAILANSICHT / DETAILED VIEW

Kolben 2. Stufe / Piston 2nd Stage

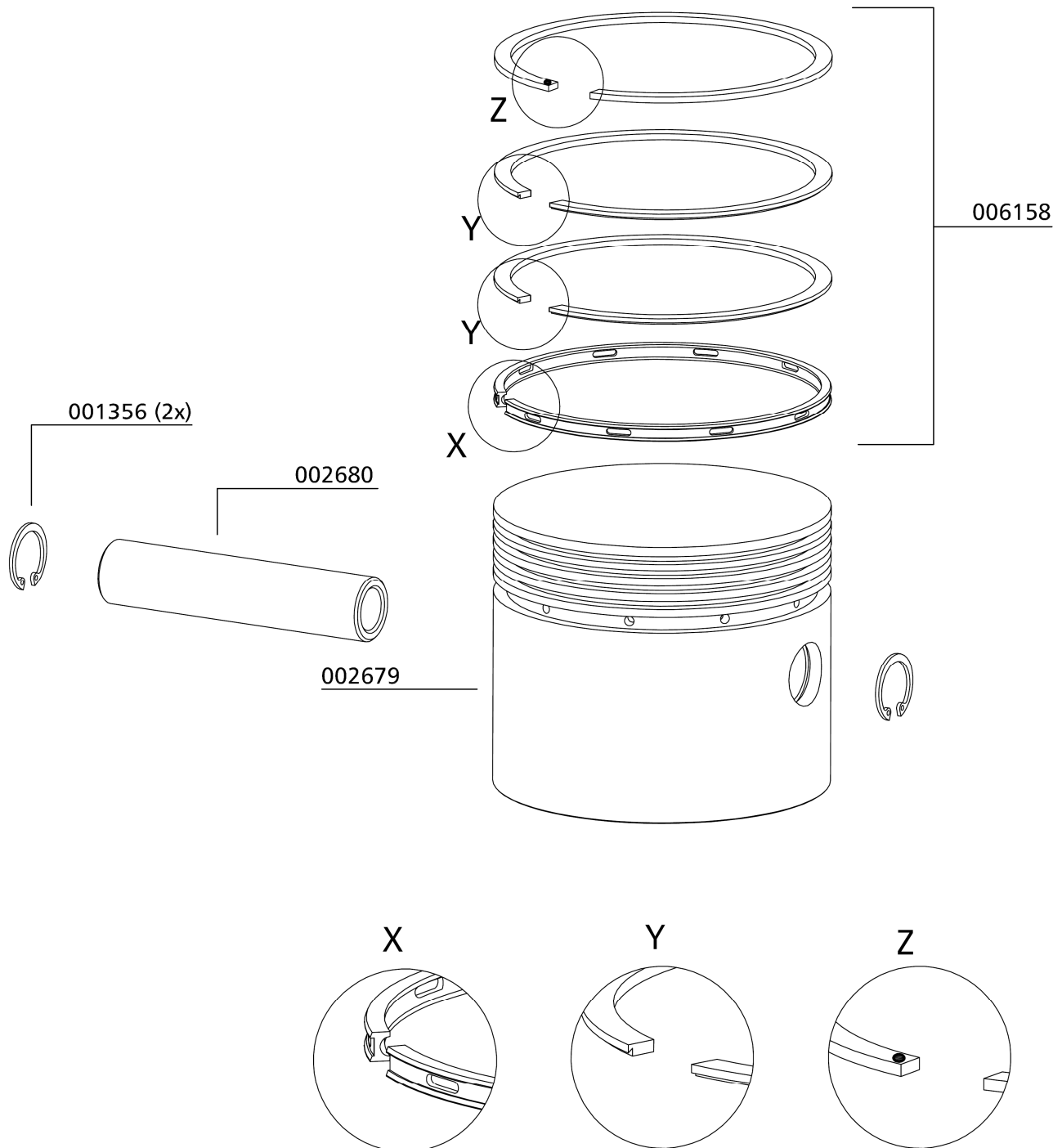



ERSATZTEILLISTE / SPARE PART LIST

Kolben 3. Stufe / Piston 3rd Stage

Best.-Nr. / Order No.	Benennung	Description
001075	Senkschraube, M6x20mm DIN7991 10.9	Counter Sunk Screw, M6x20mm DIN7991 10.9
001356	Sicherungsring, I 22 DIN472	Circlip, I 22 DIN472
001547	Haltesegment Führungskolben	Clamp Guide Piston
002682	Führungskolben 3.+4. Stufe	Guide Piston 3rd + 4th Stage
002683	Kolbenbolzen Führungskolben 3.+4. Stufe, Ø22 x 62mm	Piston pin, Guide Piston, Ø22 x 62mm
002684	Kompressionskolben, Ø32mm Stahlausführung	Guide Piston 3rd + 4th Stage, Ø32mm, Steel version
002686	Kolbenringe, Ø32mm , Satz/8Stk., beschichtet	Set of Piston Rings, Ø32mm, coated 8pcs

C

DETAILANSICHT / DETAILED VIEW

Kolben 3. Stufe / Piston 3rd Stage

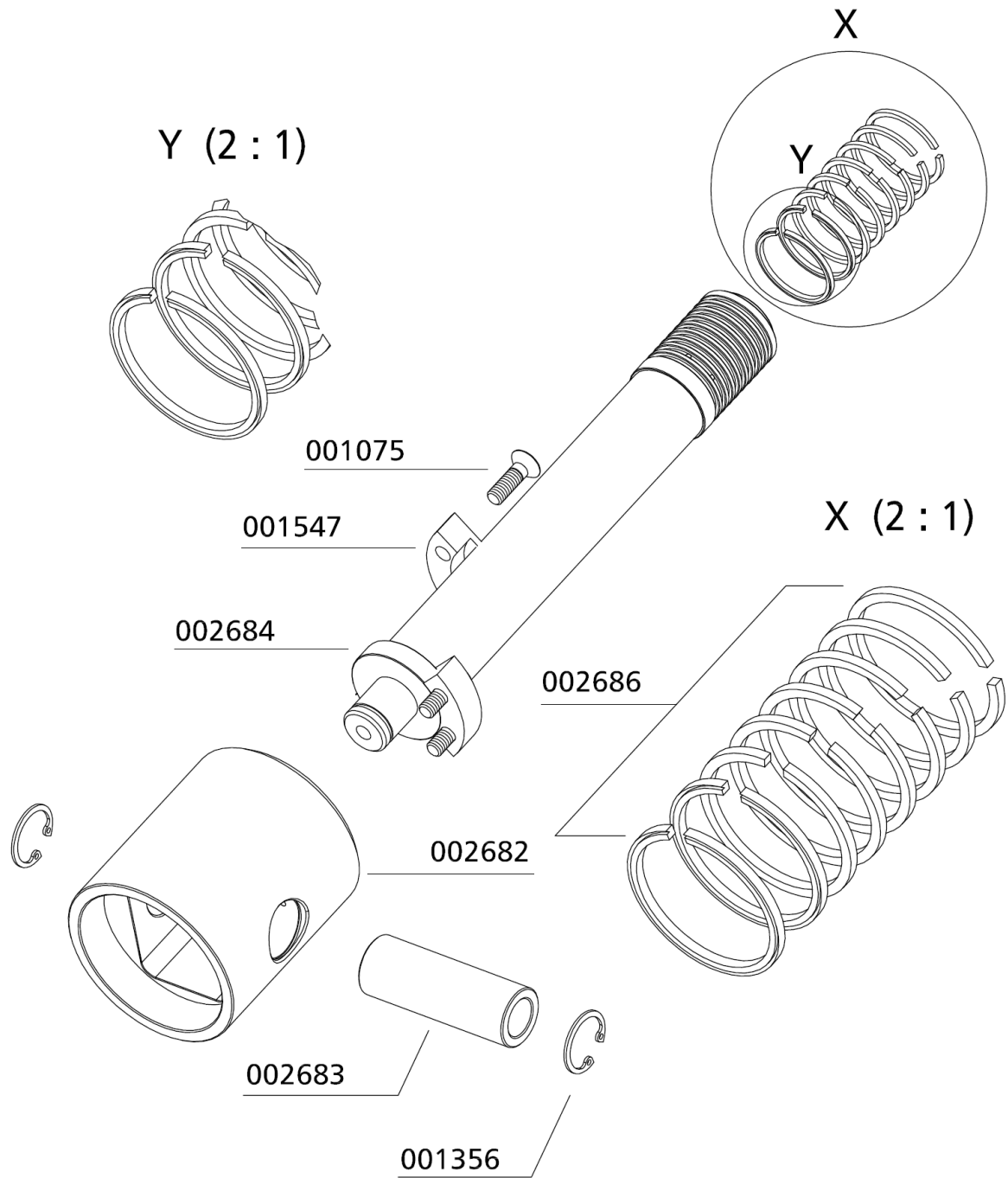

C



ERSATZTEILLISTE / SPARE PART LIST

Kolben 4. Stufe / Piston 4th Stage

Best.-Nr. / Order No.	Benennung	Description
001075	Senkschraube, M6x20mm DIN7991 10.9	Counter Sunk Screw, M6x20mm DIN7991 10.9
001356	Sicherungsring, I 22 DIN472	Circlip, I 22 DIN472
001547	Haltesegment Führungskolben	Clamp Guide Piston
002682	Führungskolben 3.+4. Stufe	Guide Piston 3rd + 4th Stage
002683	Kolbenbolzen Führungskolben, 3.+4. Stufe, Ø22 x 62mm	Piston pin, Guide Piston, 3rd + 4th Stage, Ø22 x 62mm
002685	Kompressionskolben, Ø16mm, Stahlauführung	Piston, 3rd Stage, Ø32mm, Steel Version
002687	Kolbenringe Satz, Ø16mm, beschichtet	Set of Piston Rings, Ø16mm, coated

C

ERSATZTEILLISTE / SPARE PART LIST

Saug- und Druckventil 1. Stufe / In- and Outlet Valve 1st Stage

Best.-Nr. / Order No.	Benennung	Description
000936	Saug- Druckventil, Ø141 mm, 1. Stufe	In-&Outlet Valve, Ø141 mm, 1st Stage

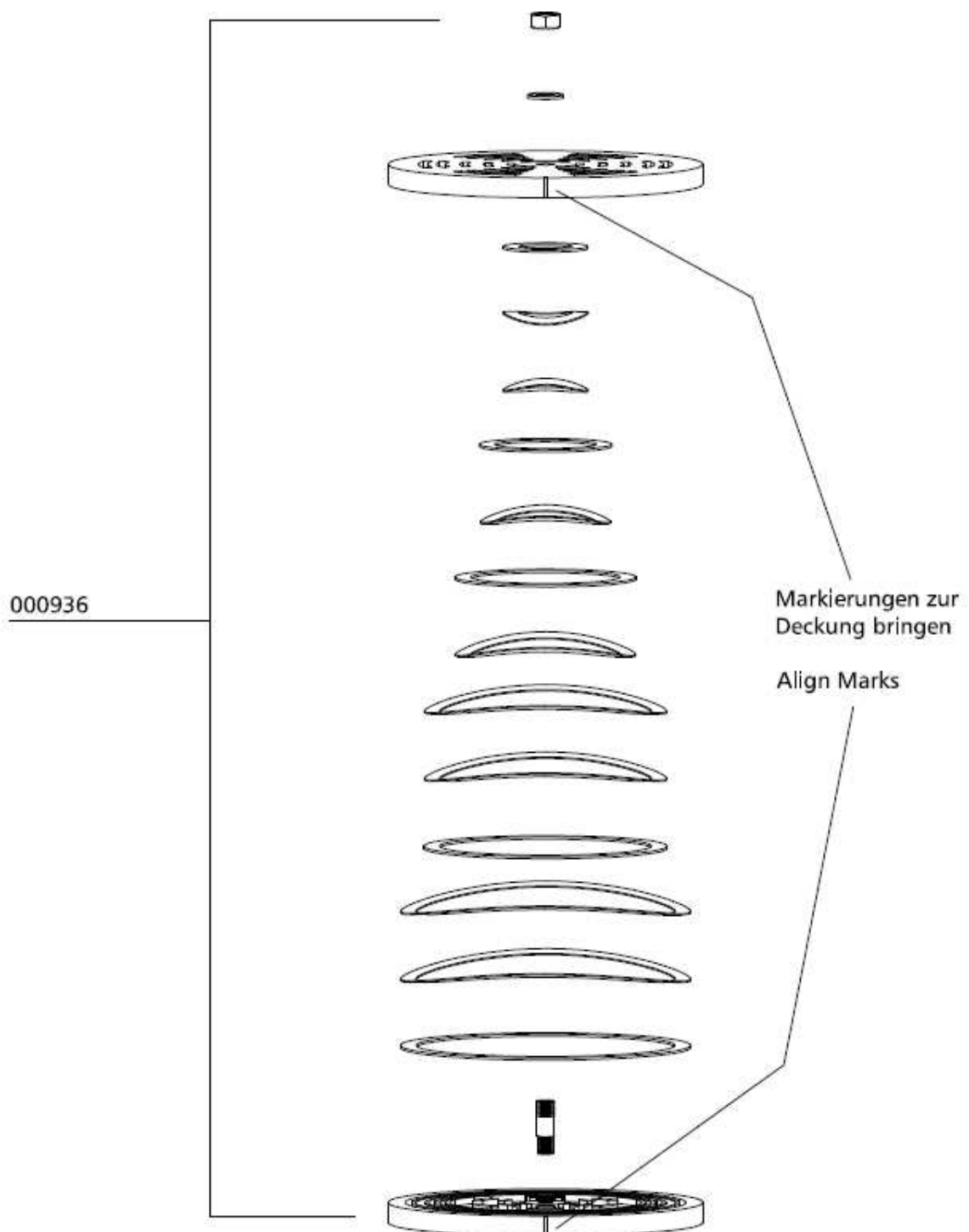

ERSATZTEILLISTE / SPARE PART LIST

Saug- und Druckventil 2. Stufe / In- and Outlet Valve 2nd Stage

Best.-Nr. / Order No.	Benennung	Description
007827	Saug- Druckventil, Ø102mm	In-&Outlet Valve, Ø102mm

007827
(komplett / complete)

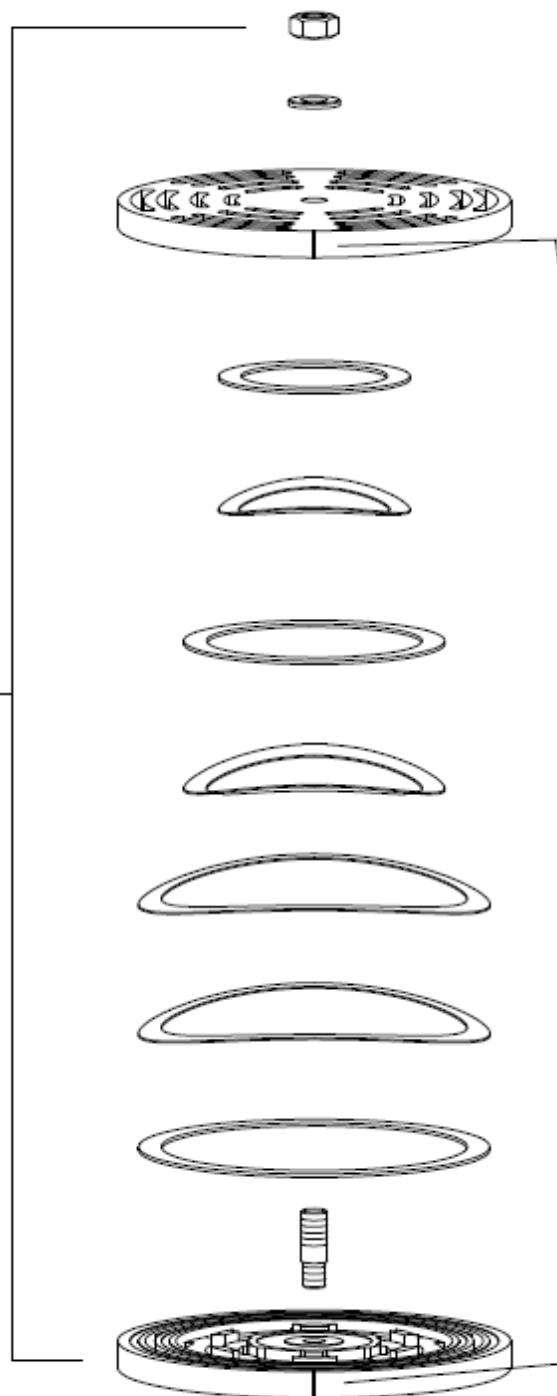

Markierungen zur
Deckung bringen!

Align Marks!

C

ERSATZTEILLISTE / SPARE PART LIST

Saug- und Druckventil 3. Stufe / In- and Outlet Valve 3rd Stage

Best.-Nr. / Order No.	Benennung	Description
000526	Saug-Druckventil, ohne Aludichtungen	In- & Outlet Valve w/o gaskets
000532	Ventildichtung, Saug-& Druckventil un-	Lower Valve Gasket
000541	Saug- u. Druckventil oben, Al	Upper Alloy Seal Ring
000551	Saug-Druckventil, komplett	In- & Outlet Valve, complete

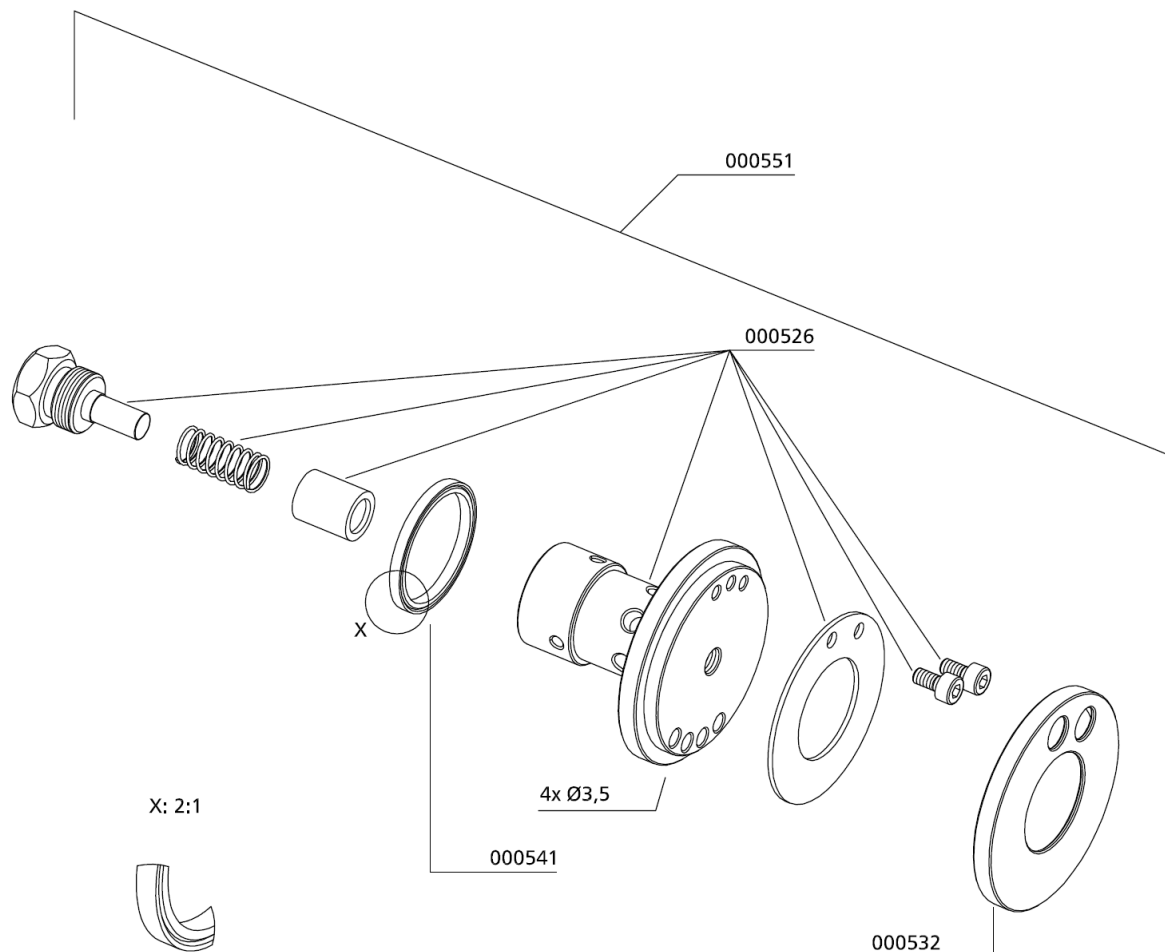

Saug- und Druckventil 4. Stufe / In- and Outlet Valve 4th Stage

Best.-Nr. / Order No.	Benennung	Description
000525	Saug-Druckventil, ohne Aludichtung	In- & Outlet Valve w/o gaskets
000531	Ventildichtung, Saug-& Druckventil un-	Lower Valve Gasket
000541	Dichtung Saug- u. Druckventil oben, Al	Upper Alloy Seal Ring
000552	Saug-Druckventil , komplett	In- & Outlet Valve, complete

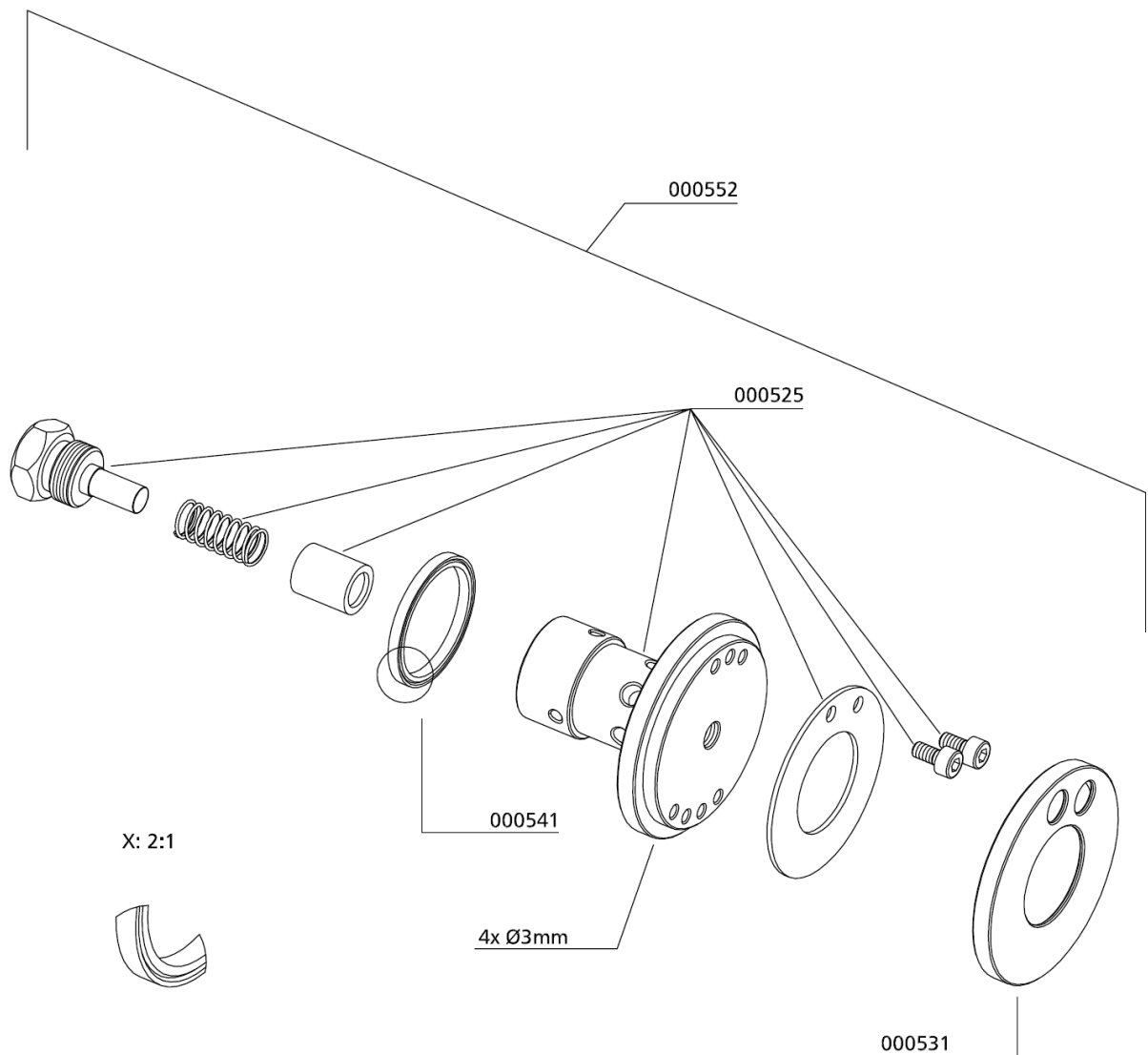

Ölpumpe / Oil Pump

Best.-Nr. / Order No.	Benennung	Description
000208	Ölpumpenantriebsflansch	Drive Flange Oil Pump
000498	U-Scheibe DIN 125 A6	Washer DIN 125 A6
000712	Verschraubung GE06LR1/4CFX	Connection GE06LR1/4CFX
000716	Verschraubung TE G1/8" / 6L	Connection TE G1/8" / 6L
000732	Mutter M06LCFX	Union M06LCFX
000733	Schneidring PSR06FX	Olive Seal PSR06FX
000759	Verschraubung WE 08 LL R 1/8"	Elbow connection WE 08 LL R 1/8"
000783	Verschraubung GE10L - R1/4"	Straight Connection GE10L - R1/4"
000958	Gewindestift, Madenschraube M8x16mm DIN914, 5.8 ZN	Worm Screw M8x16mm DIN914, 5.8 ZN
001014	Gewindestift mit Zapfen M6X16mm DIN915	Allen Screw with Pin M6X16mm DIN915
001021	Zylinderschraube M5x40mm DIN912 8.8 ZN	Allen Bolt M5x40mm DIN912 8.8 ZN
001029	Zylinderschraube M6x20mm DIN912 8.8 ZN	Allen Bolt M6x20mm DIN912 8.8 ZN
001152	Stopfmutter M5 DIN934 ZN	Lock Nut M5 DIN934 ZN
001176	U-Scheibe A5 DIN125 ZN	Washer A5 DIN125 ZN
001525	Druckschalter, 0,5 - 5 bar	Oil Pressure Switch, 0,5 - 5 bar
002340	O-Ring Ölpumpenflansch 32,2x3 NBR70	O-Ring 32,2x3 NBR70
002619	Rohr, Kurbelgehäuse-->Oelpump	Pipe, crankcase -> oil pump
002620	Rohr, Ölpumpe / Druckschalter	Pipe, Oil Pump / Pressure Switch
002395	Verschlusskegel VK6	Locking cone VK6
002665	Halter Öldruckschalter	Bracket oil pressure switch
004204	Oelpumpenhalteflansch	Oil pump flange
005797	Schneidring PSR 08 LL X	Olive Seal PSR 08 LL X
005798	Mutter M08LLCFX	Nut M08LLCFX
006496	Ölpumpe, kompl.	Oil Pump

DETAILANSICHT / DETAILED VIEW

Ölpumpe / Oil Pump

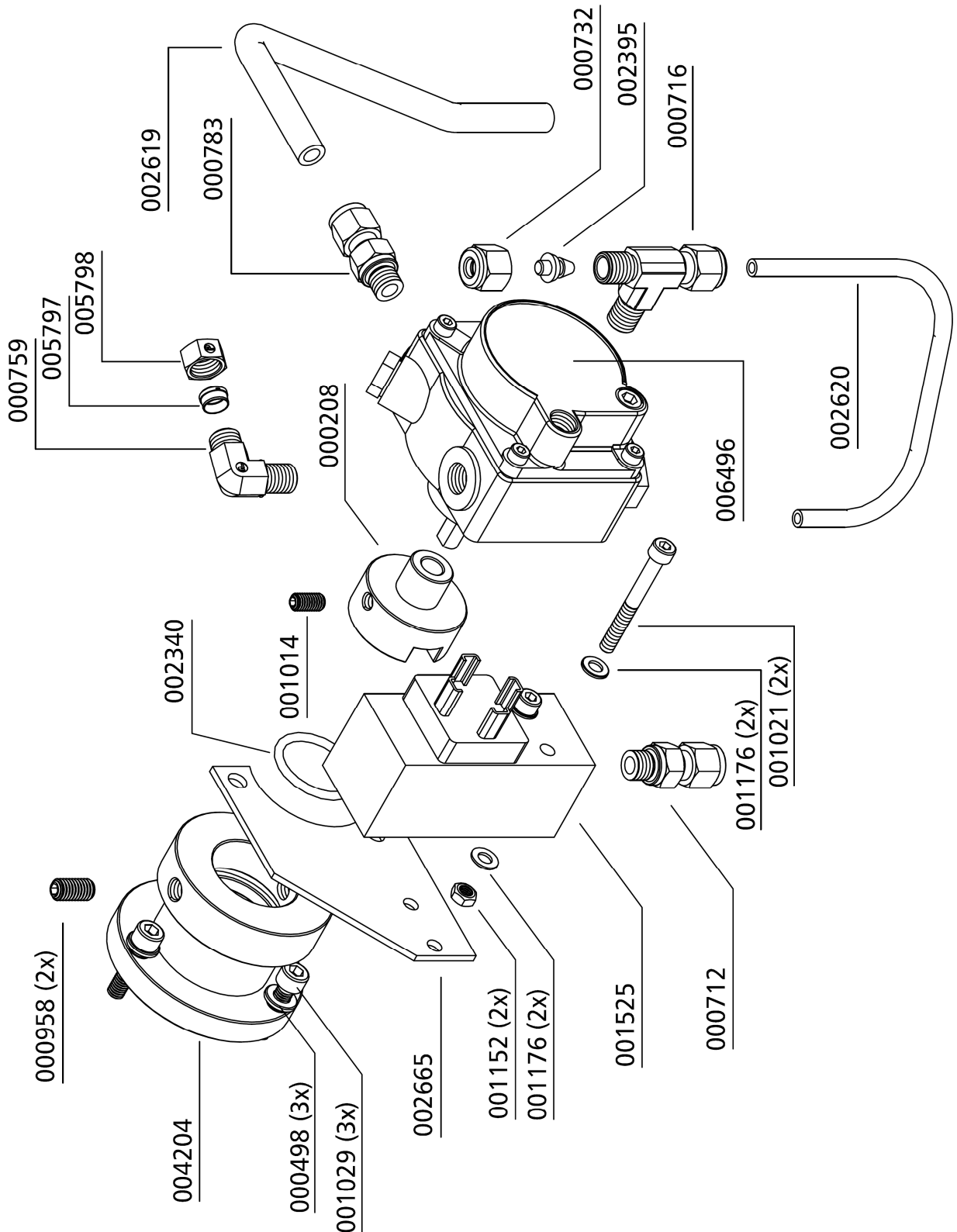



ERSATZTEILLISTE / SPARE PART LIST

Motor / Motor

Best.-Nr. / Order No.	Benennung	Description
001564	Passfeder, A20x12x130, LW 1300 E 45/55kW	Woodruff Key, A20x12x130, LW 1300 E 45/55kW
001571	Antriebsmotor 75kW, ATEX	Drive Motor 75kW, ATEX
001582	Passfeder, LW 1300 E 75kW	Woodruff Key, LW 1300 E 75kW
002726	Passfeder, LW 1300 E 37kW	Woodruff Key, LW 1300 E 37kW
003491	Passfeder, A20x12x130, LW 1300 E 30kW	Woodruff Key, A20x12x130, LW 1300 E 30kW
005394	Antriebsmotor 30kW, ATEX	Drive motor 30kW, ATEX
006018	Antriebsmotor 37kW, ATEX	Drive motor 37kW, ATEX
006208	Antriebsmotor 55kW, ATEX	Drive motor 55kW, ATEX
006209	Antriebsmotor 45kW, ATEX	Drive motor 45kW, ATEX

C

DETAILANSICHT / DETAILED VIEW

Motor / Motor

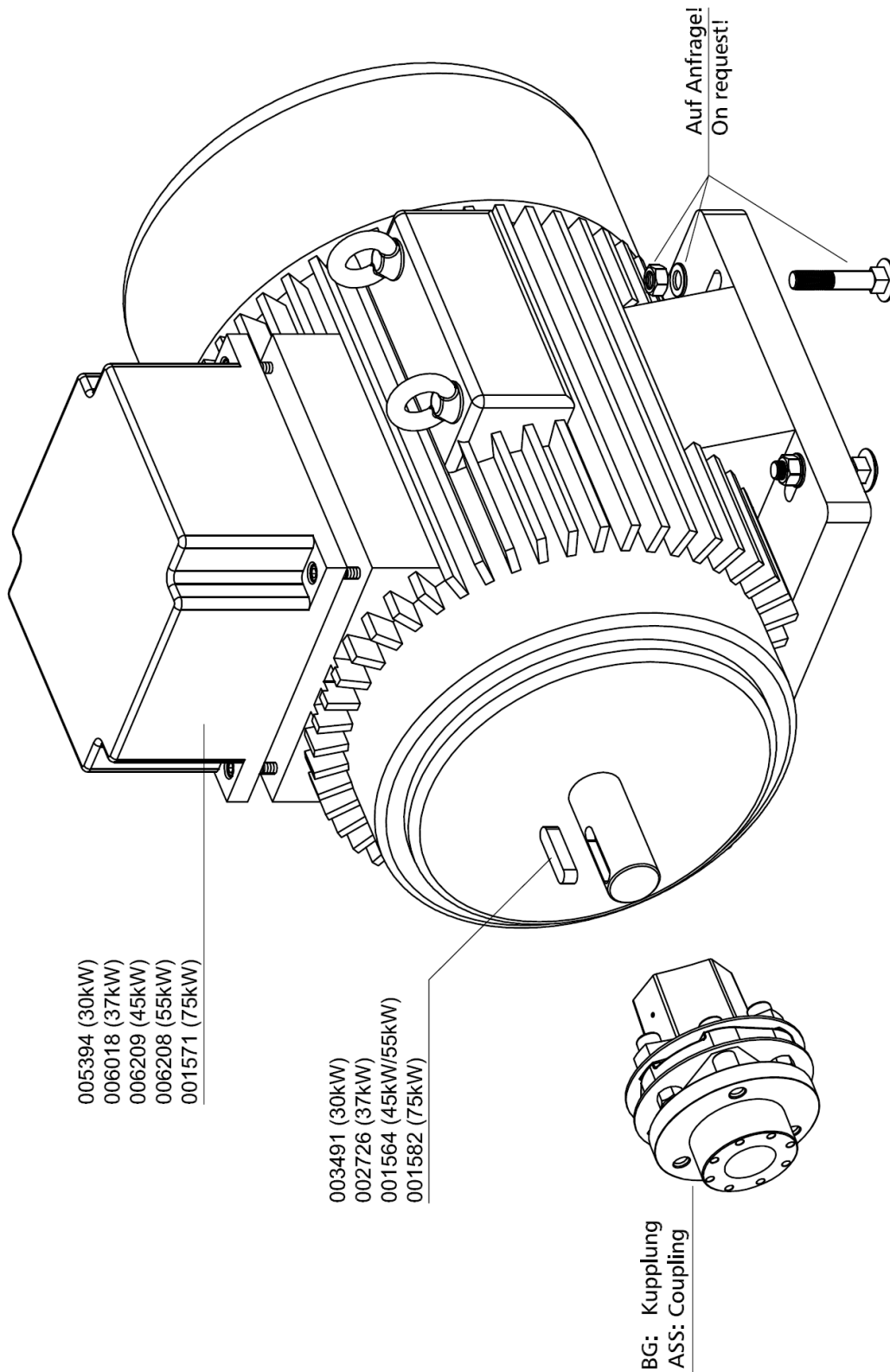

C



ERSATZTEILLISTE / SPARE PART LIST

Kupplung / Coupling

Best.-Nr. / Order No.	Benennung	Description
000959	Gewindestift	Worm Screw
004995	Kupplungsscheibe	Coupling disk
005063	Adapterscheibe Gummikupplung, (8x M12)	Adapter flange rubber coupling, (8x M12)
005299	Motorflansch f. Gummikupplung, Ø65 mm	Motor Flange for Clutch, Ø65 mm
005391	Motorflansch f. Gummikupplung, Ø60 mm	Motor Flange for Clutch, Ø60 mm
005392	Motorflansch f. Gummikupplung, Ø75 mm	Motor Flange for Clutch, Ø75 mm
005882	Unterlegblech Gummikupplung	Base Plates
006648	Schraubensatz	Bolt Set
006844	Adapterscheibe Gummikupplung	Adapter flange rubber coupling
006894	Motorflansch f. Gummikupplung Ø80 mm	Motor Flange for Clutch Ø80 mm

C

DETAILANSICHT / DETAILED VIEW

Kupplung / Coupling

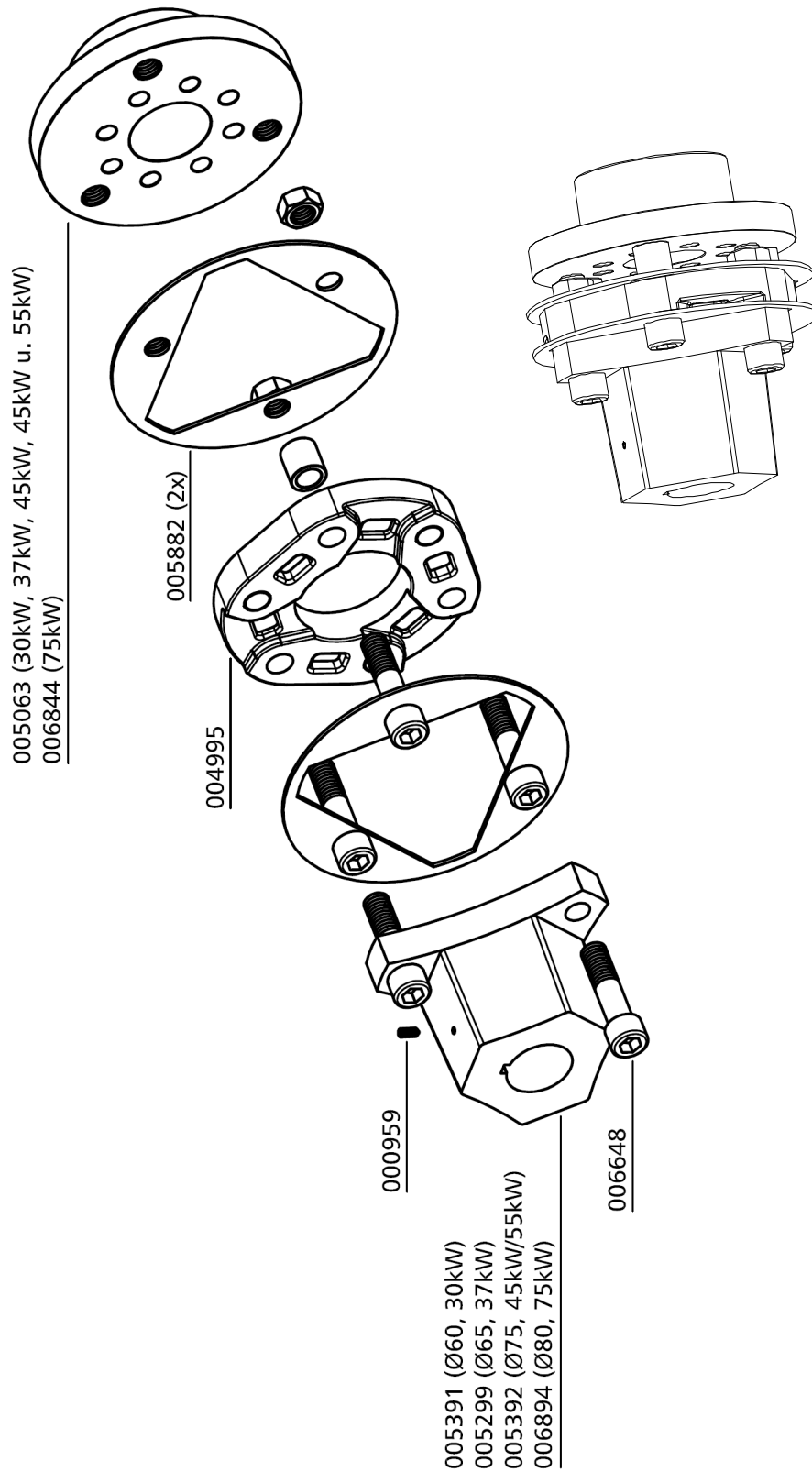

C

ERSATZTEILLISTE / SPARE PART LIST

Lüfterrad / Fan

Best.-Nr. / Order No.	Benennung	Description
004251	Ventilatorflügelblatt, 8/16-Blatt Nabe,	Cooling Fan, Blade 8/16, ATEX
004252	Lüfterrad kpl., 16 Blatt	Fan wheel, Blade 16

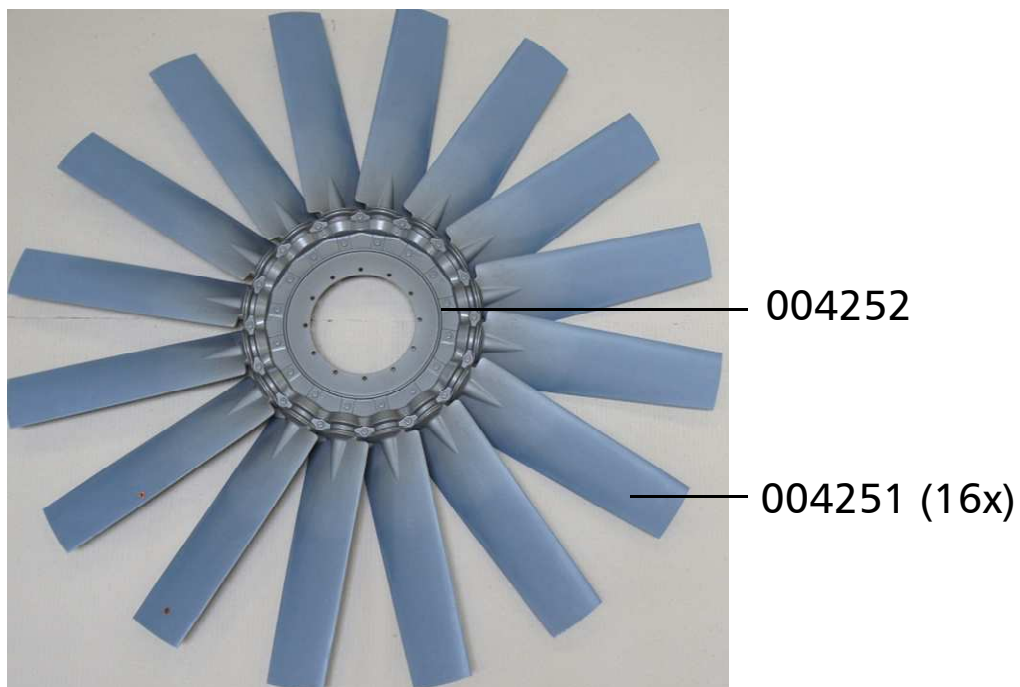

C

Wasserabscheider 1. Stufe / Water Separator 1st Stage

Best.-Nr. / Order No.	Benennung	Description
000220	Sicherheitsventil G3/8", 8 bar	Safety Valve G3/8", 8 bar
000391	U-Sit Ring	Seal Ring U-Sit
000645	Manometer, glyzeringefüllt, 0-10 bar Ø 63mm	Pressure Gauge, glycerine, 0-10 bar Ø 63mm
000738	Verschraubung, GE08LRFCX	Connection, GE08LRFCX
000761	Verschraubung, WE08LRFCX	Elbow Connection, WE08LRFCX
000773	Verschraubung	Connection
000777	Dichtring für Manometerverschraubung, DK11/4CFX	Seal Ring for Pressure Gauge, DK11/4CFX
000837	Verschlussstopfen VSTI R1/8" ED	Plug VSTI R1/8" ED
000838	Verschlussstopfen VSTIR1/4EDCF	Plug VSTIR1/4EDCF
000861	Schneidring, PSR 18LX	Olive Seal, PSR 18LX
000862	Mutter, M18LCFX	Union Nut, M18LCFX
000863	Winkelverschraubung, WE18L-R1/2" A3C	Elbow Connection, WE18L-R1/2" A3C
000876	Verschraubung, GE28L/1"R CFX	Connection, GE28L/1"R CFX
000877	Verschraubung, EVW28LOMDCF	Connection, EVW28LOMDCF
000880	Überwurfmutter, M28LCFX	Union Nut 28L, M28LCFX
000881	Schneidring, PSR28LX	Olive Seal, PSR28LX
000918	Reduzierung, RI1X1/2CFX	Reducer, RI1X1/2CFX
000997	Zylinderschraube M6x100mm DIN912 8.8 ZN	Allen Bolt M6x100mm DIN912 8.8 ZN
001132	Sechskantschraube M12x25mm DIN933 8.8 ZN	Hexagon Screw M12x25mm DIN933 8.8 ZN
001159	Stopfmutter M8 DIN985 ZN	Lock Nut M8 M8 DIN985 ZN
001181	U-Scheibe A8 DIN125 ZN	Washer A8 DIN125 ZN
001191	U-Scheibe A12 DIN125 ZN	Washer A12 DIN125 ZN
001214	USIT-Ring, Ø6,7xØ11x1mm	U-Sit Seal Ring, Ø6,7xØ11x1mm
001297	O-Ring 70 x 3 NBR70	O-Ring 70 x 3 NBR70
001306	O-Ring 90 x 3 NBR70	O-Ring 90 x 3 NBR70
001311	O-Ring, 114,02 x 1,78 NBR70	O-Ring, 114,02 x 1,78 NBR70
002646	Klemmring, Wasserabscheider	Ring, Water Separator



ERSATZTEILLISTE / SPARE PART LIST

Wasserabscheider 1. Stufe / Water Separator 1st Stage

Best.-Nr. / Order No.	Benennung	Description
002647	Rohr, Wasserabscheider	Pipe, Water Separator
002648	Drallscheibe, Wasserabscheider	Swirl Disk, Water Separator
002649	Sinterfilter, Wasserabscheider	Sintered Filter, Water Separator
002650	Abweiser, Wasserabscheider	Deflector, Water Separator
002651	Halteteller, Wasserabscheider	Holding Plate, Water Separator
002652	Oberteil Wasserabscheider 1. Stufe	Upper part water separator
002653	Deckel, Wasserabscheider	Cover, Water Separaptor
002914	Sinterfilter, Wasserabscheidersockel	Sintered Filter, Water Separator Base
003348	Filterverschraubung, Wasserabscheider	Connector, for Sintered Filter
003590	Gewindebolzen, Wasserabscheider	Threaded bolt, water separator

C

DETAILANSICHT / DETAILED VIEW

Wasserabscheider 1. Stufe / Water Separator 1st Stage

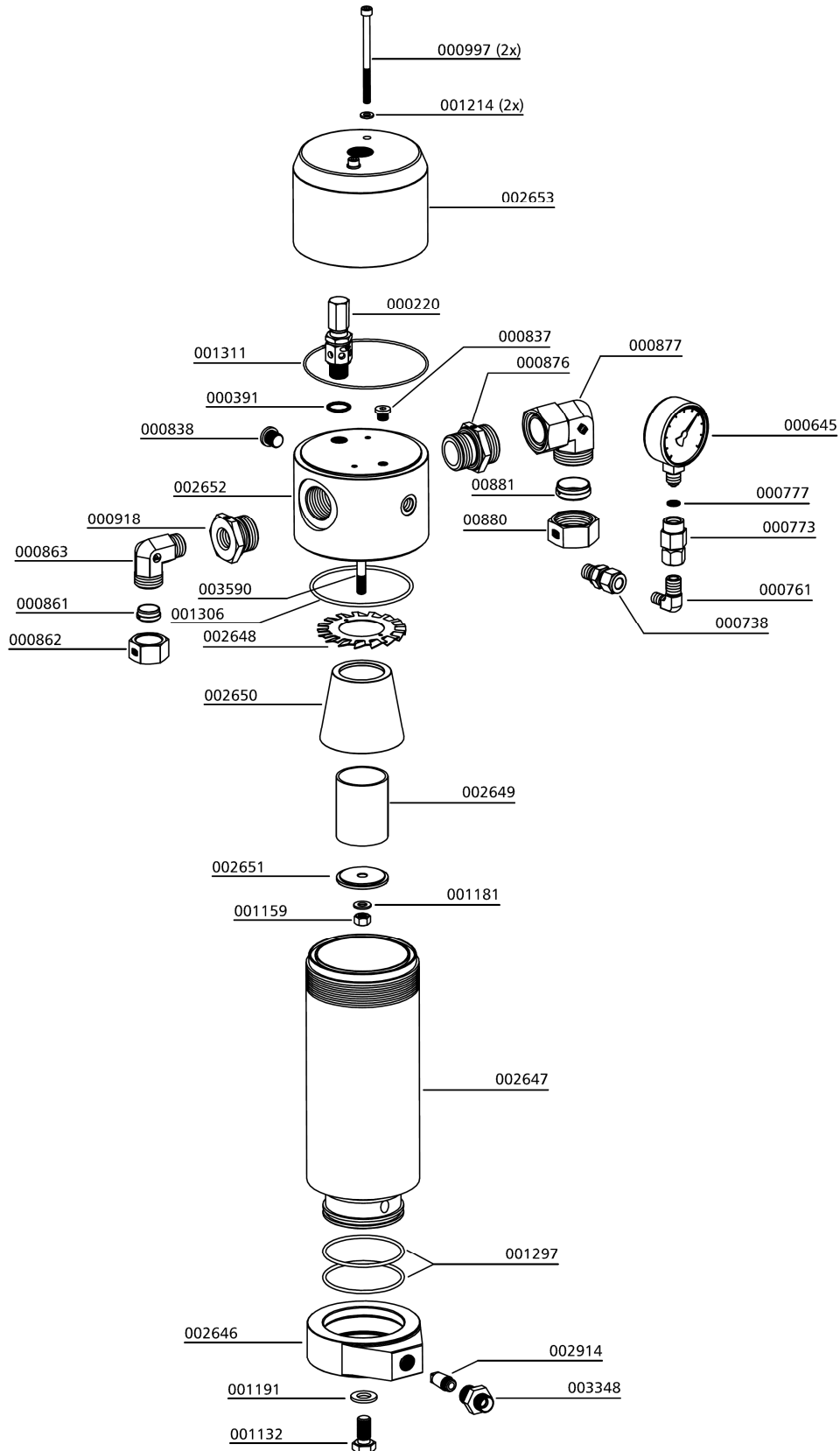

C

Wasserabscheider 2. Stufe / Water Separator 2nd Stage

Best.-Nr. / Order No.	Benennung	Description
000172	Halteteller Wasserabscheider	Plastic Air Deflector Water Separator
000173	Sinterfilter Wasserabscheider	Sintered Filter Water Separator
000174	Drallscheibe, Wasserabscheider	Twist Disk, Water separator
000176	Stiftschraube, Wasserabscheider	Treaded Stud, Water separator
000177	Trichter für Wasserabscheider	Water Deflector, Plastic
000390	Sicherheitsventil G3/8", 22 bar	Safety Valve G3/8", 22 bar
000391	U-Sit Ring	Seal Ring U-Sit
000564	Wasserabscheider-Behälter	Container Water Separator
000647	Manometer, glyzeringefüllt, 0-40 bar Ø63mm	Pressure Gauge, glycerine, 0-40 bar Ø63mm
000761	Verschraubung, WE08LRCFX	Elbow Connection, WE08LRCFX
000773	Verschraubung	Connection
000777	Dichtring für Manometerverschraubung, DKI1/4CFX	Seal Ring for Pressure Gauge, DKI1/4CFX
000807	Verschraubung, GE12LR1/2CFX	Connection, GE12LR1/2CFX
000813	Mutter, M12LCFX	Union Nut, M12LCFX
000814	Schneidring, PSR12LX	Olive Seal, PSR12LX
000837	Verschlussstopfen VSTI R1/8" ED	Plug VSTI R1/8" ED
000838	Verschlussstopfen VSTIR1/4EDCF	Plug VSTIR1/4EDCF
000861	Schneidring, PSR 18LX	Olive Seal, PSR 18LX
000862	Mutter, M18LCFX	Union Nut, M18LCFX
000863	Winkelverschraubung, WE18L-R1/2" A3C	Elbow Connection, WE18L-R1/2" A3C
000997	Zylinderschraube M6x100mm DIN912 8.8 ZN	Allen Bolt M6x100mm DIN912 8.8 ZN
001132	Sechskantschraube M12x25mm DIN933 8.8 ZN	Hexagon Screw M12x25mm DIN933 8.8 ZN
001156	Stopfmutter, M6 DIN985 ZN	Lock Nut, M6 DIN985 ZN
001191	U-Scheibe A12 DIN125 ZN	Washer A12 DIN125 ZN
001214	USIT-Ring, Ø6,7xØ11x1mm	U-Sit Seal Ring, Ø6,7xØ11x1mm
001272	O-Ring, 47 x 3 NBR70	O-Ring, 47 x 3 NBR70
001299	O-Ring, 72,75 x 1,78 NBR70	O-Ring, 72,75 x 1,78 NBR70



ERSATZTEILLISTE / SPARE PART LIST

Wasserabscheider 2. Stufe / Water Separator 2nd Stage

Best.-Nr. / Order No.	Benennung	Description
001511	Dichtkappe Wasserabscheider	Seal Cap Water Separator
002914	Sinterfilter, Wasserabscheidersockel	Sintered Filter, Water Separator Base
003347	Unterer Ring, Wasserabscheider	Base Ring, water separator
003348	Filterverschraubung, Wasserabscheider	Connector, for Sintered Filter
007134	Wasserabscheider - Oberteil	Top Cap Water Separator

C

DETAILANSICHT / DETAILED VIEW

Wasserabscheider 2. Stufe / Water Separator 2nd Stage

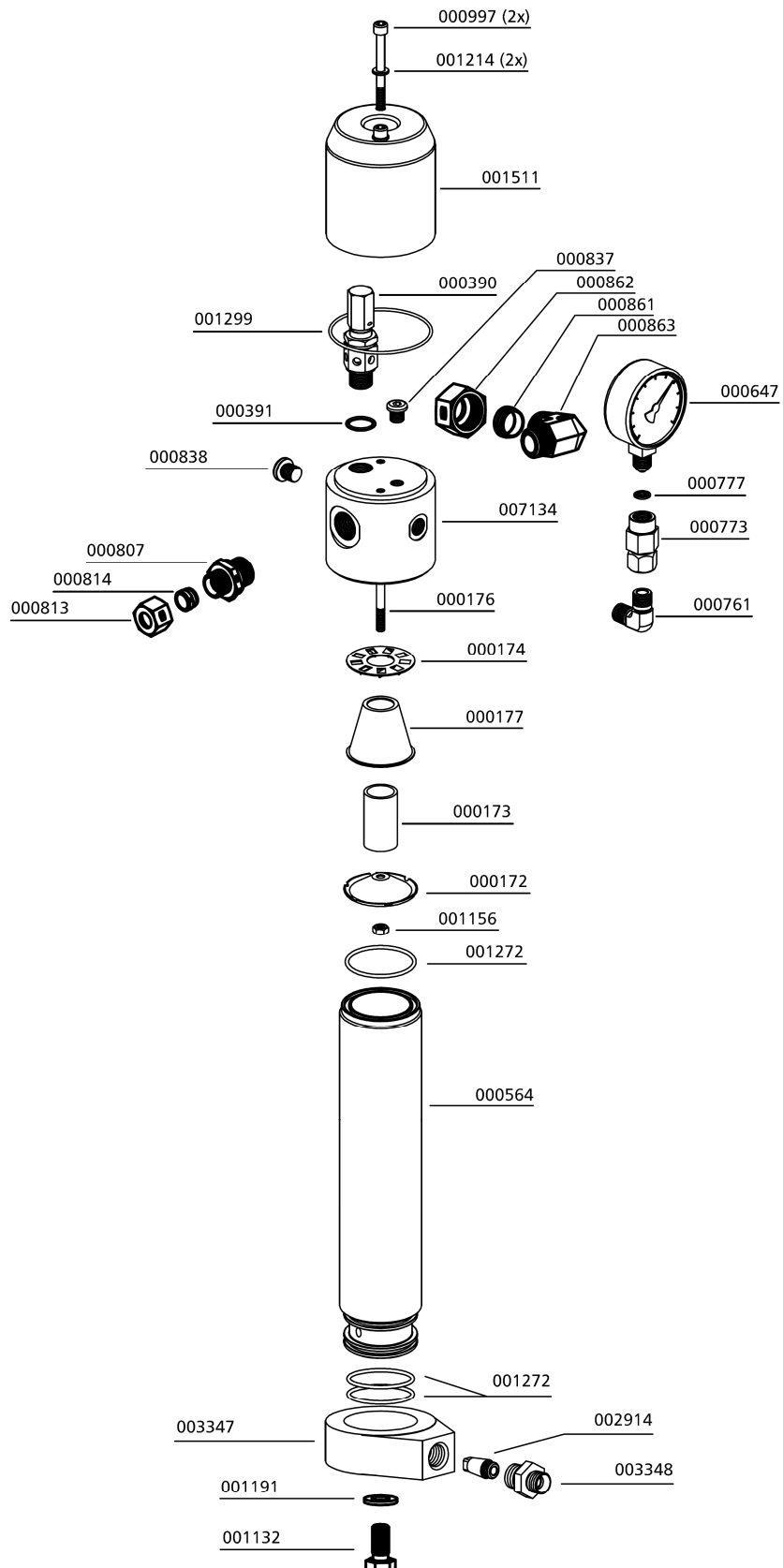

C

Wasserabscheider 3. Stufe / Water Separator 3rd Stage

Best.-Nr. / Order No.	Benennung	Description
000172	Halteteller Wasserabscheider	Plastic Air Deflector Water Separator
000173	Sinterfilter Wasserabscheider	Sintered Filter Water Separator
000174	Drallscheibe, Wasserabscheider	Twist Disk, Water separator
000176	Stiftschraube, Wasserabscheider	Treaded Stud, Water separator
000177	Trichter für Wasserabscheider	Water Deflector, Plastic
000381	Sicherheitsventil G3/8", 90 bar	Safety Valve G3/8", 90 bar
000391	U-Sit Ring	Seal Ring U-Sit
000564	Wasserabscheider-Behälter	Container Water Separator
000649	Manometer, glyzeringefüllt, 0-40 bar Ø63mm	Pressure Gauge, glycerine, 0-40 bar Ø63mm
000761	Verschraubung, WE08LRCFX	Elbow Connection, WE08LRCFX
000773	Verschraubung	Connection
000777	Dichtring für Manometerverschraubung, DKI1/4CFX	Seal Ring for Pressure Gauge, DKI1/4CFX
000796	Verschraubung, WE10LRCFX	Elbow Connection, WE10LRCFX
000801	Mutter M10LCFX	Union Nut M10LCFX
000802	Schneidring, PSR10LX	Olive Seal Ring, PSR10LX
000818	Verschraubung, GE15LRCFX	Connection, GE15LRCFX
000822	Mutter, M15LCFX	Union Nut, M15LCFX
000823	Schneidring, PSR15LX	Olive Seal, PSR15LX
000837	Verschlussstopfen VSTI R1/8" ED	Plug VSTI R1/8" ED
000838	Verschlussstopfen VSTIR1/4EDCF	Plug VSTIR1/4EDCF
000921	Reduzierung, R11/2X1/4CFX	Reducer, R11/2X1/4CFX
000997	Zylinderschraube M6x100mm DIN912 8.8 ZN	Allen Bolt M6x100mm DIN912 8.8 ZN
001132	Sechskantschraube M12x25mm DIN933 8.8 ZN	Hexagon Screw M12x25mm DIN933 8.8 ZN
001156	Stopfmutter, M6 DIN985 ZN	Lock Nut, M6 DIN985 ZN
001191	U-Scheibe A12 DIN125 ZN	Washer A12 DIN125 ZN
001214	USIT-Ring, Ø6,7xØ11x1mm	U-Sit Seal Ring, Ø6,7xØ11x1mm
001272	O-Ring, 47 x 3 NBR70	O-Ring, 47 x 3 NBR70
001299	O-Ring, 72,75 x 1,78 NBR70	O-Ring, 72,75 x 1,78 NBR70



ERSATZTEILLISTE / SPARE PART LIST

Wasserabscheider 3. Stufe / Water Separator 3rd Stage

Best.-Nr. / Order No.	Benennung	Description
001511	Dichtkappe Wasserabscheider	Seal Cap Water Separator
002914	Sinterfilter, Wasserabscheidersockel	Sintered Filter, Water Separator Base
003347	Unterer Ring, Wasserabscheider	Base Ring, water separator
003348	Filterverschraubung, Wasserabscheider	Connector, for Sintered Filter
007134	Wasserabscheider - Oberteil	Top Cap Water Separator

C

DETAILANSICHT / DETAILED VIEW

Wasserabscheider 3. Stufe / Water Separator 3rd Stage

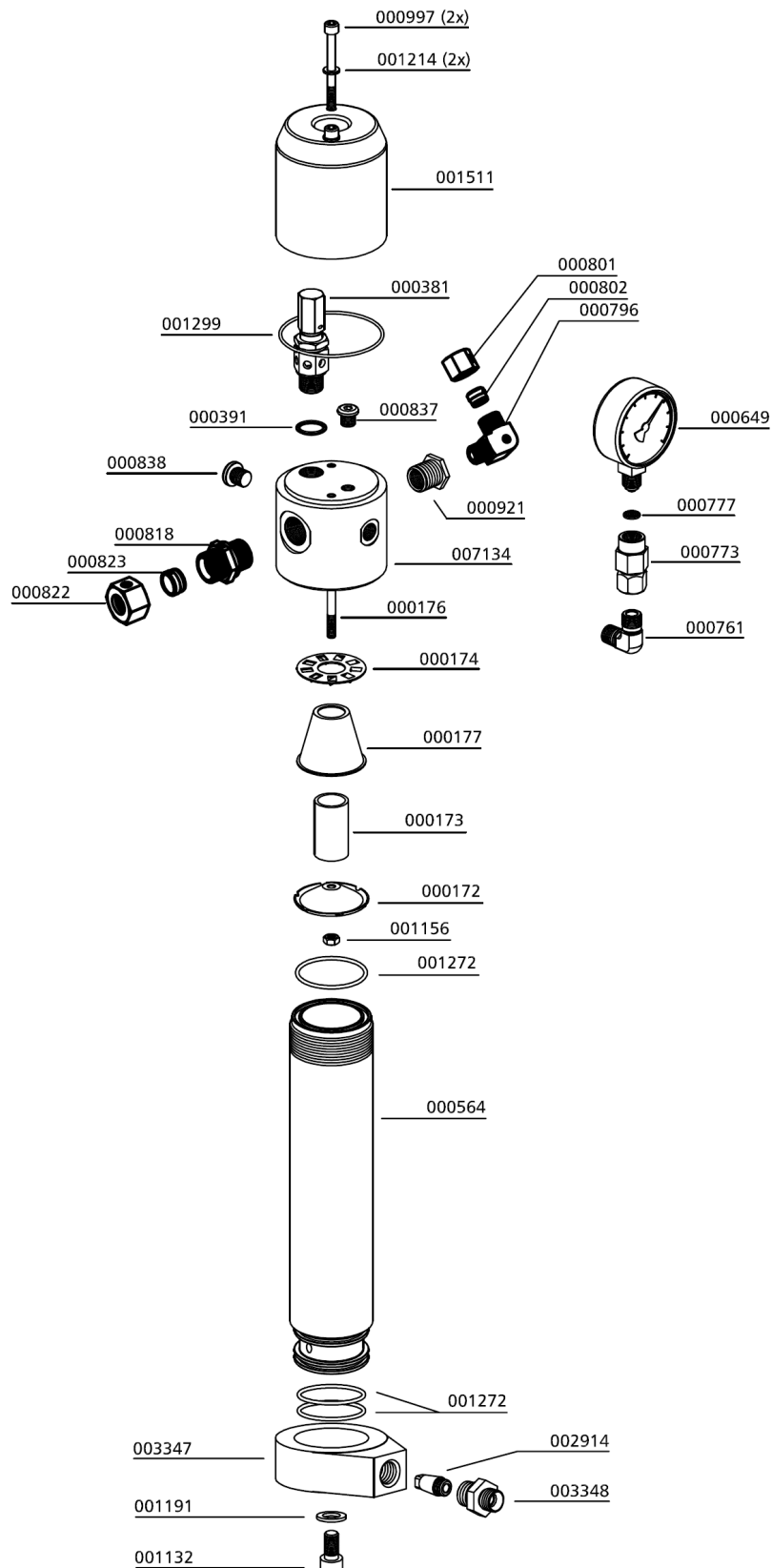

C



ERSATZTEILLISTE / SPARE PART LIST

Ölabscheider / Oil Separator

Best.-Nr. / Order No.	Benennung	Description
000175	Deckel, Wasserabscheider	Cap, Water separator
000183	Wasserabweiser	Filter Protecor
000184	Sinterfilter Wasserabscheider	Siltered Filter, Oil Filter
000185	Halteteller	Plate
000186	Drallscheibe	Twist Disk
000187	Stiftschraube	Threaded Stud
000497	Mutter M6	Nut M6
000498	Unterlegscheibe	Washer A6
000765	Schneidring, PSR 08 LX	Olive Seal, PSR 08 LX
000766	Mutter 8L	Nut 8L
000788	Verschraubung	Connection
000794	T-Verschraubung, EV10LOMDCF	Connection with fixed nut, EV10LOMDCF
000801	Mutter M10LCFX	Union Nut M10LCFX
000802	Schneidring 10mm PSR10LX	Olive Seal Ring PSR10LX
000859	Reduzierung mit fester Mutter RED10/08LOMDCF	Reducer with fixed nut, RED10/08LOMDCF
000861	Schneidring, PSR 18LX	Olive Seal, PSR 18LX
000862	Mutter, M18LCFX	Union Nut 18L, M18LCFX
000866	Verschraubung, GE18LRCFX	Connection, GE18LRCFX
001027	Zylinderschraube M6x30	Allen Bolt M6x30
001156	Stopfmutter M6 DIN985 ZN	Lock Nut M6
001294	O-Ring 68x3 NBR90	O-Ring 68x3
001431	Befestigungsring Wasserabscheider	Lock Ring Water Separator
002563	Wasserabscheider Oberteil PN 15 bar	Water Separator, upper comp. PN15 bar
002656	Halter Oelabscheider, Blechhalter	Holder oil separator
003708	Behälter Oelabscheider PN 15, G 1/4" IG	Container Oil Separ. PN 15 bar, G 1/4" IG

DETAILANSICHT / DETAILED VIEW

Ölabscheider / Oil Separator

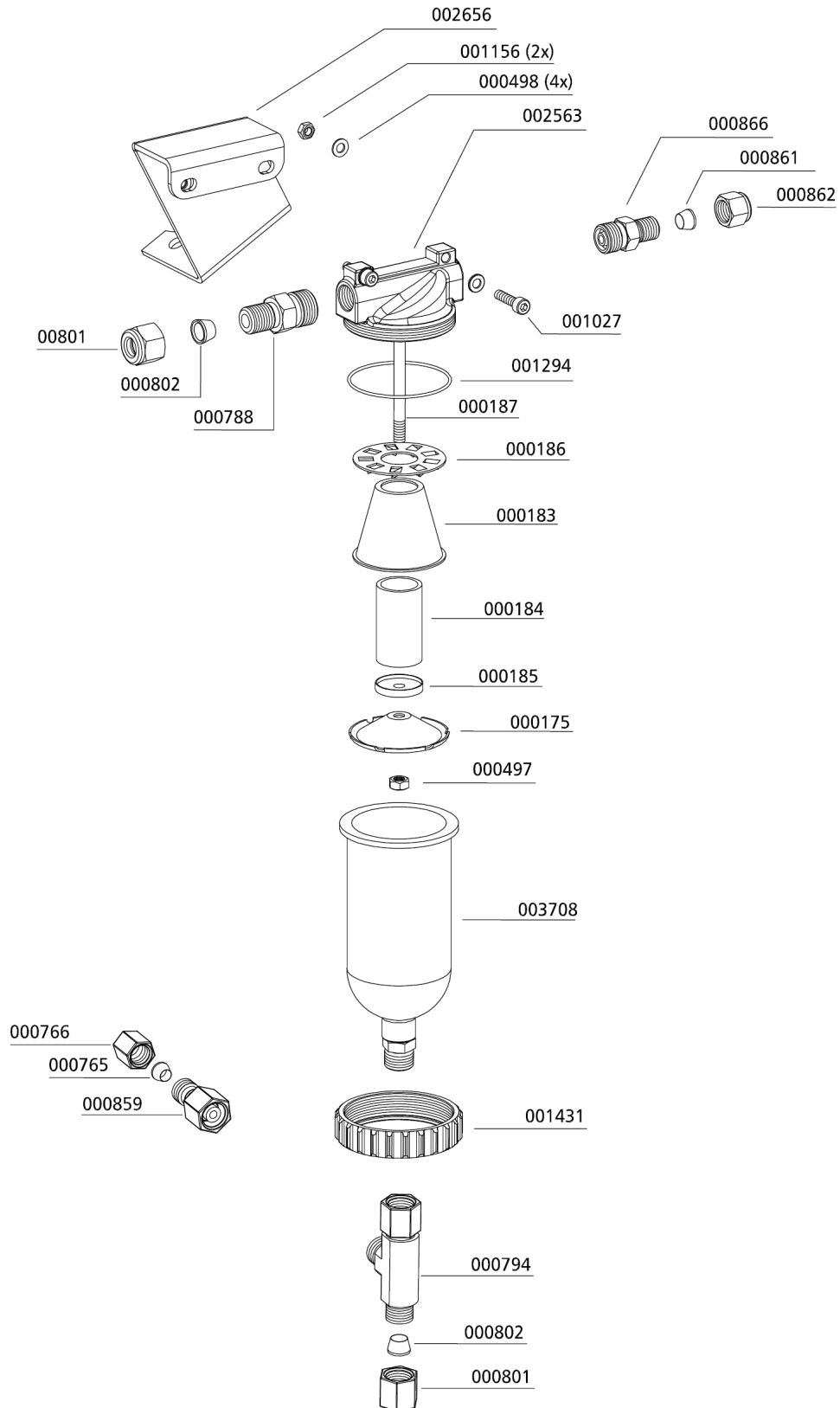

C

Ölverteilerblock / Oil Manifold Block

Best.-Nr. / Order No.	Benennung	Description
000645	Manometer, glyzeringefüllt, 0-10 bar Ø 63mm	Pressure Gauge, glycerine, 0-10 bar Ø 63mm
000710	Verschraubung GE06LRFCX	Connection GE06LRFCX
000722	Verschraubung WE06SRFCX	Connection WE06SRFCX
000732	Mutter M06LCFX	Union M06LCFX
000733	Schneidring PSR06FX	Olive Seal PSR06FX
000738	Verschraubung GE08LRFCX	Connection GE08LRFCX
000773	Verschraubung	Connection Pressure Gauge
000761	Verschraubung, WE08LRFCX	Elbow Connection, WE08LRFCX
000765	Schneidring, PSR 08 LX	Olive Seal, PSR 08 LX
000766	Mutter, M08LCFX	Nut, M08LCFX
000777	Dichtring für Manometerverschraubung DK11/4CFX	Seal Ring for Pressure Gauge DK11/4CFX
000838	Verschlussstopfen, VSTIR1/4EDCF	Plug, VSTIR1/4EDCF
000895	Doppelnippel, G1/2" FF33MS	Double Nipple, G1/2" FF33MS
000921	Reduzierung RI1/2X1/4CFX	Reducer RI1/2X1/4CFX
001058	Zylinderschraube M8x70mm DIN912 8.8 ZN	Allen Bolt M8x70mm DIN912 8.8 ZN
003928	Ölfilterpatrone	Oil filter cartridge
003929	Ölfilterflansch, Alu	Oil filter flange, alloy
003934	Ölverteilerblock, Alu	Oil manifold block, alloy
007962	Öldruckleitung Verteiler - Stufe 3	Oil pressure pipe
007963	Öldruckleitung Verteiler - Stufe 4	Oil pressure pipe
007964	Öldruckleitung Verteiler - Ölpumpenfl.	Oil pressure pipe

DETAILANSICHT / DETAILED VIEW

Ölverteilerblock / Oil Manifold Block

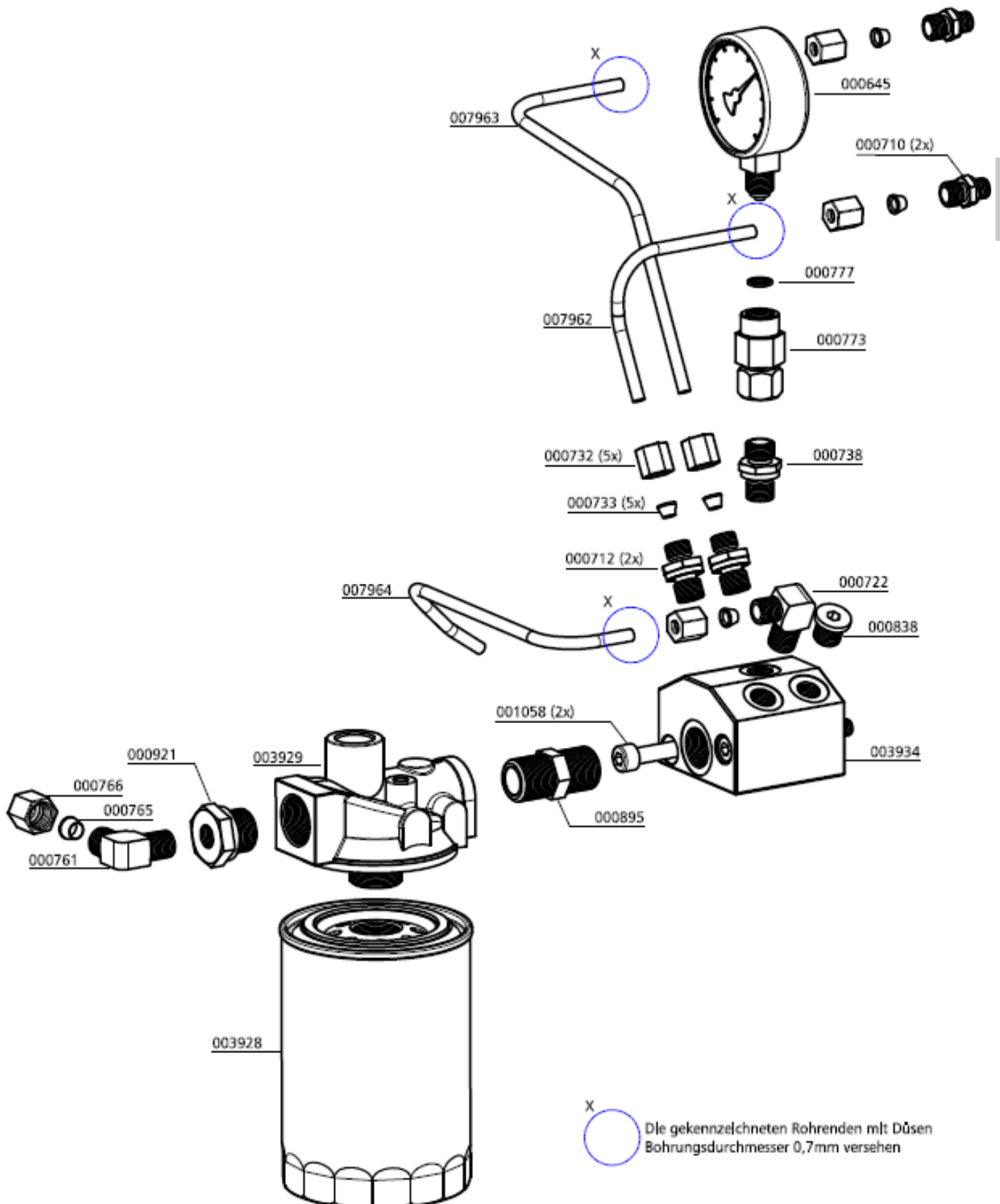

C



ERSATZTEILLISTE / SPARE PART LIST

Baugruppe: Filter 0,8l / Assembly: Filter 0.8ltr

Best.-Nr. / Order No.	Benennung	Description
000652	Manometer, glyzeringefüllt Edelstahl, 0-400 bar / PSI Ø 63mm	Press. Gauge, glycerin, s/s, 0-400 bar / PSI Ø 63mm
000761	Verschraubung WE08LRCFX	Elbow Connection WE08LRCFX
000765	Schneidring, PSR 08 LX	Olive Seal, PSR 08 LX
000766	Mutter, M08LCFX	Nut, M08LCFX
000773	Verschraubung, IG 1/4" MAVE 08 LR (c/w fixed nut)	Connection Pressure Gauge, IG 1/4" MAVE 08 LR (c/w fixed nut)
000777	Dichtring für Manometerverschraubung, DK11/4CFX	Seal Ring for Pressure Gauge, DK11/4CFX
000921	Reduzierung RI1/2X1/4CFX	Reducer RI1/2X1/4CFX
001040	Zylinderschraube, M8x20mm DIN912 8.8 ZN	Allen Bolt, M8x20mm DIN912 8.8 ZN
001158	Mutter M8 DIN934 ZN	Nut M8 DIN934 ZN
001181	U-Scheibe A8 DIN125 ZN	Washer A8 DIN125 ZN
001244	O-Ring, 16x2 NBR70	O-Ring, 16x2 NBR70
001598	Sicherheitsventil Erdgas - 305 bar	Safety Valve CNG - 305 bar
002658	Sicherheitsventil Erdgas - 330 bar	Safety Valve CNG - 330 bar
003980	Partikelfilterpatrone	Particle filter cartridge
003994	Filterbehälter 350 bar, 0,8 l, komplett	Filter case 350 bar, 0.8ltr, complete
003997	Filterstütze Partikelfilter 0,8 l	Filter support 0,8 ltr
004221	O-Ring, 54,2 x 3,0 FKM80	O-Ring, 54,2 x 3,0 FKM80
004222	Stützring, 55,4x60x1,4	Back-up Ring, 55,4x60x1,4
004795	Sicherheitsventil Erdgas - 275 bar	Safety Valve CNG - 275 bar
005209	Sicherheitsventil Erdgas - 315 bar	Safety Valve CNG - 315 bar
005233	Adapter Stecksockel auf G1/2" IG	Adapter plug base to 1/2" female
005599	Sicherheitsventil Erdgas - 320 bar	Safety Valve CNG - 320 bar
006017	Sicherheitsventil Erdgas - 270 bar	Safety Valve CNG - 270 bar
006363	Haltebügel Filtergehäuse 0,8 l	U-Clamp Filterhousing 0.8 ltr
006364	Halteschalen Filtergehäuse 0,8 l	Bracket Filter Housing 0.8 ltr
006892	Sicherheitsventil Erdgas - 275 bar (ohne TÜV)	Safety Valve CNG - 275 bar (w/o TÜV)
008141	Sicherheitsventil G1/2" Erdgas - 15 bar	Safety Valve CNG - 15 bar

DETAILANSICHT / DETAILED VIEW

Baugruppe: Filter 0,8l / Assembly: Filter 0.8ltr

- 008141 (25 bar, mit / c/w TÜV)
- 006017 (270 bar, mit / c/w TÜV)
- 006892 (275 bar, ohne / w/o TÜV)
- 004795 (275 bar, mit / c/w TÜV)
- 001598 (305 bar, mit / c/w TÜV)
- 005209 (315 bar, mit / c/w TÜV)
- 005599 (320 bar, mit / c/w TÜV)
- 002658 (330 bar, mit / c/w TÜV)

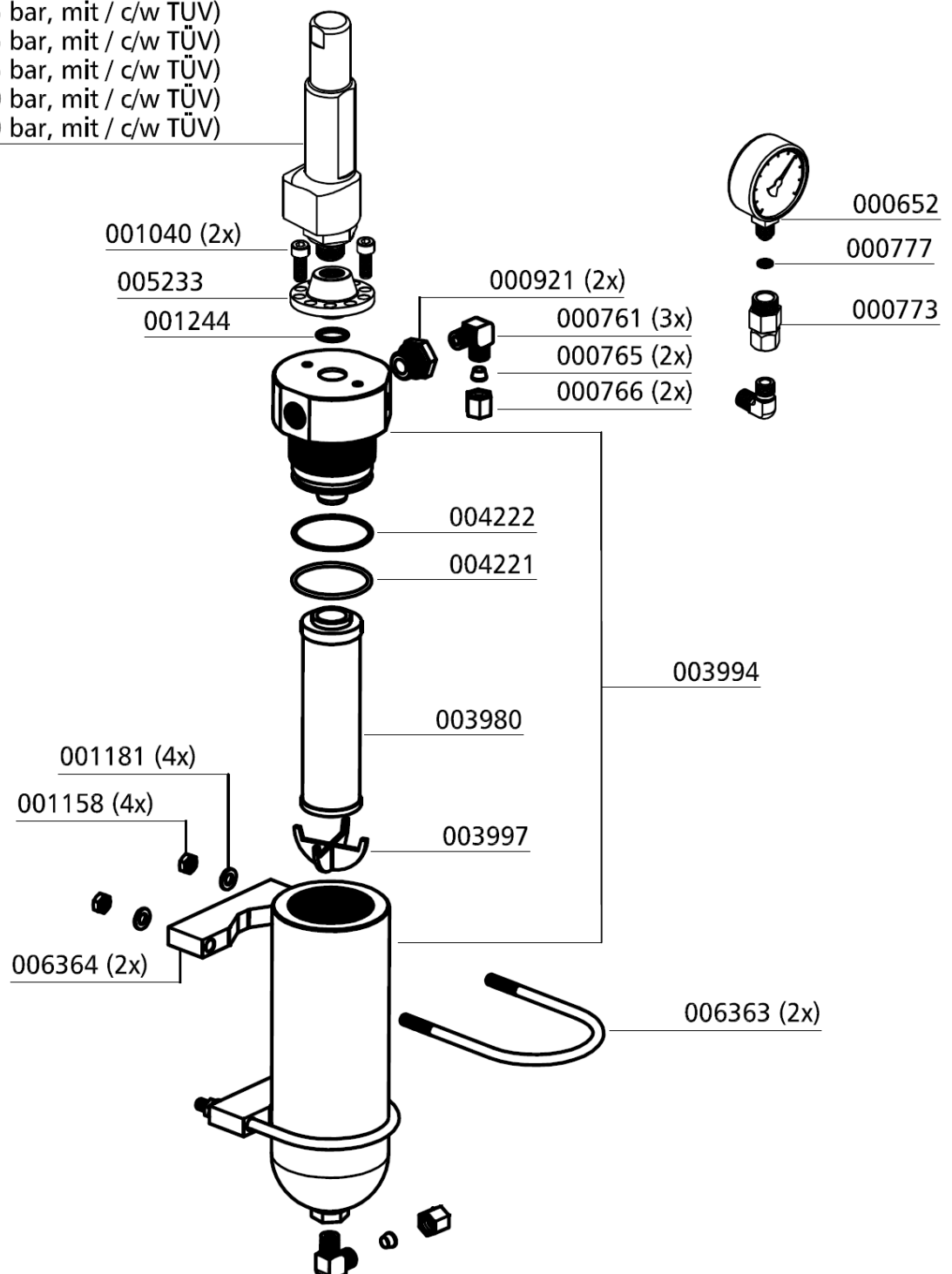



ERSATZTEILLISTE / SPARE PART LIST

Magnetventil 1. Stufe / Solenoid Valve 1st Stage

Best.-Nr. / Order No.	Benennung	Description
000599	Klemmmutter, Magnetventil	Lock Nut, Solenoid
000607	Magnetspule NC 230V AC 40 bar TM30, ohne Stecker	Solenoid Coil NC 230V AC 40bar, w/o plug
000761	Verschraubung, WE08LRCFX	Elbow Connection, WE08LRCFX
000765	Schneidring, PSR 08 LX	Olive Seal, PSR 08 LX
000766	Mutter, M08LCFX	Nut, M08LCFX
000797	Verschraubung mit fester Mutter, EW10LCFX	Elbow Connection c/w fixed nut, EW10LCFX
000799	Verschraubung mit fester Mutter, EVGE 10L R ED	Connection with fixed nut, EVGE 10L R ED
001546	Aludichtring für Magnetventile, 18 x 13,2 x 2,5mm	Alloy Seal Ring for solenoid, 18 x 13,2 x 2,5mm
003573	Wellenscheibe, Magnetventil	Shaft washer, solenoid valve
004002	Magnetventil	Solenoid Valve

C

DETAILANSICHT / DETAILED VIEW

Magnetventil 1. Stufe / Solenoid Valve 1st Stage

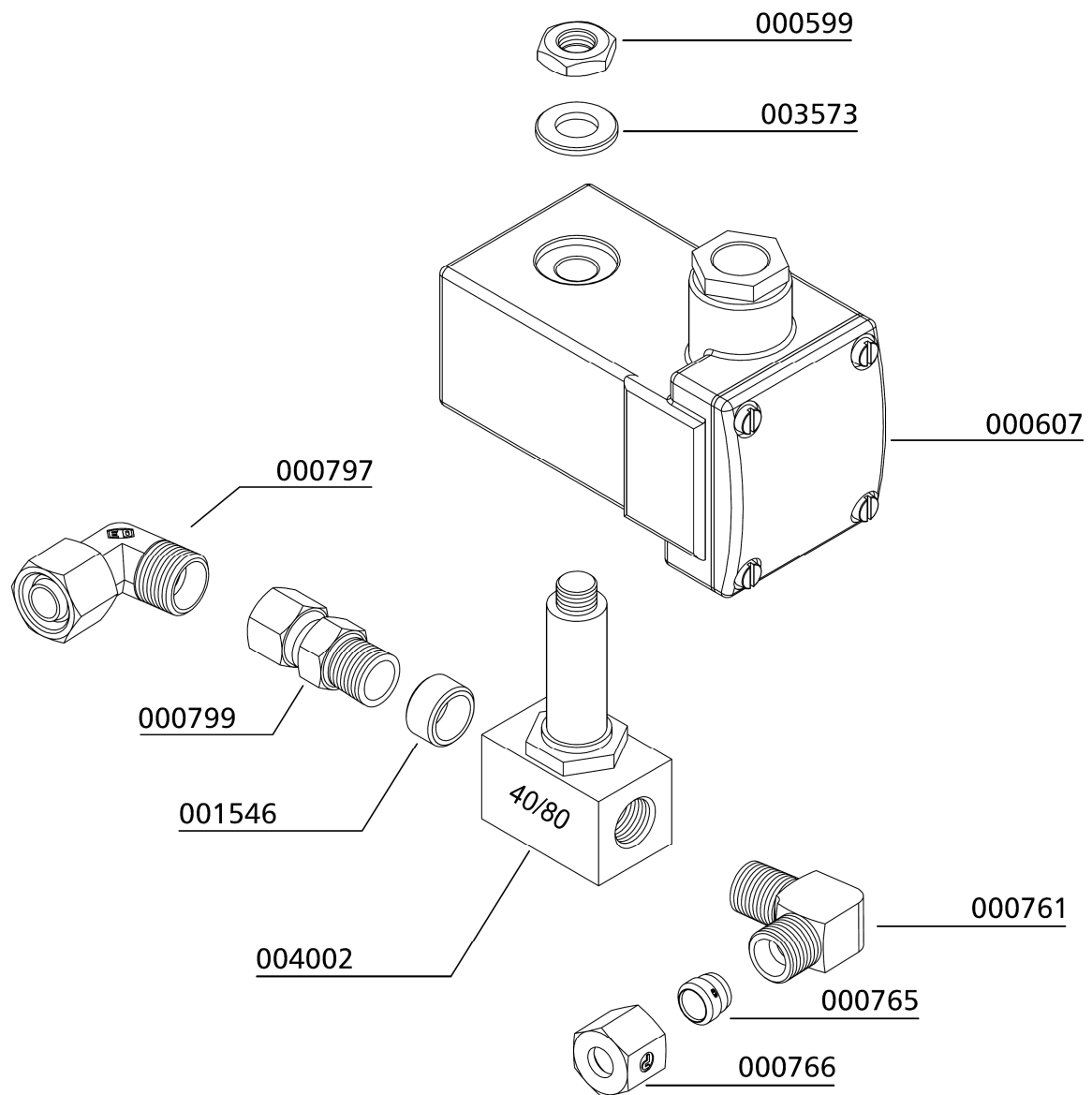

C



ERSATZTEILLISTE / SPARE PART LIST

Magnetventil 2. Stufe / Solenoid Valve 2nd Stage

Best.-Nr. / Order No.	Benennung	Description
000599	Klemmmutter, Magnetventil	Lock Nut, Solenoid
000607	Magnetspule NC 230V AC 40 bar TM30, ohne Stecker	Solenoid Coil NC 230V AC 40bar, w/o plug
000722	Verschraubung, WE06SRCFX	Connection, WE06SRCFX
000733	Schneidring, PSR06FX	Olive Seal, PSR06FX
000734	Mutter, M06SCFX	Nut, M06SCFX
000799	Verschraubung mit fester Mutter, EVGE 10L R ED	Connection with fixed nut, EVGE 10L R ED
001546	Aludichtring für Magnetventile, 18 x 13,2 x 2,5mm	Alloy Seal Ring for solenoid, 18 x 13,2 x 2,5mm
003573	Wellenscheibe, Magnetventil	Shaft washer, solenoid valve
004002	Magnetventil	Solenoid Valve

C

DETAILANSICHT / DETAILED VIEW

Magnetventil 2. Stufe / Solenoid Valve 2nd Stage

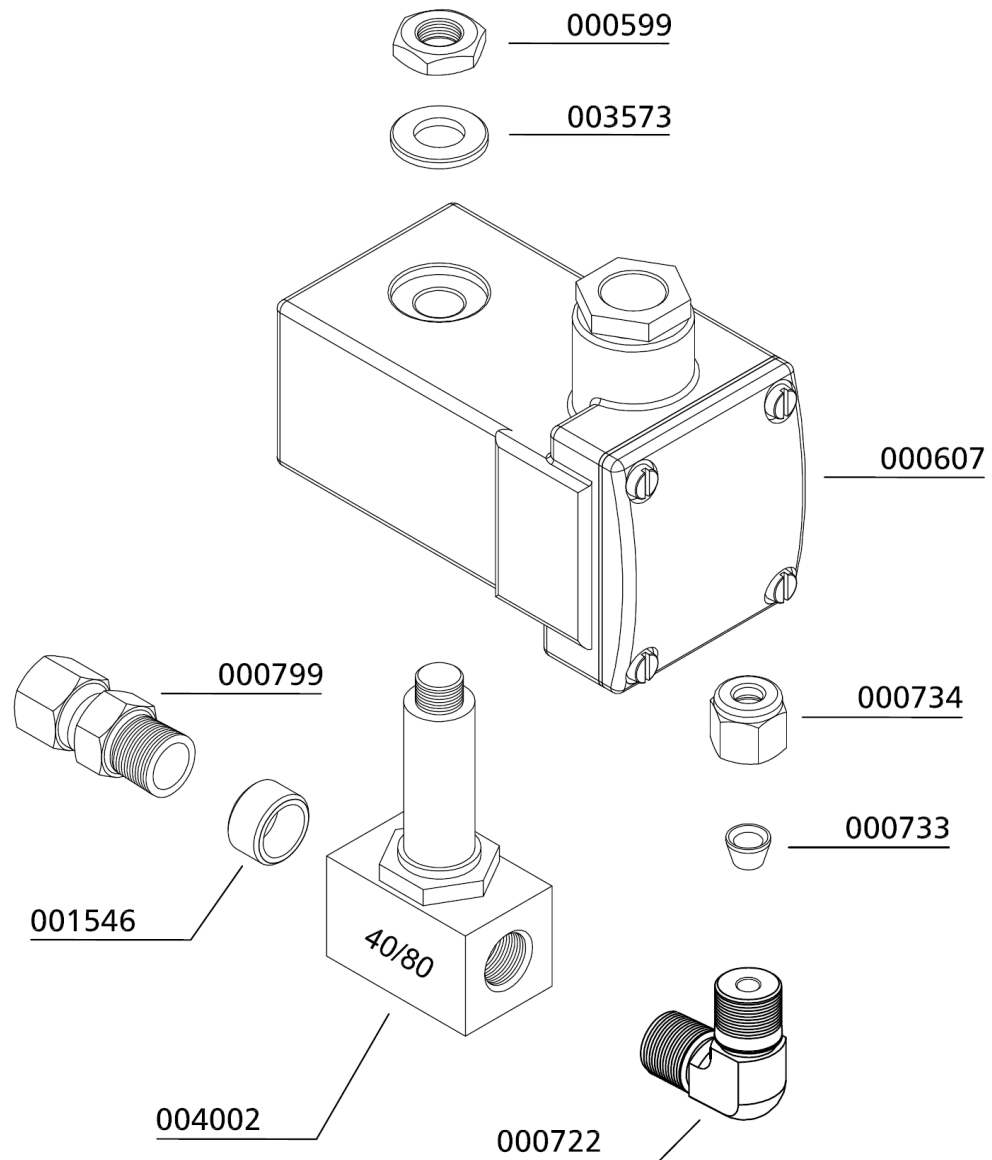

C



ERSATZTEILLISTE / SPARE PART LIST

Magnetventil 3. & 4. Stufe / Solenoid Valve 3rd & 4th Stage

Best.-Nr. / Order No.	Benennung	Description
000599	Klemmmutter, Magnetventil	Lock Nut, Solenoid
000606	Magnetspule NC 230V AC 80 bar	Solenoid Coil NC 230V AC 80 bar
000712	Verschraubung, GE06LR1/4CFX	Connection, GE06LR1/4CFX
000732	Mutter, M06LCFX	Union Nut, M06LCFX
000733	Schneidring, PSR06FX	Olive Seal, PSR06FX
000799	Verschraubung mit fester Mutter, EVGE 10L R ED	Connection with fixed nut, EVGE 10L R ED
001546	Aludichtring für Magnetventile, 18 x 13,2 x 2,5mm	Alloy Seal Ring for solenoid, 18 x 13,2 x 2,5mm
003573	Wellenscheibe, Magnetventil	Shaft washer, solenoid valve
004002	Magnetventil 40/80 bar, NC 2x 1/4", Gehäuse: Messing, ohne Spule	Solenoid Valve 40/80 bar, NC 1.2 G1/4" , housing: brass, w/o coil

C

DETAILANSICHT / DETAILED VIEW

Magnetventil 3. & 4. Stufe / Solenoid Valve 3rd & 4th Stage

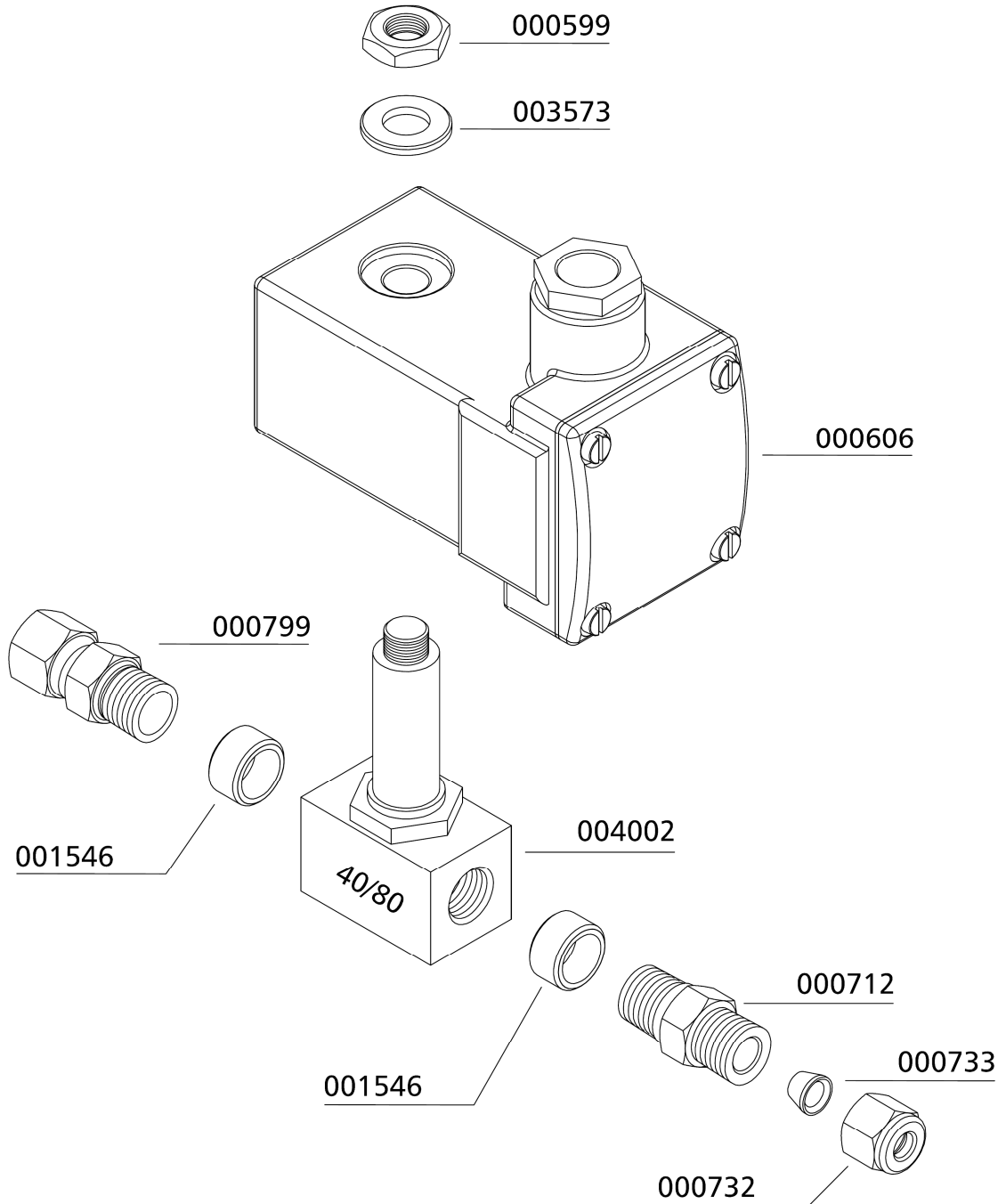

C



ERSATZTEILLISTE / SPARE PART LIST

Pneum. Kondensat-Ablassventil / Pneumatic Condensate Valve

Best.-Nr. / Order No.	Benennung	Description
000188	Sinterfilter	Sintered Filter
000189	Steuerkolben, pneum. Kondensatventil	Piston, Condensation Valve
000190	O-Ring Pneumatisches Kondensatventil, 10 x 2,5 NBR90	O-Ring, Condensate Valve, 10 x 2,5 NBR90
000192	O-Ring, pneum. Kondensatventil, 13 x 2,5 NBR 90	O-Ring, Pilot Valve, 13 x 2,5 NBR 90
000195	Düsenschraube, pneum. Kondensatventil	Inlet Jet Screw
000197	Stopfen, pneum. Kondensatventil	Plug
000198	Gehäuse, pneum. Kondensatventil	Body PCV
000498	U-Scheibe DIN 125 A6	Washer DIN 125 A6
000732	Mutter, M06LCFX	Union, M06LCFX
000733	Schneidring, PSR06FX	Olive Seal, PSR06FX
000738	Verschraubung GE08LRFCX	Connection GE08LRFCX
000913	A-Lok Verschraubung, M8MSEL 1/4K-316	A-Lok Connection, M8MSEL 1/4K-316
001026	Zylinderschraube, M6x40mm DIN912	Allen Bolt, M6x40mm DIN912 8.8 ZN

DETAILANSICHT / DETAILED VIEW

Pneum. Kondensat-Ablassventil / Pneumatic Condensate Valve

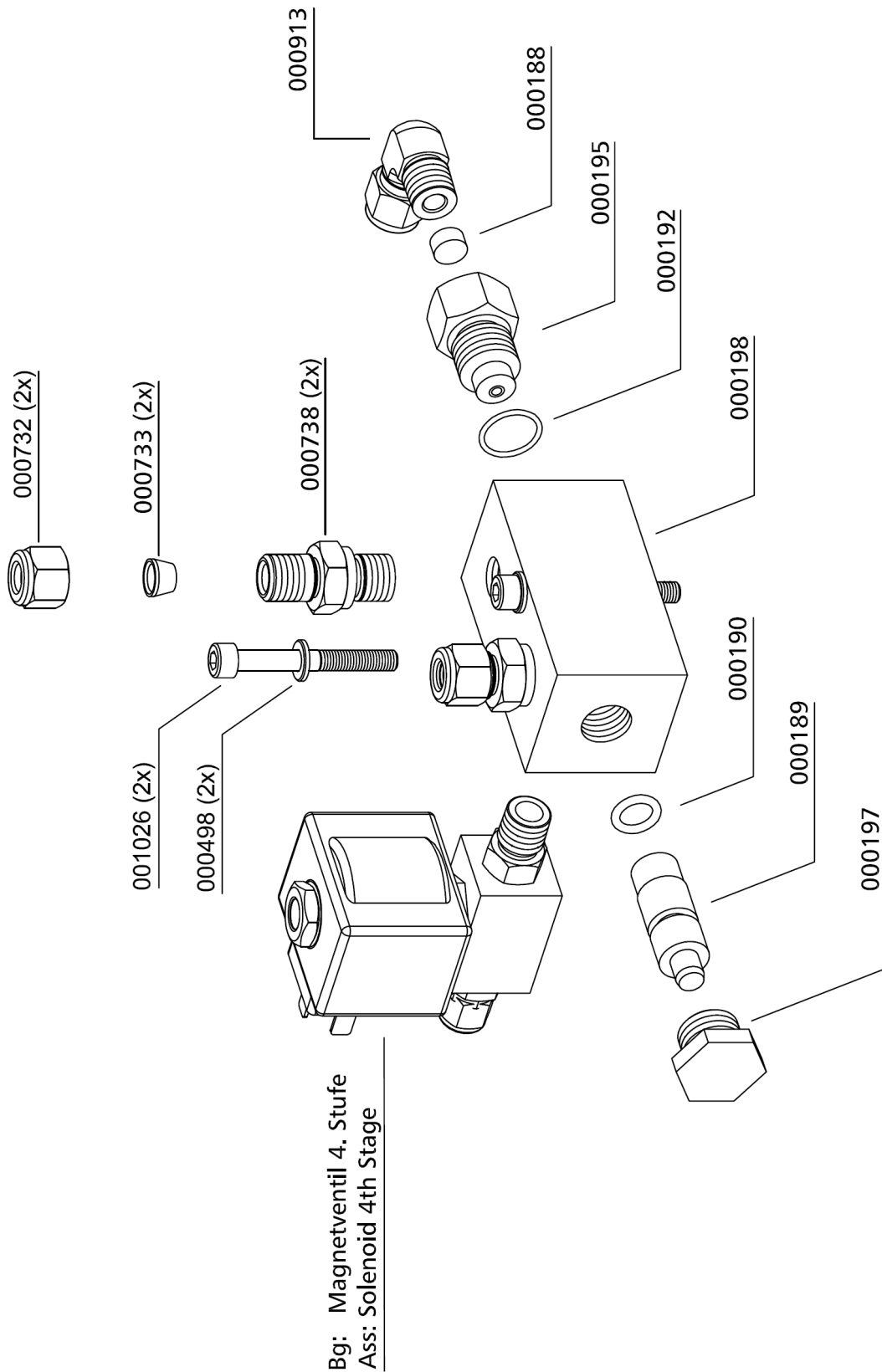



ERSATZTEILLISTE / SPARE PART LIST

Kondensatablaseinheit / Condensate Drain Unit

Best.-Nr. / Order No.	Benennung	Description
000592	Verschraubung, GE06LR1/4CFX	Connection, GE06LR1/4CFX
000712	Kugelhahnventil DN6, 2 x G1/4" IG PN 500 bar	Lever Ball Valve DN6, 2 x G1/4" IG PN 500 bar
000738	Verschraubung, GE08LRFCX	Connection, GE08LRFCX
000765	Schneidring, PSR 08 LX	Olive Seal, PSR 08 LX
000766	Mutter, M08LCFX	Union Nut, M08LCFX
000783	Verschraubung, GE10L - R1/4"	Straight Connection, GE10L - R1/4"
000784	Verschraubung, GE10SR1/4CFX	Connection, GE10SR1/4CFX
000799	Verschraubung mit fester Mutter, EVGE 10L R ED	Connection with fixed nut, EVGE 10L R ED
000801	Mutter, M10LCFX	Union Nut, M10LCFX
000802	Schneidring, PSR10LX	Olive Seal Ring, PSR10LX
001043	Zylinderschraube, M8x35mm DIN912 8.8 ZN	Allen Screw, M8x35mm DIN912 8.8 ZN
001181	U-Scheibe, A8 DIN125 ZN	Washer, A8 DIN125 ZN
002628	Schlauch, rot, Atex geprüft, Erdgas	Hose, red, Atex prooved, CNG
002660	Kondensatableiste, 8x G1/4"	Condensate Bar, 8x G1/4"

C

DETAILANSICHT / DETAILED VIEW

Kondensatablasseinheit / Condensate Drain Unit

C

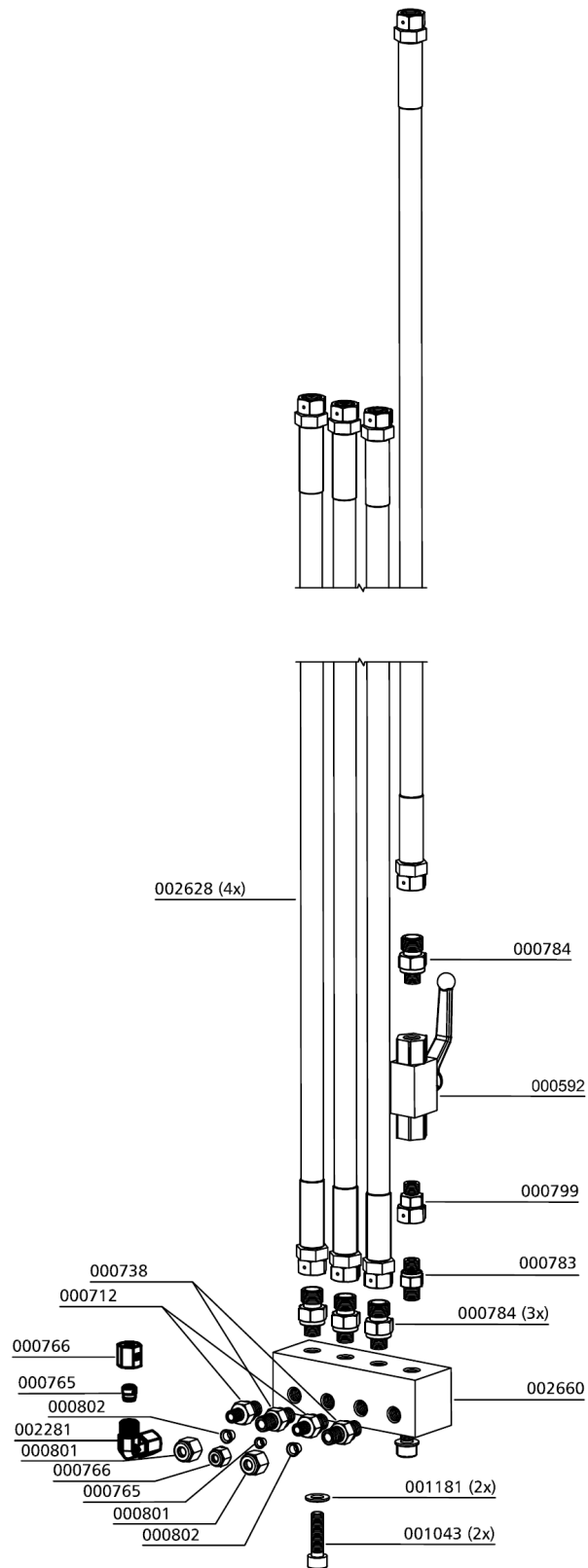



ERSATZTEILLISTE / SPARE PART LIST

Kühler 1. Stufe / Cooler 1st Stage

Best.-Nr. / Order No.	Benennung	Description
000876	Verschraubung, GE28L/1"R CFX	Connection, GE28L/1"R CFX
000877	Verschraubung, EVW28LOMDCF	Connection, EVW28LOMDCF
000880	Überwurfmutter, M28LCFX	Union Nut, M28LCFX
000881	Schneidring, PSR28LX	Oliver Seal, PSR28LX
001163	Mutter, M10 DIN934 ZN	Nut, M10 DIN934 ZN
001164	Stopfmutter, M10 DIN985 ZN	Allen Screw, M10 DIN985 ZN
001186	U-Scheibe, A10 DIN125 ZN	Washer, A10 DIN125 ZN
001675	Gummilager	Rubber Mounts
002629	Kühler 1. Stufe	Cooler 1st stage

C

DETAILANSICHT / DETAILED VIEW

Kühler 1. Stufe / Cooler 1st Stage

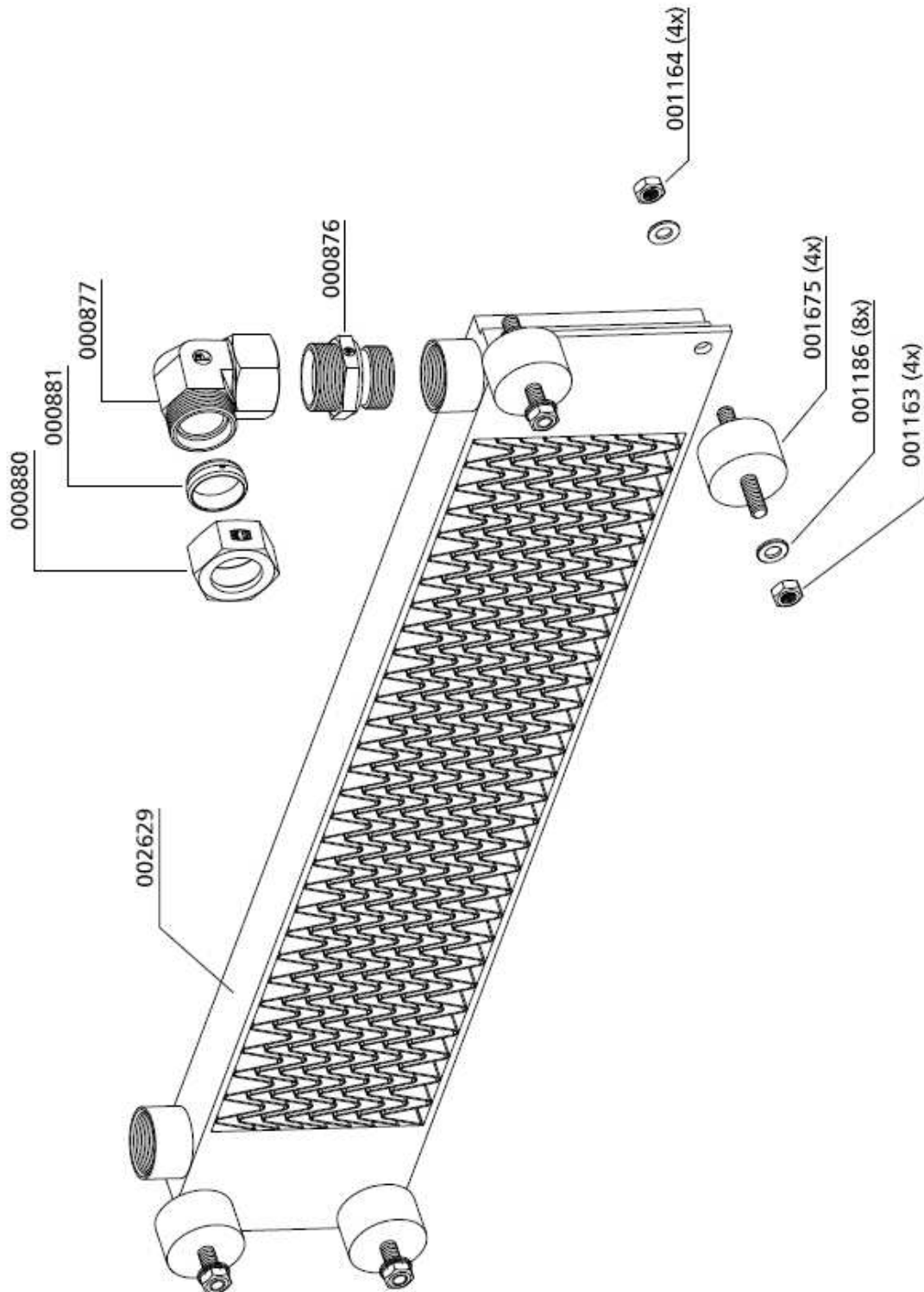

C



ERSATZTEILLISTE / SPARE PART LIST

Kühler 2. Stufe / Cooler 2nd Stage

Best.-Nr. / Order No.	Benennung	Description
000876	Verschraubung, GE28L/1"R CFX	Connection, GE28L/1"R CFX
000877	Verschraubung, EVW28LOMDCF	Connection, EVW28LOMDCF
000880	Überwurfmutter, M28LCFX	Union Nut, M28LCFX
000881	Schneidring, PSR28LX	Oliver Seal, PSR28LX
000966	Zylinderschraube, M10x25mm DIN912 8.8 ZN	Allen Bolt, M10x25mm DIN912 8.8 ZN
001122	Senkkopfschraube, M10x16mm DIN7991 8.8 ZN	Counter Sunk Screw, M10x16mm DIN7991 8.8 ZN
001186	U-Scheibe, A10 DIN125 ZN	Washer, A10 DIN125 ZN
002630	Kühler 2. Stufe	Cooler 2nd stage

C

DETAILANSICHT / DETAILED VIEW

Kühler 2. Stufe / Cooler 2nd Stage

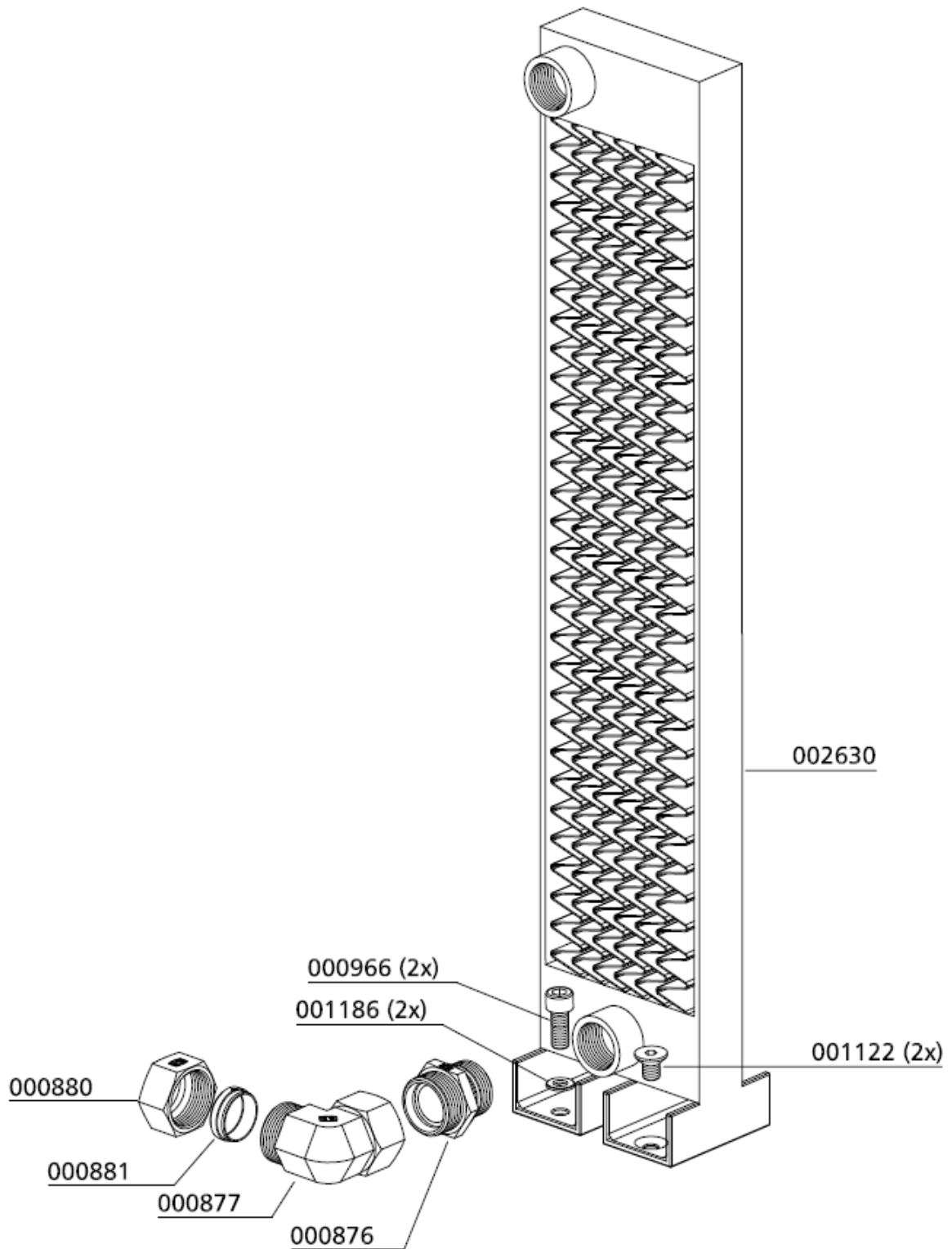

C



ERSATZTEILLISTE / SPARE PART LIST

Kühler 3. Stufe / Cooler 3rd Stage

Best.-Nr. / Order No.	Benennung	Description
000818	Verschraubung, GE15LRFCX	Connection, GE15LRFCX
000820	Verschraubung, WE15LRFCX	Connection, WE15LRFCX
000969	Zylinderschraube, M10x40mm DIN912 8.8 ZN	Allen Bolt, M10x40mm DIN912 8.8 ZN
001040	Zylinderschraube, M8x20mm DIN912 8.8 ZN	Allen Screw, M8x20mm DIN912 8.8 ZN
001164	Stopfmutter, M10 DIN985 ZN	Lock Nut, M10 DIN985 ZN
001181	U-Scheibe, A8 DIN125 ZN	Washer, A8 DIN125 ZN
001186	U-Scheibe, A10 DIN125 ZN	Washer, A10 DIN125 ZN
002631	Rahmen, Kühler 3. Stufe	Frame Cooler, 3rd stage
002632	Haltebügel, Kühler 3. Stufe	Holder, Cooler 3rd stage
002633	Kühlrohreinheit 3. Stufe	Cooling pipes 3rd stage

C

DETAILANSICHT / DETAILED VIEW

Kühler 3. Stufe / Cooler 3rd Stage

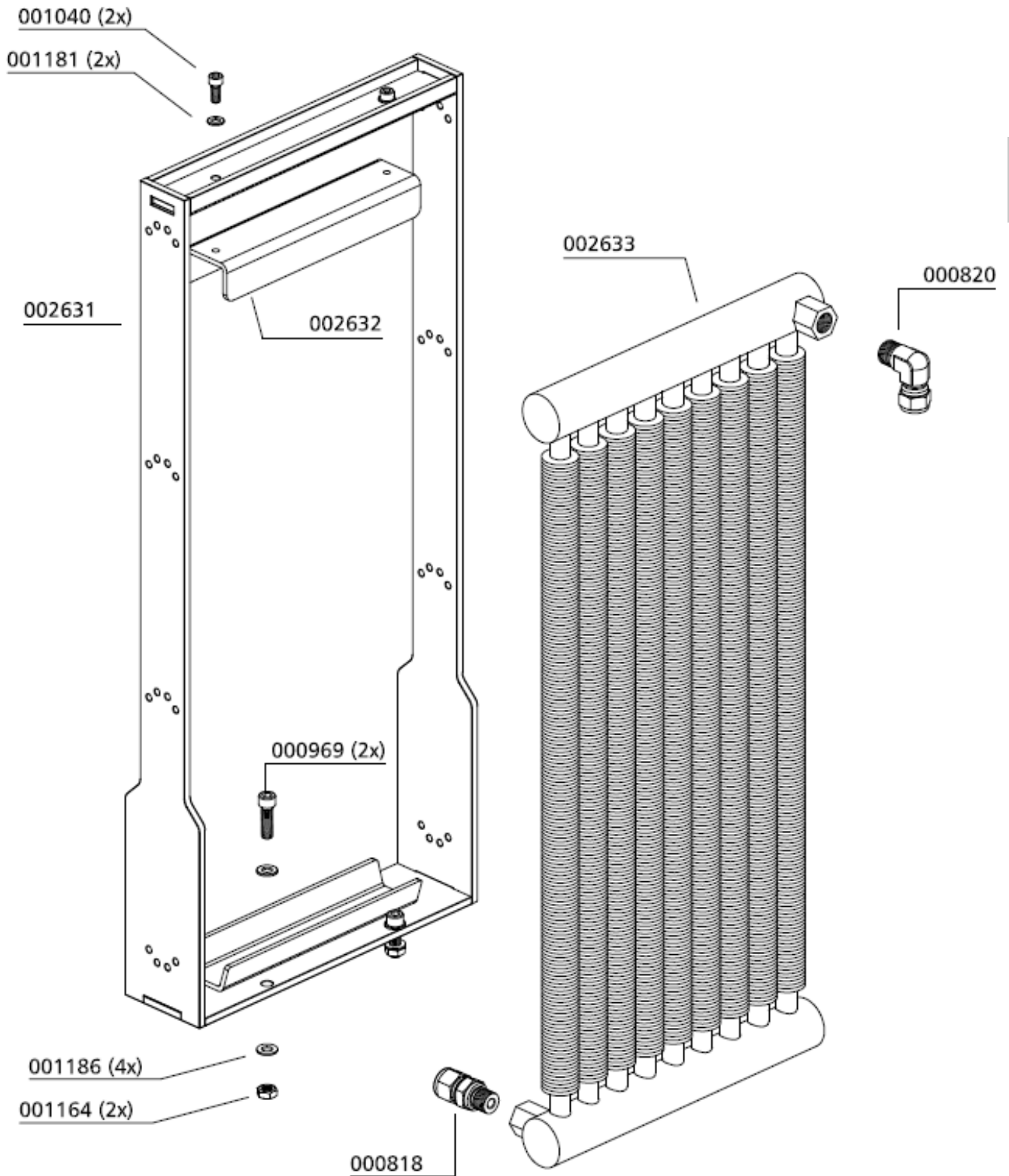

C



ERSATZTEILLISTE / SPARE PART LIST

Kühler 4. Stufe / Cooler 4th Stage

Best.-Nr. / Order No.	Benennung	Description
000498	U-Scheibe, DIN 125 A6	Washer, DIN 125 A6
000638	Doppelschelle, 2 x 8 mm - 1 Paar	Pipe Clamp, 2 x 8 mm - 1 pair
000735	Verschraubung, G08LCFX	Connection, G08LCFX
000765	Schneidring, PSR 08 LX	Olive Seal, PSR 08 LX
000766	Mutter, M08LCFX	Nut, M08LCFX
001027	Zylinderschraube, M6x30mm DIN912 8.8 ZN	Allen Bolt, M6x30mm DIN912 8.8 ZN
001030	Zylinderschraube, M6x16mm DIN912 8.8 ZN	Allen Bolt, M6x16mm DIN912 8.8 ZN
002634	Halterahmen Kühler 4. Stufe	Frame Cooler 4th stage
002635	Haltewinkel 3. Stufe	Bracket support 3rd stage
002636	Haltewinkel 4. Stufe	Bracket support 4th stage
006543	Blindnietmutter	Blind rivet nut

C

DETAILANSICHT / DETAILED VIEW

Kühler 4. Stufe / Cooler 4th Stage

Kühlereinheit kompl.: 004794
 ohne:
 - 000498
 - 000735
 - 000765
 - 000766
 - 001030
 - 002635
 - 002636

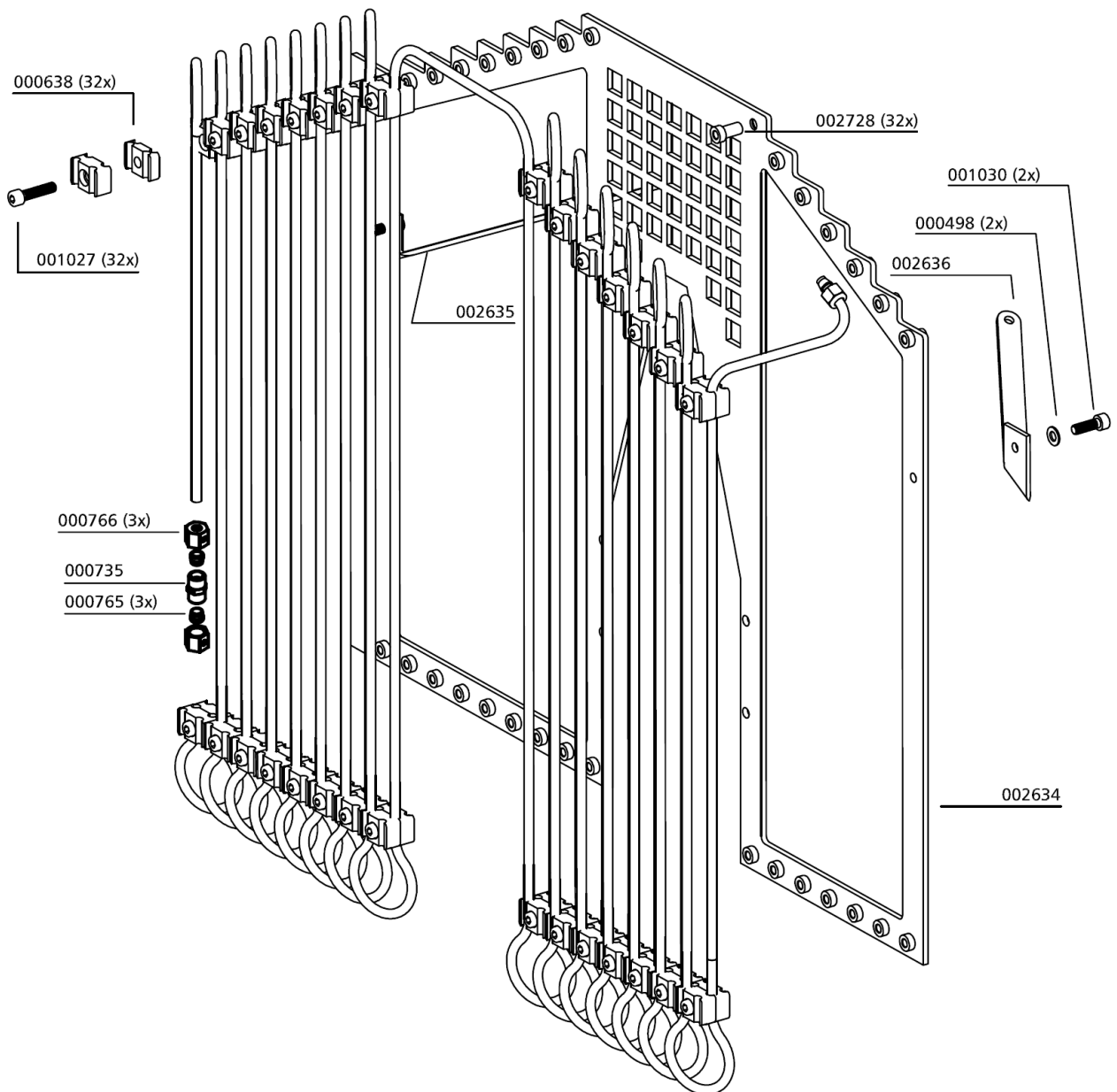

C



OPTIONS



Table of Contents

Special Voltage.....	2
Auto Start Function.....	5
Oil Temperature Monitoring	10
Cylinder Head Temperature Monitoring	13
Special Machine Feets	16
420bar Version	18
Condensate Tank 60L	28



SPECIAL VOLTAGE

D



SPECIAL VOLTAGE

Special Voltage

The compressor unit can be equipped with different voltages and frequencies. The power of the compressor motor can be lower and higher based on the needed requirement.

The following table will show possible voltages and frequencies. The associated data sheets can be found in the following pages.



Note

If your required data sheet is missing, please contact us directly under service@lw-compressors.com.

D

Possible special voltages and frequencies

Voltage	Frequency
440 V	50 Hz
440 V	60 Hz
230 V	50 Hz
230 V	60 Hz

SPECIAL VOLTAGE

Technical Data

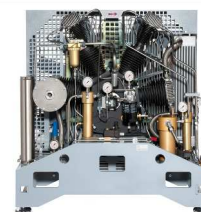

Technical Data	LW 1300 E
Capacity [l/min]:	1300
Max. Operating Pressure [bar]:	350 (optional 420)
RPM [min ⁻¹]:	985
Number of Pressure Stages:	4
Cylinder Bore 1st Stage [mm]:	Ø 135
Cylinder Bore 2nd Stage [mm]:	Ø 70
Cylinder Bore 3rd Stage [mm]:	Ø 32
Cylinder Bore 4th Stage [mm]:	Ø 16
Medium:	Compressed Air / Breathing Air
Intake Pressure:	atmospheric
Oil Pressure [bar]:	+3 (+- 0.5)
Oil Capacity [l]:	5.0
Intake Temperature [°C]:	0 < +45
Ambient Temperature [°C]:	+5 < +45
Cooling Air Volume [m ³ /h]:	> 13,320
Voltage:	440 V / 3 phase / 60 Hz
Protection Class Drive Motor:	IP 55
Drive Power [kW]:	44,4
Power Consumption [kW]:	39,5
RPM Motor [min ⁻¹]:	2,890
Start:	Star/Delta
Noise level [dB(A)]:	89 from a distance of 1 m
Dimensions L x W x H [mm]:	1,620 x 1,210 x 1,275
Weight [kg]:	approx. 1000
Content Volume Filter housing [l]:	3 x 2.3



AUTO START FUNCTION

D

AUTO START FUNCTION

Auto Start Function

The auto start function allows operating the compressor optionally in automatic or semi-automatic mode by turning the selector switch.

Semi-automatic operation:

Start the compressor by pushing the Start button. The compressor automatically shuts off when final pressure is reached. To restart the compressor, push the Start button again. The unit can be shut down at any time during operation by pushing the Stop button.



Selector switch auto start function

Automatic operation:

Start the compressor only once by pushing the Start button. The Start button lights up and the unit automatically shuts off when final pressure is reached. If outlet pressure decreases below the selected minimum pressure, the unit automatically restarts.



Note

The compressor can not be manually started during automatic operation.

To enable a manual start, shut off automatic operation by pushing the Stop button (Start button lamp goes out). Now turn selector switch to semi-automatic mode and start the compressor with the Start button.

Adjust re-start pressure (minimum filling pressure)

The pressure switch for start pressure is located after the pressure maintaining valve. The pressure can be adjusted with the upper adjusting screw.

Increasing re-start pressure: turn adjusting screw clockwise

Reducing re-start pressure: turn adjusting screw anti-clockwise

Adjust pressure switch in steps of a quarter turn. Check settings after every adjustment step.

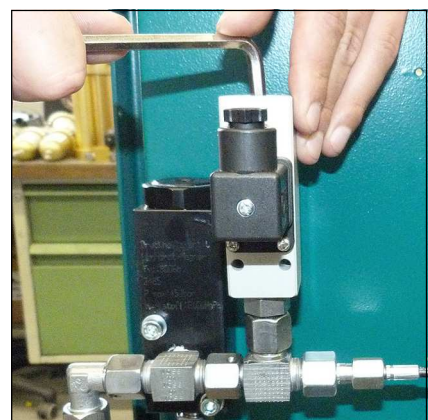

Adjust re-start pressure

AUTO START FUNCTION

Filling procedure semi-automatic operation



Caution! Only fill cylinders which:

- are marked with the test mark and the test stamp of the expert.
- have been hydro static tested (check last test date).
- are rated for the final pressure.
- are free from humidity.



Note

The unit shuts down when final pressure is reached. Thus, the unit always has to be restarted manually.

1. Turn selector switch to semi-automatic mode.
2. Close all filling valves.
3. Connect closed compressed air cylinders.
4. Open filling valves.
5. Start compressor by pushing the ON button.
6. When filling pressure gauge increases, open filling valves slowly.
7. Fill compressed air cylinders to the desired pressure, subsequently close filling valves slowly.
8. Close and vent all filling valves.
9. Disconnect all compressed air cylinders from filling valves.

AUTO START FUNCTION

Filling procedure automatic operation



Caution! Only fill cylinders which:

- are marked with the test mark and the test stamp of the expert.
- have been hydro static tested (check last test date).
- are rated for the final pressure.
- are free from humidity.



Note

The unit shuts down when final pressure is reached. Thus, the unit always has to be restarted manually.

1. Turn selector switch to automatic mode.
2. Close all filling valves.
3. Connect closed compressed air cylinders.
4. Open filling valves.
5. Start compressor by pushing the ON button.
6. When filling pressure gauge increases, open filling valves slowly.
7. Fill compressed air cylinders to the desired pressure, subsequently close filling valves slowly.
8. Close and vent all filling valves.
9. Disconnect all compressed air cylinders from filling valves.
10. If automatic operation is interrupted by:
 - pushing the OFF button
 - turning the selector switch
 - tripping the emergency shut-off switch
 - opening of the doors or the coverthe unit has to be restarted.

AUTO START FUNCTION

Ersatzteillisten

Best.-Nr. / Order No.	Benennung	Description
000203	Druckschalter	Pressure Switch
000783	HD-Abgangsverschraubung	HP-outlet connection
000794	T-Verschraubung	T-Piece
004691	Wahlschalter	Selector switch
005663	Einlegeschild	Label
006859	Schildträger	Label holder

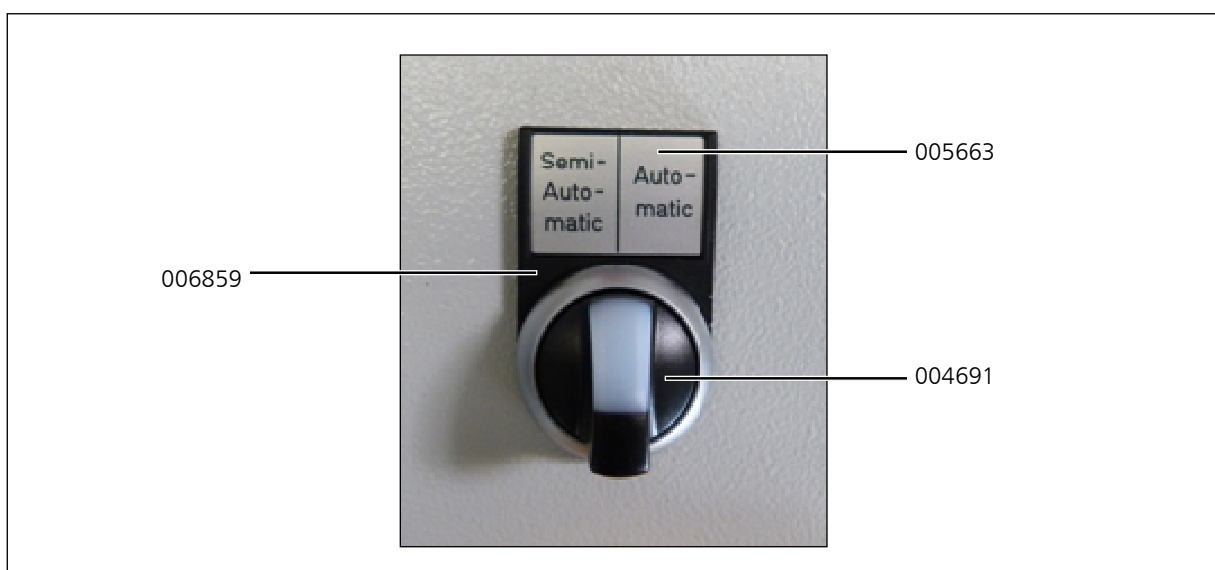
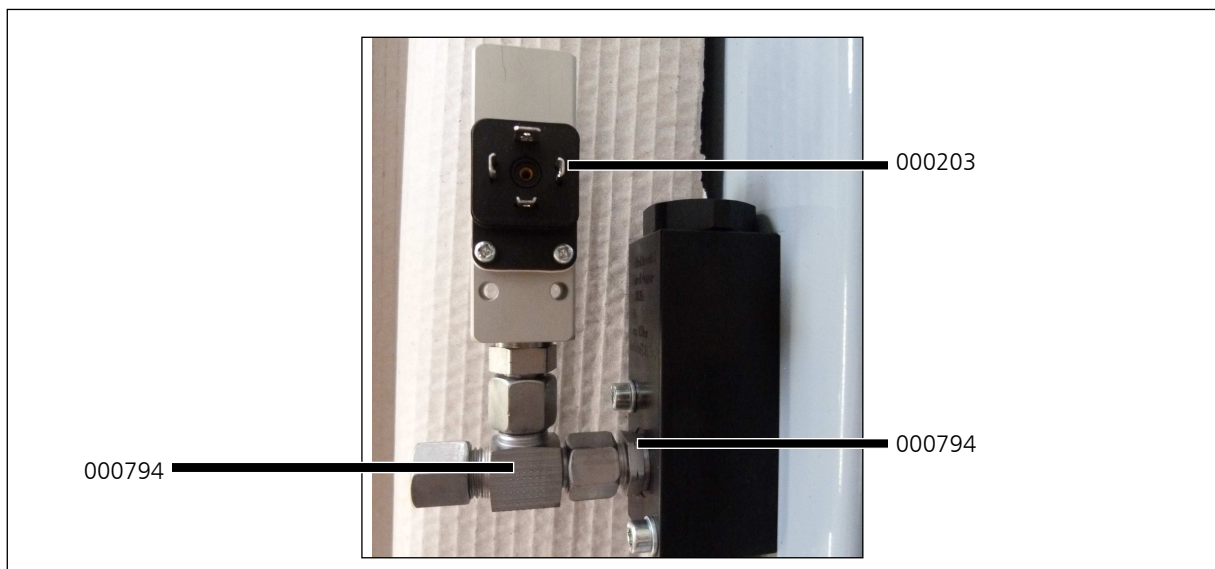



OIL TEMPERATURE MONITORING

D

OIL TEMPERATURE MONITORING

Oil temperature monitoring

Oil temperature monitoring

The oil temperature is maintained by a temperature sensor inside the compressor block during operation.

The compressor automatically shuts off when oil temperature exceeds the maximum pressure of +120 °C. The red warning lamp "Oil Temperature Monitoring" lights up.

Possible causes of fault:

- Ambient temperature too high
- Cooling air flow not sufficient
- Oil level too low
- Cooling pipes contaminated



Oil Temperature Monitoring



Warning

Risk of burns!

Allow the unit to cool before beginning troubleshooting.

OIL TEMPERATURE MONITORING

Spare part lists

Best.-Nr. / Order No.	Benennung	Description
004342	Display	Display
004730	Display und Sensor	Display and Sensor

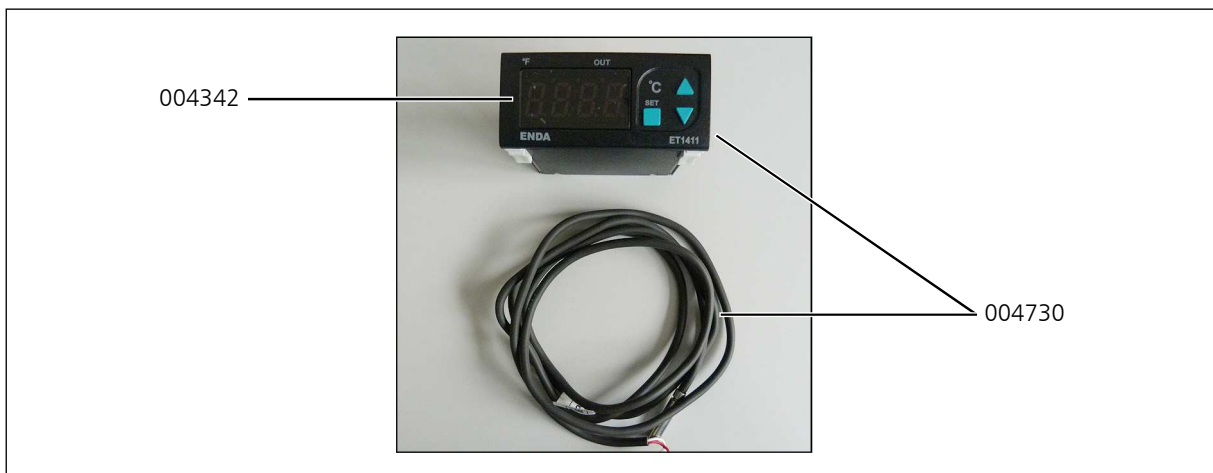

D



CYLINDER HEAD TEMPERATURE MONITORING

D

CYLINDER HEAD TEMPERATURE MONITORING

Cylinder head temperature monitoring

The cylinder head temperature is maintained by a temperature sensor at the cylinder head of the high pressure stage during operation. The compressor shuts off automatically when cylinder head temperature exceeds the maximum pressure of +160° C. The red warning lamp "Cylinder Head Temperature Monitoring" lights up.

Possible causes of fault:

- Ventilation of the compressor room is not sufficient
- Cooling air flow not sufficient
- Cooling pipes contaminated



Warning

Risk of burns!

Allow the unit to cool before beginning troubleshooting.

CYLINDER HEAD TEMPERATURE MONITORING

Spare part lists

Best.-Nr. / Order No.	Benennung	Description
004726	Display	Display
005585	Sensor	Sensor
008260	Zylinderkopf für Überwachung	Cylinder head for monitoring

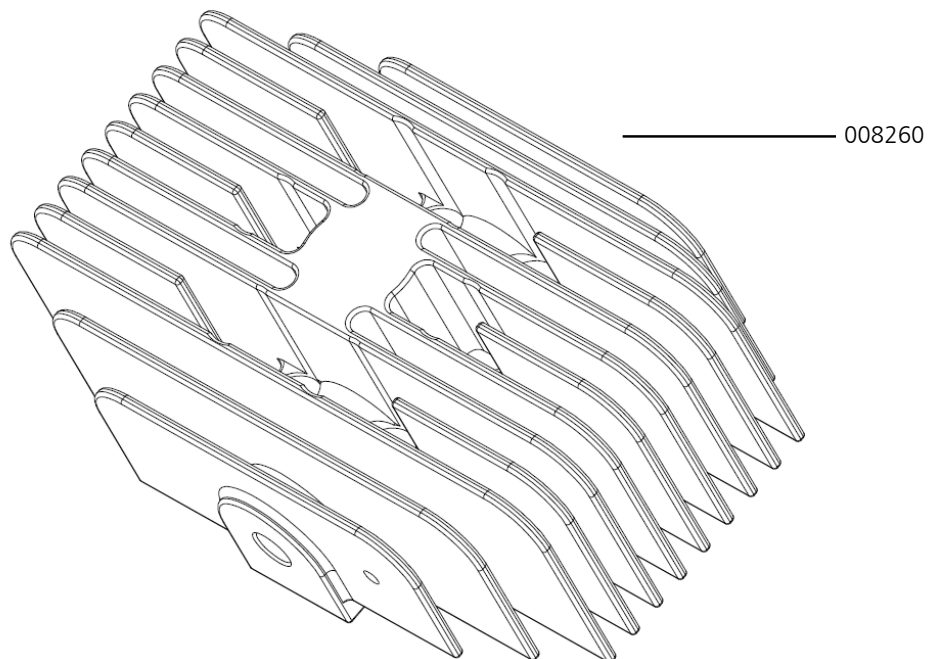
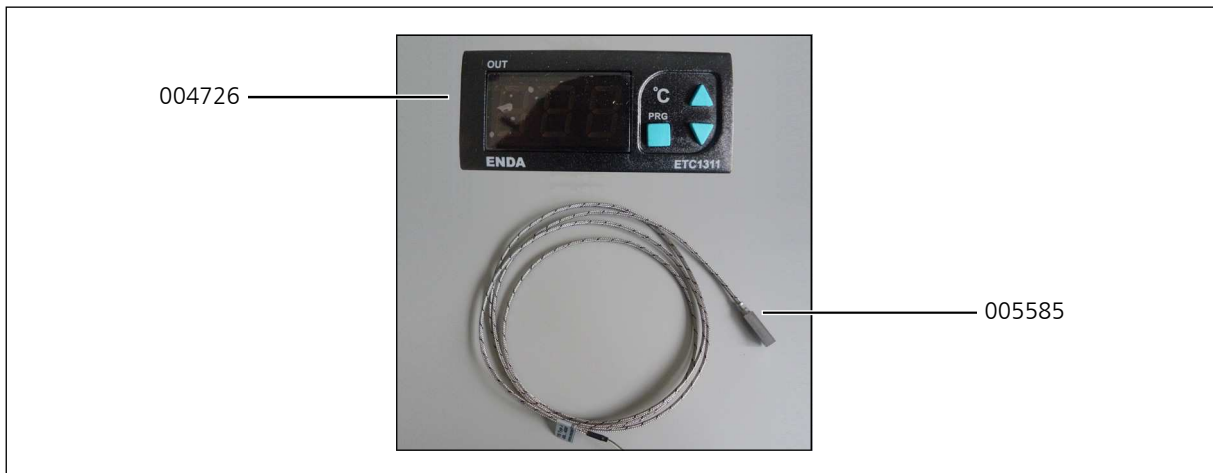



SPECIAL MACHINE FEETS

D

SPECIAL MACHINE FEETS

Special machine feets

L & W compressors can be also equipped with other machine feets alternatively.

The standard machine feets are height-adjustable. The version listed below can be used for floor mounting of the system.

The incorporated rubber (60 ° Shore A) compensates vibrations of the machine.



Alternatively machine feet

Note

Machine feets can be ordered individually. P/N: 000623

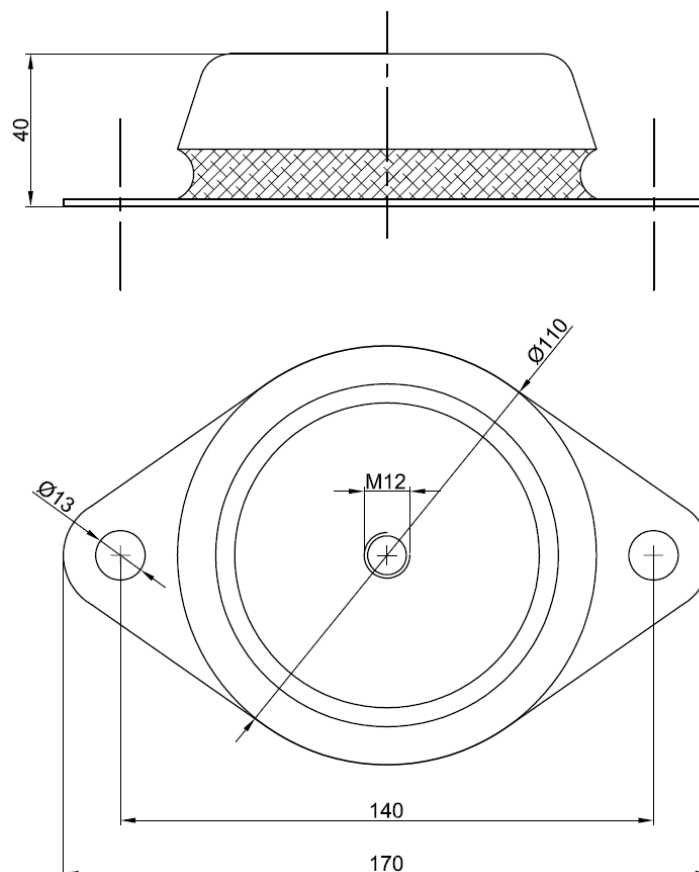



MAINTENANCE AND SERVICE 420 BAR VERSION

D

Service, Repair and Maintenance

Carry out service and maintenance work exclusively when the compressor is stopped and depressurised. The unit should be leak-checked regularly. Leaks can be preferably localised by using a leak detector spray (if necessary, brush pipes with soapy water).

We recommend that only authorised L&W service technicians carry out service work on the bearing of the compressor (crankshaft and connecting rods).

We urgently recommend that all maintenance, repair and installation work must only be carried out by trained personnel. This is necessary because all maintenance work can not be explained exactly and detailed in this manual.

Only use authentic spare parts for service work.



Danger

Components under pressure, such as hose ends, can quickly come loose when manipulated and can cause potentially fatal injuries due to the pressure surge. Any work on system parts may only be performed in a pressure-compensated state.



Warning

The use of accessories that have not been tested can lead to death or serious injury or damage to the unit. Only use authentic spare parts for service work.



Warning

Carry out maintenance or service work when the unit is switched off and protected against unexpected restart.



Warning

Risk of burns!

Carry out maintenance or service work when the unit has cooled down.



MAINTENANCE AND SERVICE

Daily before taking unit into operation

Maintenance work	Type	Quantity	Order No.
Check oil level	-	-	000001
Check condition of all filling hoses	-	-	-
Check filter cartridge lifetime	-	-	-
Operate unit to final pressure and check function of final pressure switch	-	-	-
Open manual drain valves of 2.3ltr filter housings	-	-	-

D

Every 3 months or as required

Maintenance work	Type	Quantity	Order No.
Check automatic condensate drain, open manual condensate taps	-	-	-
Check/Retorque all connections and bolts	-	-	-

Annually

Maintenance work	Type	Quantity	Order No.
Oil change, if less than 1000 operating hours	-	5.0	000001
Check opening pressure of final safety valve	-	-	-
Clean coolers	-	-	-
Clean all oil/water separators, if less than 500 operating hours	-	-	-
Service intake filter (depends on condition - if less than 500 operating hours)	-	-	-
Check all connections for leakage	-	-	-



MAINTENANCE AND SERVICE

Every 500 operating hours

Maintenance work	Type	Quantity	Order No.
Clean intake filter	-	1	002662
Check pressure maintaining/non-return valve	-	-	-

D



MAINTENANCE AND SERVICE

Every 1000 operating hours

Maintenance work	Type	Quantity	Order No.
Replace o-rings of intake filter housing	-	1	001316
Replace intake filter	-	1	002662
Replace sintered metal filter of oil/water separators	1st stage	1	002649
	2 / 3 stage	2	000173
	1 / 2 / 3 stage	3	002914
Replace o-rings of oil/water separators	1st stage	1	001306
	1st stage	2	001297
	2 / 3 stage	6	001272
Replace o-rings of oil/water separator	-	2	001294
Replace silencer	-	1	000178
Replace sintered metal filter of oil/water separators	-	2	000184
Replace sintered metal filter of pneumatic condensate valve	-	1	000188
Replace oil sieve and oil pump cover gasket	-	1	002569
Oil change	-	5.0	000001
Replace oil filter	-	1	003928
Replace o-rings of the final filter housing	-	8	001686
Replace back-up rings of the final filter housing	-	8	001687

D



MAINTENANCE AND SERVICE

Every 2000 operating hours

Maintenance work	Type	Quantity	Order No.
Replace all inlet and outlet valves incl. gaskets	1st stage	1	000936
	2nd stage	1	000259
	3rd stage	1	000551
	4th stage	1	000552
	Upper gasket 1st	1	002691
	Upper gasket 2nd	1	000257
	Lower gasket 1st	1	002690
	Lower gasket 2nd	1	002694

D

Every 4000 operating hours (Latest in 10 years)

Maintenance work	Type	Quantity	Order No.
Replace all o-rings and gaskets of 1st, 2nd, 3rd and 4th stage	gasket	4	002688
	o-ring	2	001296
Replace shaft seal	-	1	002714
Replace needle bearings for conrod 2nd, 3rd and 4th stage	-	6	002673

MAINTENANCE AND SERVICE

Service Kits

The service kits contain parts for maintenance according to the factory requirements.

The use of the service kits ensures that all required parts are ordered and replaced and gives assurance that all parts are included in the order. Depending on the model and interval, the service kits include parts such as O-Rings, Sinter Filter, Inlet Filter, V-Belts, Silencers, In-&Outlet Valve, Valve Seals and Compressor oil.



Service Kits

D

Service Kits LW 1300 E for 420 bar Versions

Compressor	Final Filter	Operating Hours	Order No.
LW 1300 E	1.7 l	1000 h	008254
LW 1300 E	1.7 l	2000 h	008255
LW 1300 E	1.7 l	4000 h	008256

MAINTENANCE AND SERVICE

Filter cartridge change

Filter cartridge change as follows:

- Run the compressor up to a pressure of 100 bar.
- Stop compressor.
- Open filling valve.
- Unscrew filter housing top by using the special filter tool (Fig. 1).
- Place the T-piece end of the filter tool in the recess of the filter cartridge (Fig. 2).
- Unscrew the filter cartridge anti-clockwise and pull the cartridge out of the housing (Fig. 3).
- Open the packing of the new filter cartridge and place it with the filter tool in the filter housing.
- Screw the new filter cartridge hand tight in by using the filter tool.
- Change the back-up ring and the o-ring of the top. (Correct change—see next page)
- Screw the cover of the filter housing first manually in.
- After it has been completely screwed in, turn top anticlockwise for 90°. This avoids tightening of the top due to vibration..

The filter cartridge change is now completed.



Note

Ensure that the old filter cartridge is disposed correctly at an approved waste point.



Fig. 1 - Unscrew the filter housing top.



Fig. 2 - Place the T-piece end of the filter key in the top of the filter cartridge.



Fig. 3 - Pull the cartridge out of the housing.

Filter housing - maintenance



Note

Clean all parts thoroughly before assembly.

Warm up the back-up ring to approx. 100 degrees C before installation.

Filter housing maintenance as follows:

- Open Filter top (Fig. 1).
- Change o-ring and prewarmed back-up ring, previously grease both (Fig. 2).
- Grease filter cover thread and close.

Dismount filter housing

- Loosen u-clamps and pipe connections and nuts (Fig. 3).
- Remove filter housing.
- Dismount filter housing base.
- Change o-ring and prewarmed back-up ring, previously grease both (Fig. 4).
- Screw filter base tight in.

Mount filter housing

- Connect pipe connections and tighten.
- Adjust u-clamps and tighten nuts.

The filter housing maintenance is now completed.



Fig. 1 - Open Filter top

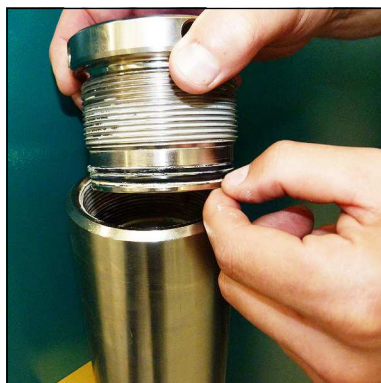

Fig. 2 - Change o-ring and back-up rings



Fig. 3 - Loosen u-clamps and pipe connections



Fig. 4 - Change o-ring and back-up rings

MAINTENANCE AND SERVICE

Change of cylinder gaskets



Note

Please do use silicone compound seal for cylinder gaskets. Do always grease the surface of the cylinder and the surface of the block.

It is necessary to make the surface free of grease perfectly. This is the first step to get it sealed. This is the most important step.

The best way to get it free of grease is to use ISOPROPANOL. Pure alcohol!

After this it is important to use the silicone compound seal. You will need to use it on the complete surface of the cylinder and the block. It is not enough to grease a thin layer. It must be applied liberally and cover the entire surface. Then you can use the gasket and can start to assemble the cylinder onto the block.

D

Cylinder heads

Stage	Tightening torque	Thread
1st Stage	85 Nm	M12
2nd Stage	55 Nm	M10
3rd Stage	30 Nm	M8
4th Stage	30 Nm	M8

Adapterplate for flywheel

Thread	Tightening torque	Grade
M12	140 Nm	12.9
M14	220 Nm	10.9

More standard torque for bolts

Description	Tightening torque	Thread	Grade
Flywheel	132 Nm	M14	8.8
Crankshaft counterweight	185 Nm	M14	10.9
Rubber coupling	350 Nm	-	-
Tension bolt connecting rod	25 Nm	M8	8.8



CONDENSATE TANK 60 LTR.

D

CONDENSATE TANK 60 LTR.

The 60 ltr. tank is equipped with an active carbon filter to collect condensate odourlessly and quietly. The condensate can be easily transported in the collecting tank and disposed environmentally sound.

The flexible connection hoses are fitted with quick-couplings, to allow easy separation from the compressor. The tank is equipped with a level gauge to indicate max. filling level. Two sturdy carrying handles ensure a safe transportation.

Technical Data:

- Dimensions: Ø 400 mm x 800 mm
- Weight: 20 kg



D

CONDENSATE TANK 60 LTR.

Maintenance and service

How to change the activated carbon and the metal filter insert

- Shut down the unit
- Plug out the condensate hoses
- Remove the protector cap, the nut and the allen bolts (Fig. 1)
- Take down the cover plate and the upper felt. Tip out the activated carbon and replace the lower felt
- Fill up the activated carbon and cover it with a new felt
- Put on the cover plate, screw the allen bolts and the nut and plug on the protector cap
- Unscrew the filter housing
- Remove the floater and the lower cover plate (Fig. 2)
- Take a pliers and pull the metal filter out of the metal case
- Insert the metal filter
- Install the cover plate and the floater
- Screw the filter housing onto the tank
- Plug in the condensate hoses

Maintenance intervals

We recommend to change the activated carbon if it has reached the saturation level (smell of oil).

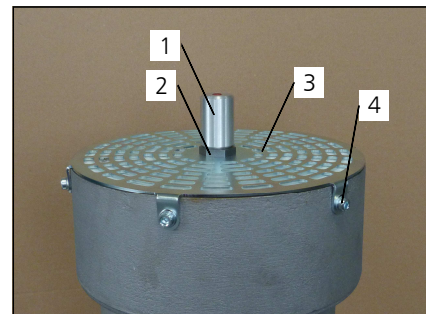

Fig. 1

- 1 Protector cap
- 2 Nut
- 3 Cover plate
- 4 Allen bolts (6x)

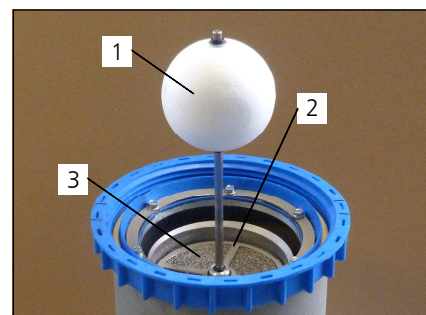

Fig. 2

- 1 Floater
- 2 Lower cover plate
- 3 Metal filter

CONDENSATE TANK 60 LTR.

Spare part lists

Best.-Nr. / Order No.	Benennung	Description
003091	Kondensatbehälter 60 Liter	Condensate Tank 60L
004056	Kondensatschläuche Kondensatbehälter 60L, für 3-	Set of condensate hoses, 3 stages
004057	Kondensatschläuche Kondensatbehälter 60L, für 4-	Set of condensate hoses, 4 stages

D

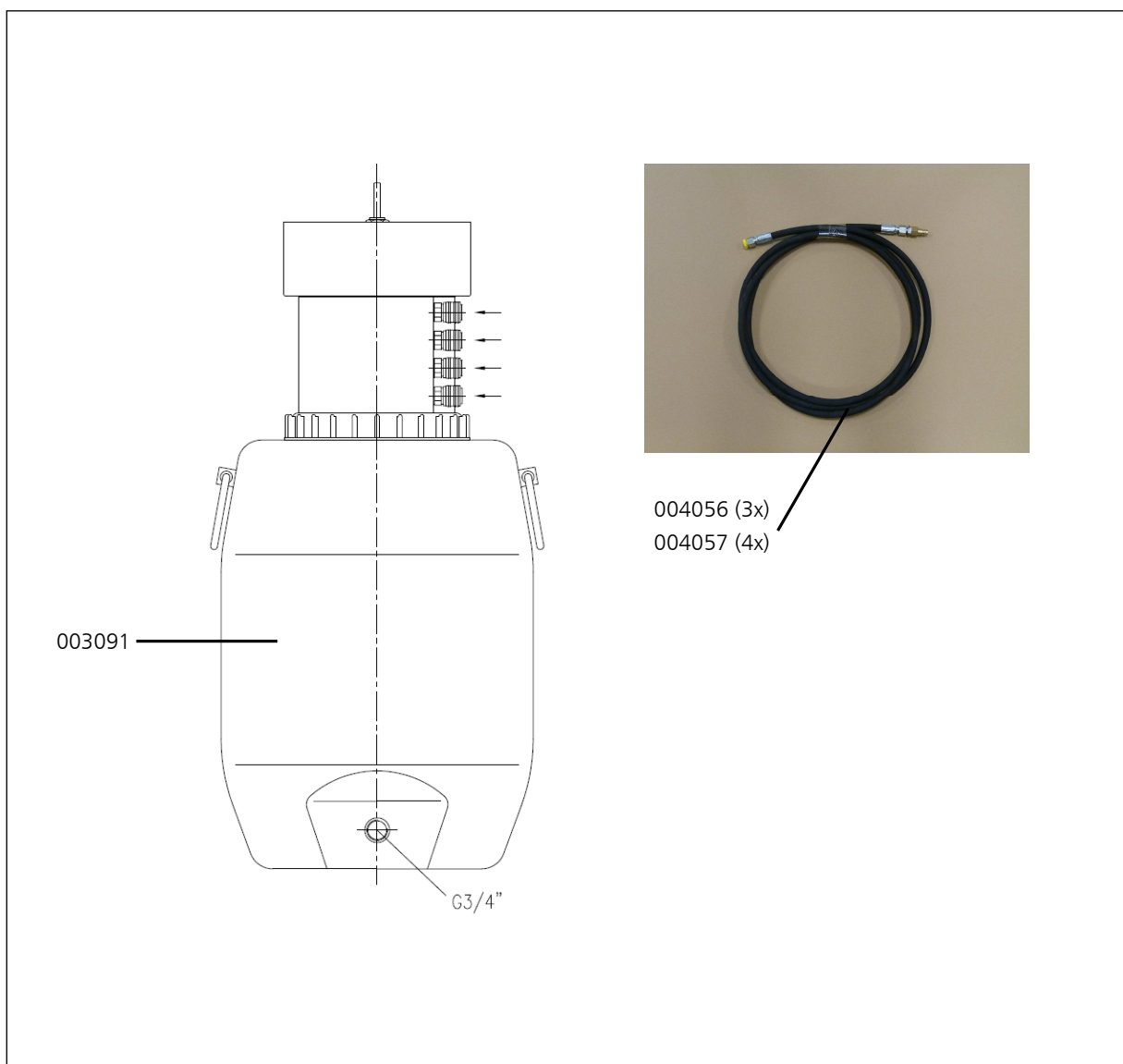

CONDENSATE TANK 60 LTR.

Spare part lists

Best.-Nr. / Order No.	Benennung	Description
000508	USIT-Ring 13,7 x Ø20 x 1,5	Gasket Ring U-Sit 13,7 x Ø20 x 1,5
003866	Filter Nachfüllset für 60 Liter	Filter refill set 60 ltr
004789	Schnellkupplung G1/4", DN 7,2	Quick connector G1/4", DN 7,2
006642	Metallgestrick für Kondensatbehälter 60 ltr	Metal filter insert 60 ltr tank

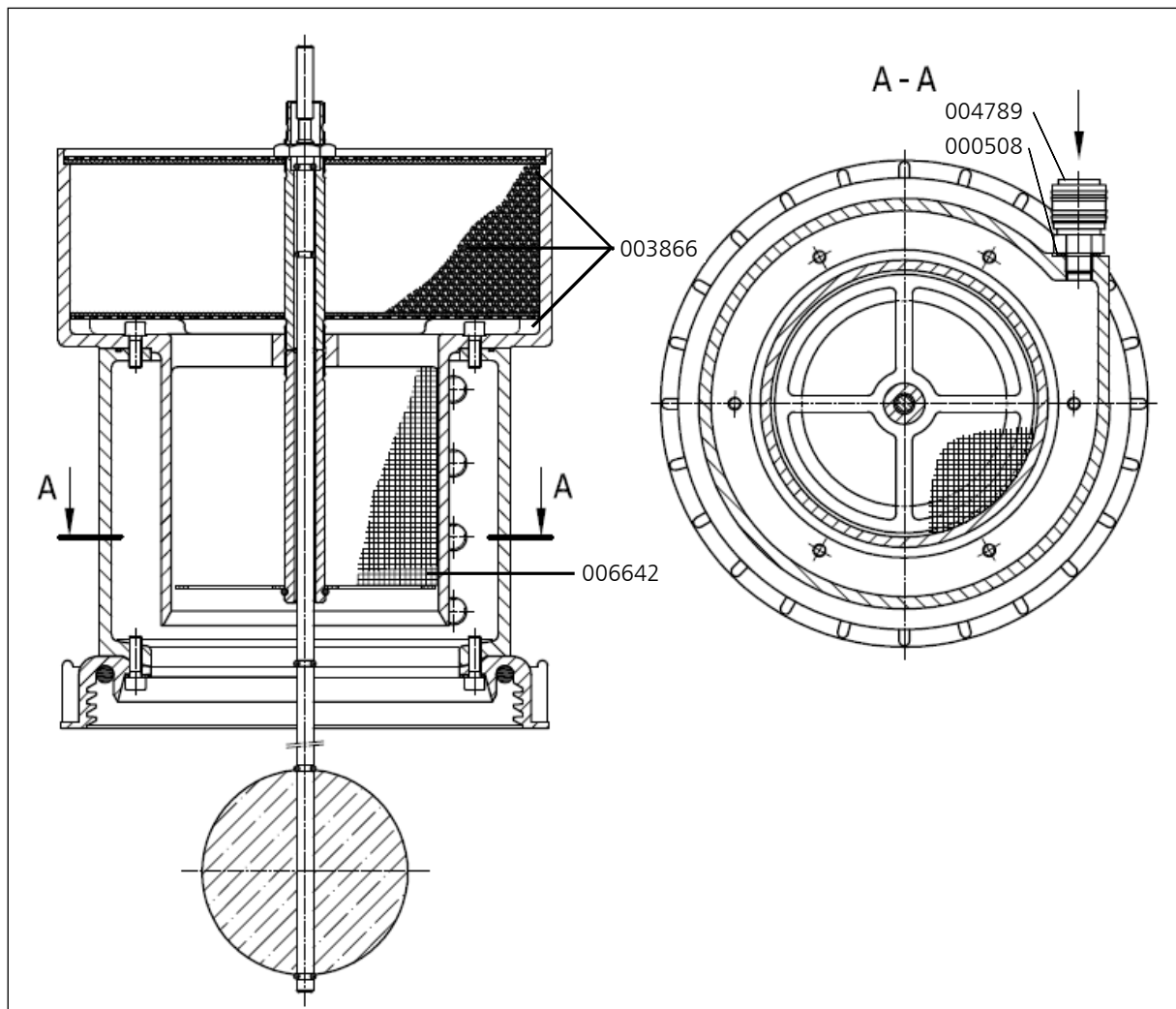

D



ATTACHMENT

E

Lenhardt & Wagner GmbH

**An der Tuchbleiche 39
D-68623 Lampertheim – Hüttenfeld**

www.lw-compressors.com



Operating Instruction

Safety valve

Typ:

SiV2 BKZ 989 TÜV.SV.12-989.5.G.V.P CE 0091 AlMgSi1 F31 1100* Lenhardt & Wagner

SiV BKZ TÜV.SV.14-1140.5.G.V.p CE 0091 AlMgSi1 F31 1100* Lenhardt & Wagner

Set pressure:	see mark (hand wheel on top of valve)
Maximum outflow:	Set pressure 100-159 bar: 750 l / min Set pressure 160-350 bar: 1.100 l / min
Suitable media:	Media-resistant, non-corrosive gases

The safety valve is used for protection of pressurized components, eg pipelines, pressure vessels, or the compressor itself.

The hand wheel on the top of the safety valve is marked with the adjusted set pressure.



- 1) **Identification of set pressure**
- 2) **Seal**
- 3) **Fixing screws¹**
- 4) **Venting screw (hand wheel)**
- 5) **Identification serial number**
- 6) **Socket for safety valve**

Safety valve with socket

¹ und die Anforderungen des AD 2000 Merkblatts W7 erfüllen. Schaftlänge 70mm. The fixing screws M8 must be strength class 8.8 and meet the requirements of Merkblatt AD 2000 leaflet W7. Shaft length 70mm.

In order to prevent manipulation of the set pressure, all safety valves are factory fitted with a seal.

A safety valve on which the seal has been removed, must be returned before further use to the manufacturer for repair / adjustment.

In addition, the safety valve has a venting device (hand wheel).

In the rotation direction clockwise, the safety valve and herewith also the filter housing of the final stage could be completely vented.

During normal operation, the screw is unscrewed to the upper stop anticlockwise, an integrated safety ring prevents that the screw can be completely unscrewed.

If a safety valve blow off, the system must be switched off immediately and investigate the cause of the error.

There are two possible reasons:

1. The safety valve is defective and blows off before the set pressure.

In this case the safety valve should be submitted immediately to the manufacturer for repair or replaced with a new one.

2. The safety valve opens properly, the problem is on the system.

A constant blowing of the safety valve is not permitted, the sealing seat of the valve can be damaged. The error on the system must be detected and repaired before further filling operations.

The safety valve may only be used if it is ensured that the maximum flowrate of the system does not exceed the blowoff rate of the safety valve.

The safety valve may only be used with the approved media.

Repair work on compressors must only be performed by trained personnel.

Dismantling of the safety valve

Ensure that on the safety valve is no pressure.

Loosen and remove the two M8 fixing bolts with a 6mm Allen key.

The safety valve can now be removed by turning and simultaneously pulling out of the socket.

Mounting

1. Clean the safety valve socket.

2. Oil the insert pin of the safety valve including the O-ring with 1 to 2 drops of oil.

3. Press the safety valve pin complete into the socket.

4. Fasten the safety valve with the two 8 mm allen screws into the socket

(Tightening torque: 10 Nm)

5. Screw the venting screw (hand wheel) anticlockwise to its upper limit.

6. Start the System (Compressor), check installation for leaks and proper function.

Manufacturer: Lenhardt & Wagner GmbH
An der Tuchbleiche 39
D-68623 Lampertheim – Hüttenfeld

Kontakt: E-Mail: service@lw-compressors.com
Web: www.lw-compressors.com
Tel.: +49 (0) 6256 – 85880 0
Fax: +49 (0) 6256 – 85880 14

Note:

*Use the safety valve only in a technically perfect condition, for its intended purpose, safety and danger awareness, in compliance with the operating instructions!
Especially disorders which could affect safety must be remedied immediately!*

Notes:

- The safety valve must be installed directly on the protected pressure vessel and / or the plant.
 - The safety valve must be installed in an upright position.
 - The flow area of the port must be greater than the valve opening.
 - Protect valve against splashes
-

Maintenance:

- The safety valve is periodically - in accordance with the currently valid Pressure Equipment Directives - to check on operation and reliability.
- Refill annually lubricating oil:
Oil filling position:
Hole on the spacer (see arrow, Figure 1)
- Oil level: Fill oil into the hole until oil comes out of the hole.

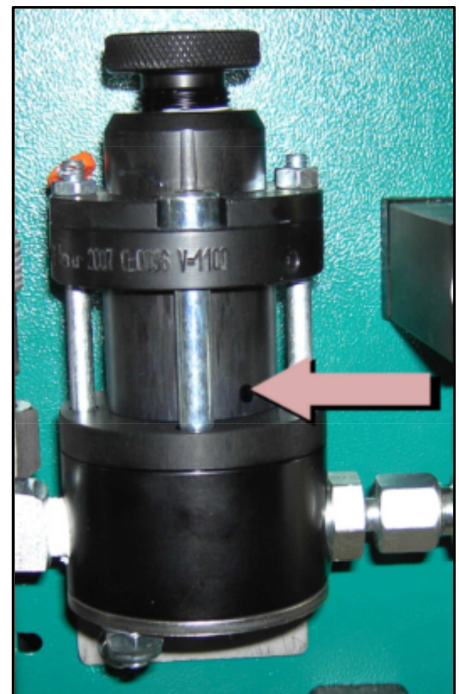

Figure 1: Position for oil refill

To be used lubricating oil for the safety valve: L&W Article Nr.: 008500 (content: 30 ml)
